

當醫檢碰上晶片

-醫檢晶片化-

1

林亮音

台大醫學院醫學檢驗暨生物技術學系

The term-projects of students include

2

- Development of Quantum Dot microreactor & detection platform 工業用量子點材料微反應器與檢測平台開發(史唯里、戴勤、陳品帆)、(江淑菁)
- Smart Contact lens for monitoring chronic diseases 智慧型醫用隱形眼鏡系統開發(吳伊敏、鄭珮好、廖證傑)
- High performance Western Blotting Integration System 高效西方墨點法檢測平台開發(黃偉祐、林祐賢、康惟誠)
- New enzyme-linked immunosorbent assay (ELISA) system 全新高效酵素免疫分析系統(江佳瑛、黃昱豪、吳宗翰)、(江淑菁)

血液學 – 紅血球、白血球、血小板

3

	Male	Female
Hemoglobin (g/dL)	13.5-17.5	11.5-15.5
Hematocrit (PCV, HCT) (%)	40-52	38-48
Red cell count ($10^{12}/L$)	4.5-6.5	3.9-5.6
Mean cell hemoglobin (MCH) (pg)	27-34	
Mean cell volume (MCV) (fL)	80-95	
Mean cell hemoglobin concentration (g/dL)	30-35	
Reticulocyte count ($\times 10^9/L$)	50-150	

From: Essential Haematology 6th eds. 2011

➤ 期待解決的問題

➤ 如何用微流體晶片檢測血比容(hematocrit)?

General principles of blood cell counting



A. Electronic impedance principle

- **Electric impedance principle:** Coulter principle
 - low-voltage direct current (DC)
 - High frequency radio frequency (RF)

B. Optical detection principle

- Dark-field optical by non-laser light
- **Laser optic principle**

Electric impedance principle

(電子阻抗原理)

5

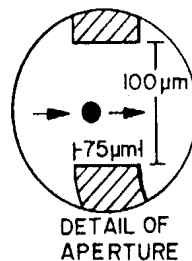
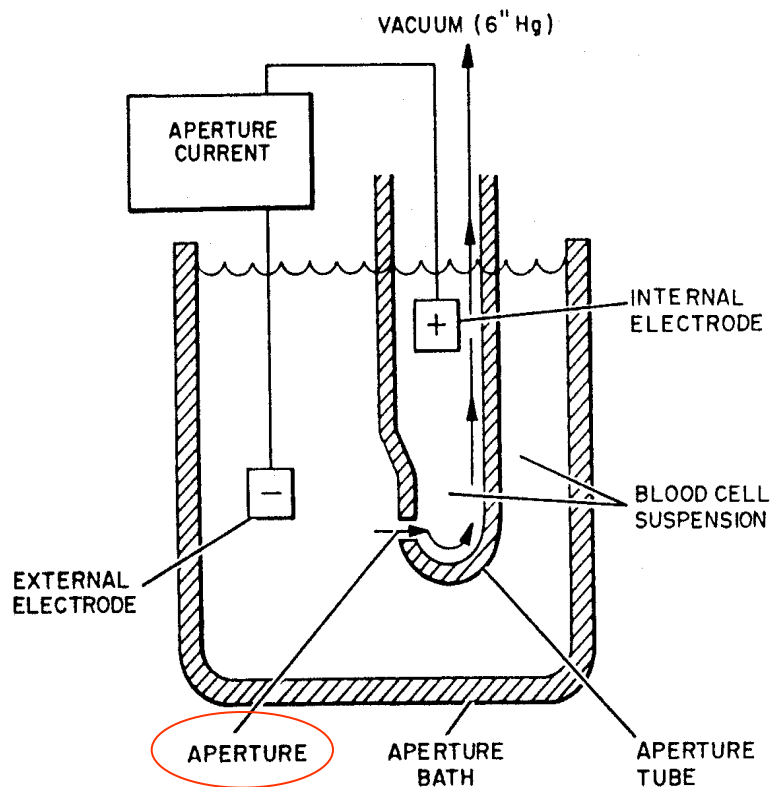

血球細胞係電流不良
導體, 通過直流電電
場*即產生電阻

Impedance (電阻)
= $k \times \text{volume}$ (體積)

* Low-voltage direct current

Radiofrequency

(高頻電磁波)

測定細胞核的大小及密度

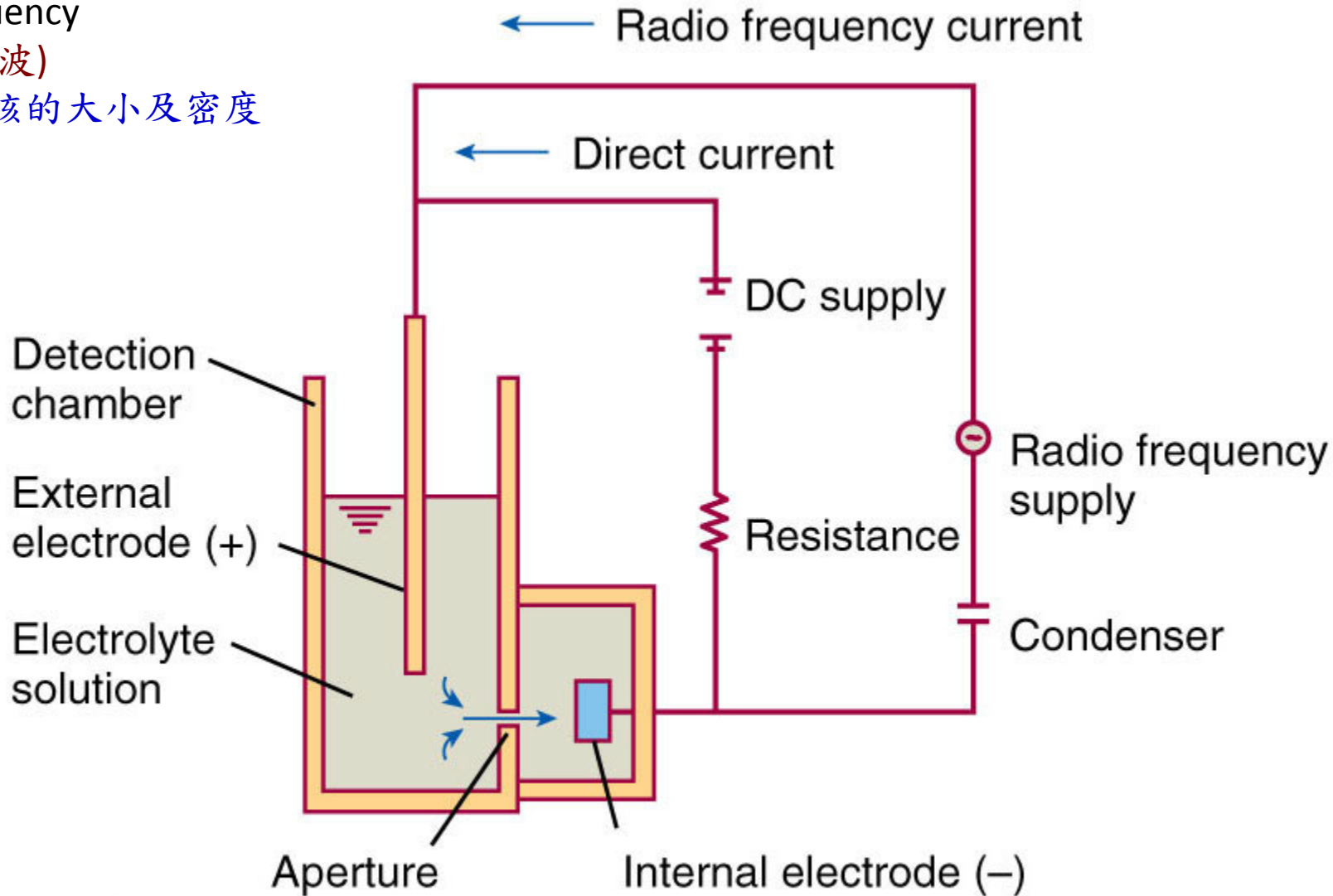

(From Toa Medical Electronics Co., Ltd.: Sysmex SE-9500 Operator's Manual [CN 461-2464-2]. Kobe, Japan: Toa Medical Electronics Co., Ltd., 1997.)

Fig. 39-3. RF/DC detection method, showing simultaneous use of DC and RF in one measurement system on the Sysmex SE-9500.

DIFF Channel (Sysmex SE-9000)

DC (Direct Current):

測定血球體積的大小 (Impedance)

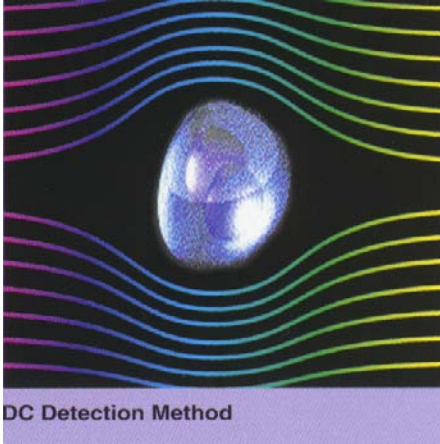

RF (Radio Frequency):

測定細胞核的大小及密度

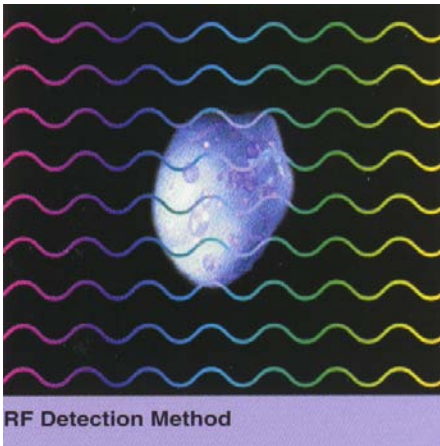

RF

Granulocyte



Lymphocyte

Monocyte

DC

Total WBC

Optical detection principle

1. dark-field optical (light scattering)

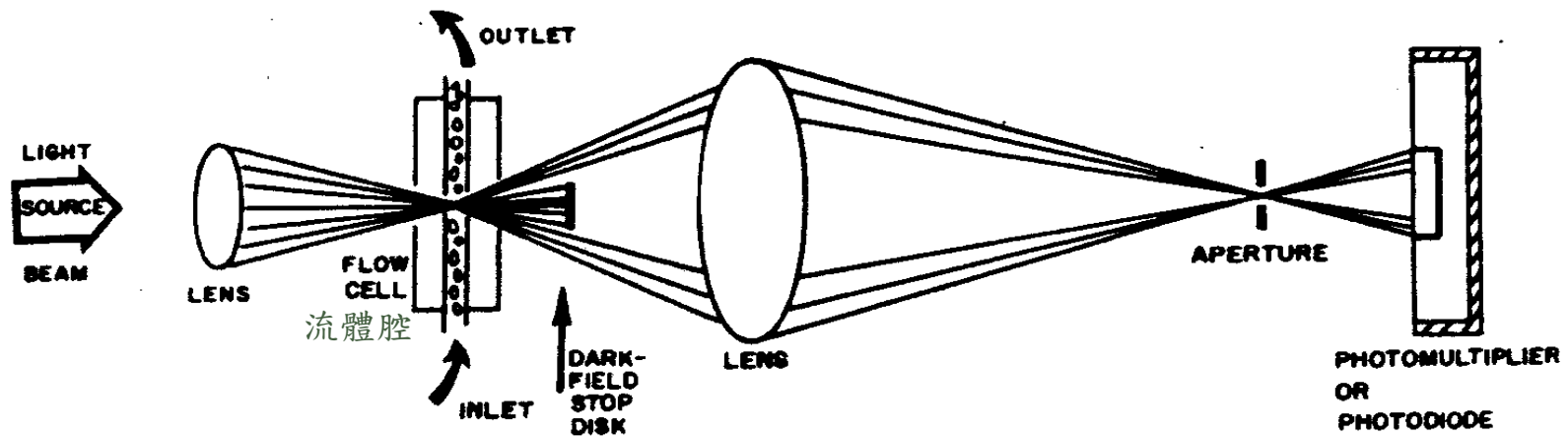

Fig. 169. Optical principle of cell counting. (Wintrobe, *Clinical Hematology*, 8th ed. Lea & Febiger.)

Light source: halogen lamp (鹵素燈)

Detect cell passage → light scatter event (cell count)

Optical detection principle

2. Laser optical principle (narrow beam diffraction)

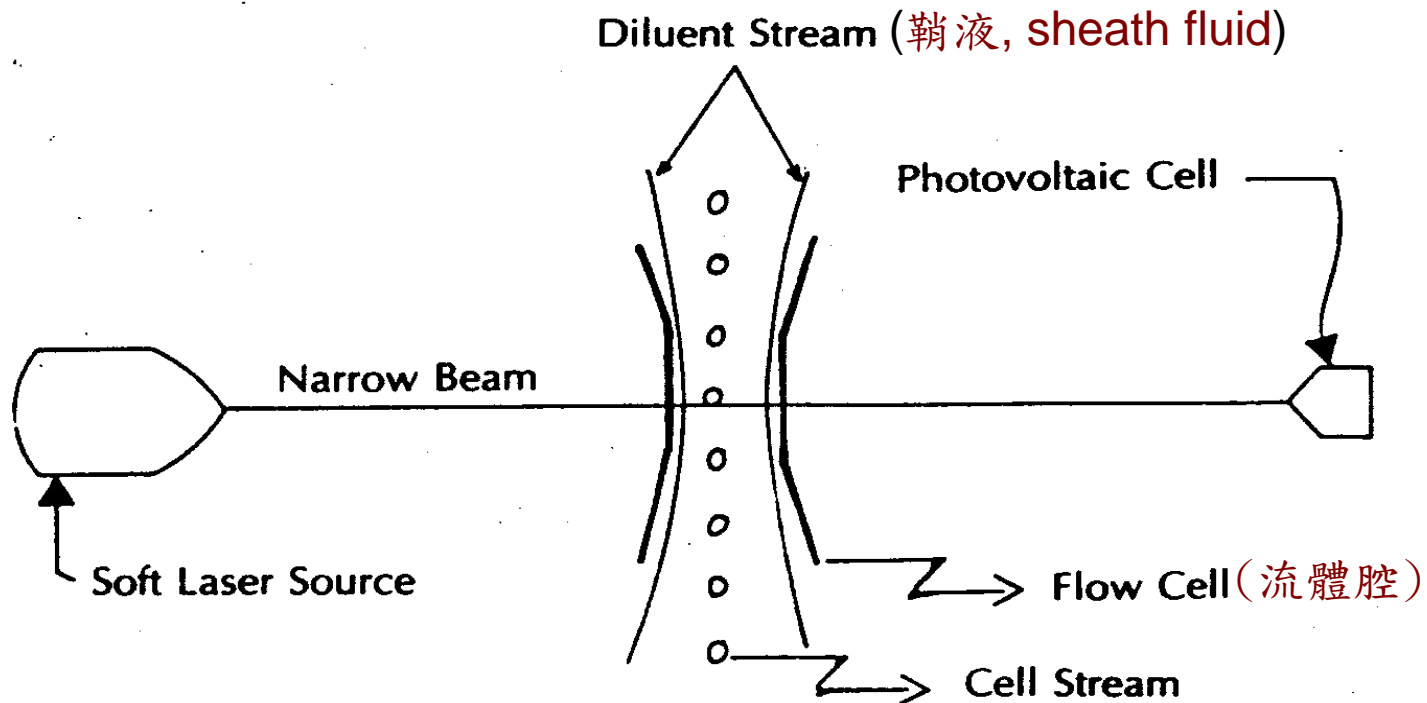

Light source: monochromatic, high energy **laser beam**

Cell passage → light scatter event (cell count)

Forward scatter → cell size, 90° side scatter → nuclear complexity/ granularity

In summary



Measurement cell (particle) number and size :

- Electric impedance principle
- Laser optical principle

Detecting the internal features of the cells

- High frequency radio wave
- Laser optical principle

Hemoglobin (血色素) determination

11

- Cyanmethemoglobin (Hemoglobinocyanide) method
- Diluted in a solution of potassium ferricyanide and potassium cyanide

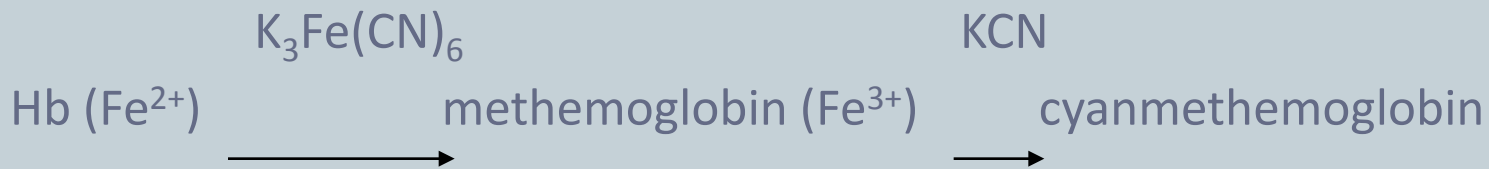

- Read the absorbance of the cyanmethemoglobin at 540nm
- With cyanmethemoglobin standard and accompanied with standard curve

Hb detection in automated blood cell counter ---colorimetric methods



1. Cyanmethemoglobin method (ICSH standard method)



2. SLS-Hb method Hb 氧化 : Hb Fe(2+) \rightarrow MetHb Fe(3+) SLS + MetHb Fe(3+) \rightarrow SLS-MetHb

Absorbance at 540nm

ICSH: International Committee of Standardization in Hematology

SLS: sodium lauryl sulfate, sodium dodecyl sulfate, anionic surfactant

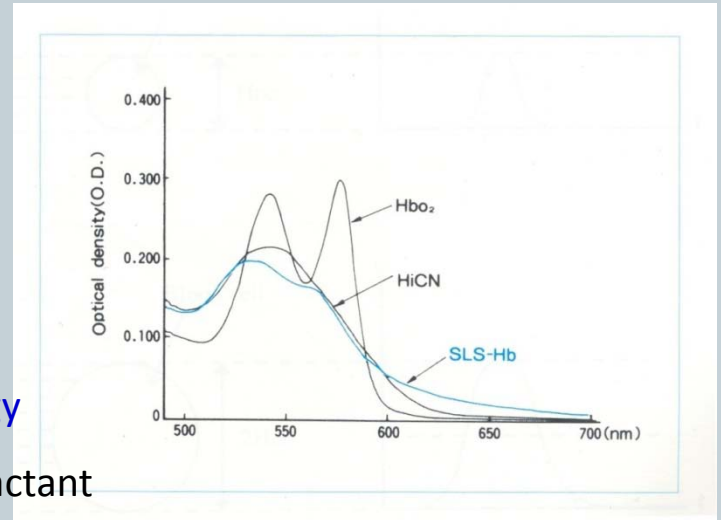

SLS-Hb 優點



- SLS (Sodium Lauryl Sulfate) : detergent & anionic surfactant
- Cyanide-free reagent: 無生物毒性
- 與標準氰化物法相關性高 ($R^2=0.999$)

Hematocrit (Hct, 血比容) and microhematocrit

- The volume of packed RBCs in the volume of whole blood
- Packed cell volume (PCV)
- Hematocrit (Wintrobe tube): 3000rpm, 30mins
 - macrohematocrit
- Microhematocrit (capillary tube): 10,000-15,000g, 10mins
- Microhematocrit reader

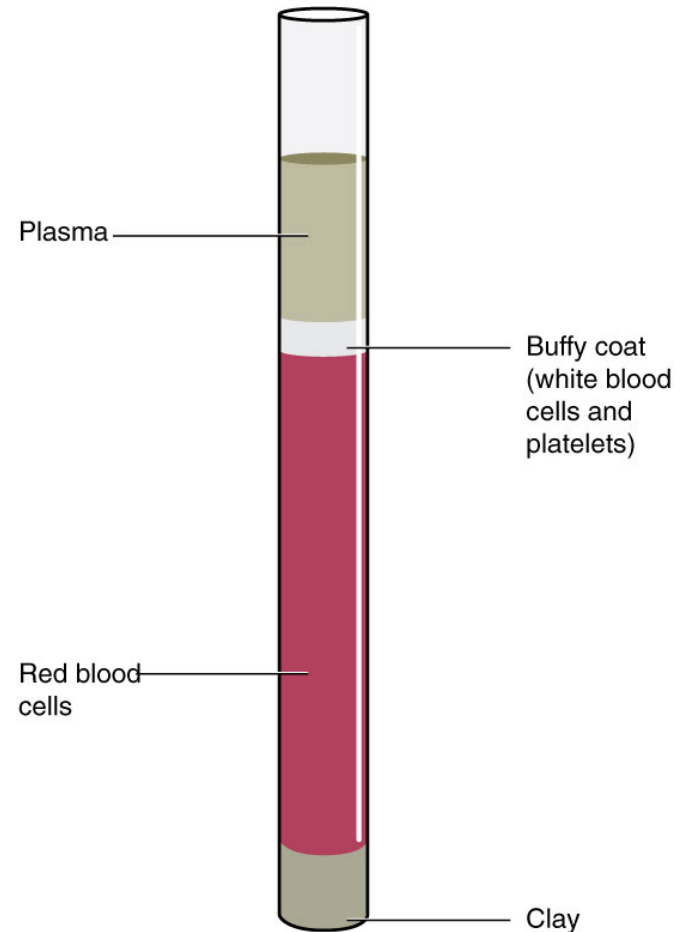

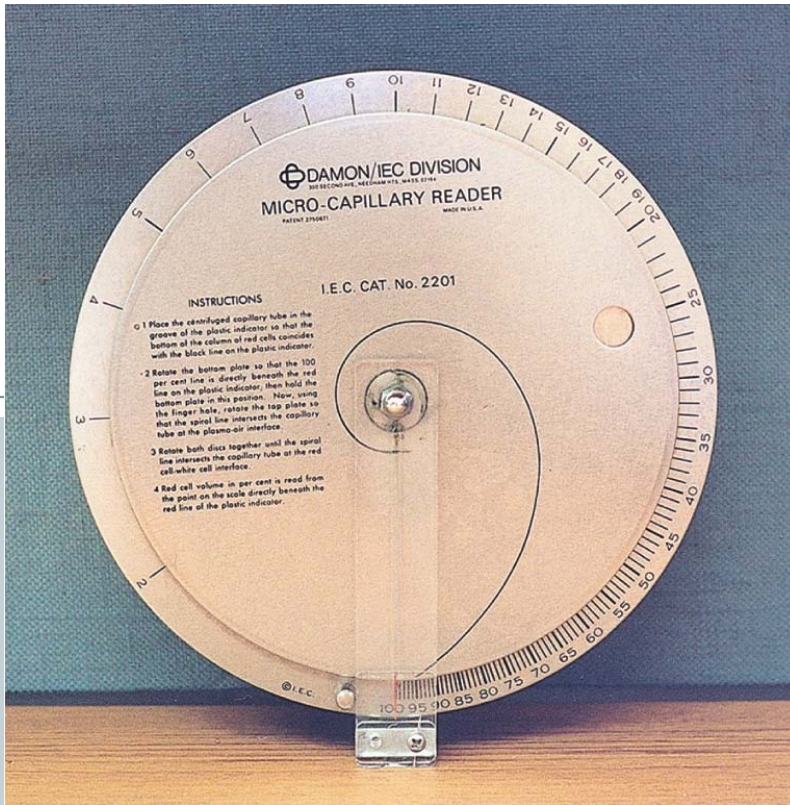

Microhematocrit reader

15



READACRIT centrifuge with built-in capillary tube compartments and Hct scales

Hematocrit (Hct) determination

iSTAT-1[®] POCT device

16

- The iSTAT-1 POCT device (Model iSTAT-1 with EC6+ cartridges, I-STAT Corp., Princeton, NJ) uses a conductivity-based method to measure blood hematocrit.
- Briefly, whole blood is introduced by capillary action into a single-use microfabricated biosensor cartridge. After correction for electrolyte concentration, the measured conductivity is inversely related to the blood hematocrit.
- Blood hemoglobin concentration is calculated by the following equation: $\text{hemoglobin (g/dl)} = \text{hematocrit (\%)} \times 34$

Hematocrit (Hct) determination

iSTAT-1[®] POCT device

17

- Each i-STAT cartridge contains one reference electrode (when potentiometric sensors are included in the cartridge configuration), sensors for the measurement of specific analytes, and a buffered aqueous calibrant solution of known conductance that contains known concentrations of analytes and preservatives.

Hematocrit (Hct) determination iSTAT-1[®] POCT device

18



HemoPoint[®] H2 Hemoglobin Meter

19



**Two results
with one test**

HemoPoint[®] H2 Hemoglobin Meter

20

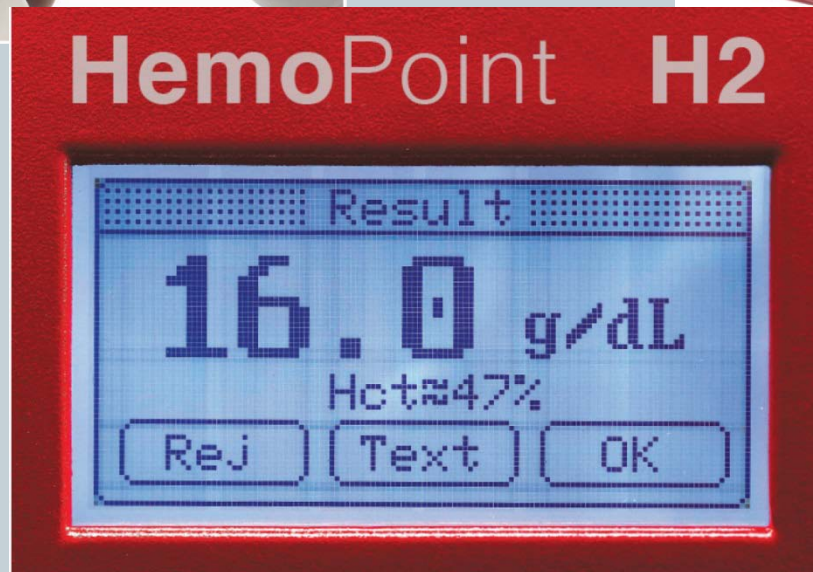

HemoPoint[®] H2 Hemoglobin Meter

21

- The Alere HemoPoint[®] H2 System is intended for the quantitative determination of hemoglobin (Hgb) in whole blood of adults, infants, and children in a professional point-of-care setting. It consists of a dedicated meter and individual, single-use Alere HemoPoint[®] H2 Microcuvettes filled with reagents.
- The hematocrit value will be calculated using the formula $Hct (\%) = F \times Hgb [g/dL]$, with $F = 2.94$. A true hematocrit test is not determined with this system.
- The use of this formula is allowed only within the normal hemoglobin range, means from 12.0 g/dL (7.44 mmol/L) – 18.0 g/dL (11.16 mmol/L). If the Hgb result is outside this range then the estimated hematocrit result will not be calculated and “N/A” will appear

血液學 – 紅血球、白血球、血小板

22

	Male	Female
Hemoglobin (g/dL)	13.5-17.5	11.5-15.5
Hematocrit (PCV, HCT) (%)	40-52	38-48
Red cell count ($10^{12}/L$)	4.5-6.5	3.9-5.6
Mean cell hemoglobin (MCH) (pg)	27-34	
Mean cell volume (MCV) (fL)	80-95	
Mean cell hemoglobin concentration (g/dL)	30-35	
Reticulocyte count ($\times 10^9/L$)	50-150	

From: Essential Haematology 6th eds. 2011

➤ 期待解決的問題

➤ 如何用微流體晶片檢測血比容(hematocrit)?

紅血球 – 貧血

23

- 貧血的分類與傳統檢驗
- 血液檢驗報告的認識
- 期待解決的問題
 - 如何用微流體晶片檢測球狀紅血球增多症(hereditary spherocytosis)

Table 2.5 Classification of anaemia.

Microcytic, hypochromic	Normocytic, normochromic	Macrocytic
MCV <80 fL	MCV 80–95 fL	MCV >95 fL
MCH <27 pg	MCH ≥27 pg	Megaloblastic: vitamin B ₁₂ or folate deficiency Non-megaloblastic: alcohol, liver disease, myelodysplasia, aplastic anaemia, etc. (see Table 5.10)
Iron deficiency	Many haemolytic anaemias	
Thalassaemia Anaemia of chronic disease (some cases) Lead poisoning Sideroblastic anaemia (some cases)	Anaemia of chronic disease (some cases)	
	After acute blood loss	
	Renal disease	
	Mixed deficiencies	
	Bone marrow failure (e.g. post-chemotherapy, infiltration by carcinoma, etc.)	

MCH, mean corpuscular haemoglobin; MCV, mean corpuscular volume.

Classification of hemolytic anemias

25

Hereditary

Membrane

Hereditary spherocytosis

Hereditary elliptocytosis

Metabolism

G6PD deficiency

Pyruvate kinase deficiency

Hemoglobin

Genetic abnormalities

Acquired

Immune

Autoimmune

Alloimmune

Drug associated

Red cell fragmentation syndromes

Secondary

liver and renal disease

Infections (malaria, clostridia)

Chemical and physical agents

March hemoglobinuria

Paroxysmal nocturnal hemoglobinuria

Membrane defects

26

- Hereditary spherocytosis
- Hereditary elliptocytosis
- South-East Asian ovalocytosis

Hereditary spherocytosis (HS)

27

- HS is usually caused by defects in the proteins involved in the vertical interactions (band 3-ankyrin-spectrin-protein 4.2) between the membrane skeleton and the lipid bilayer of the RBC.
 - Ankyrin deficiency or abnormalities
 - α - or β -spectrin deficiency or abnormalities
 - Band 3 abnormalities
 - Pallidin (protein 4.2) abnormalities

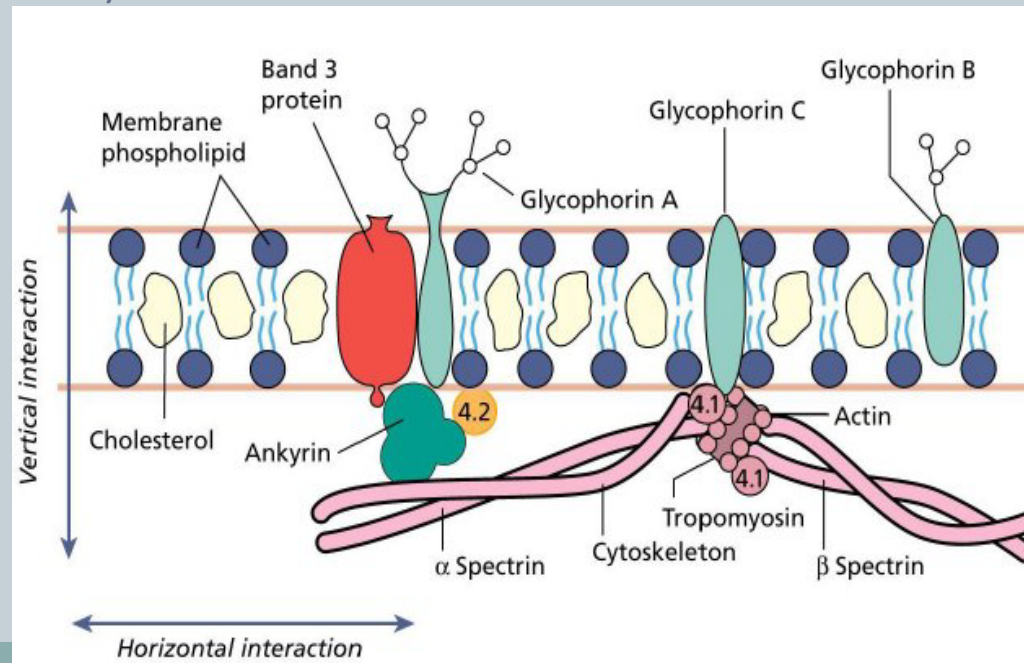

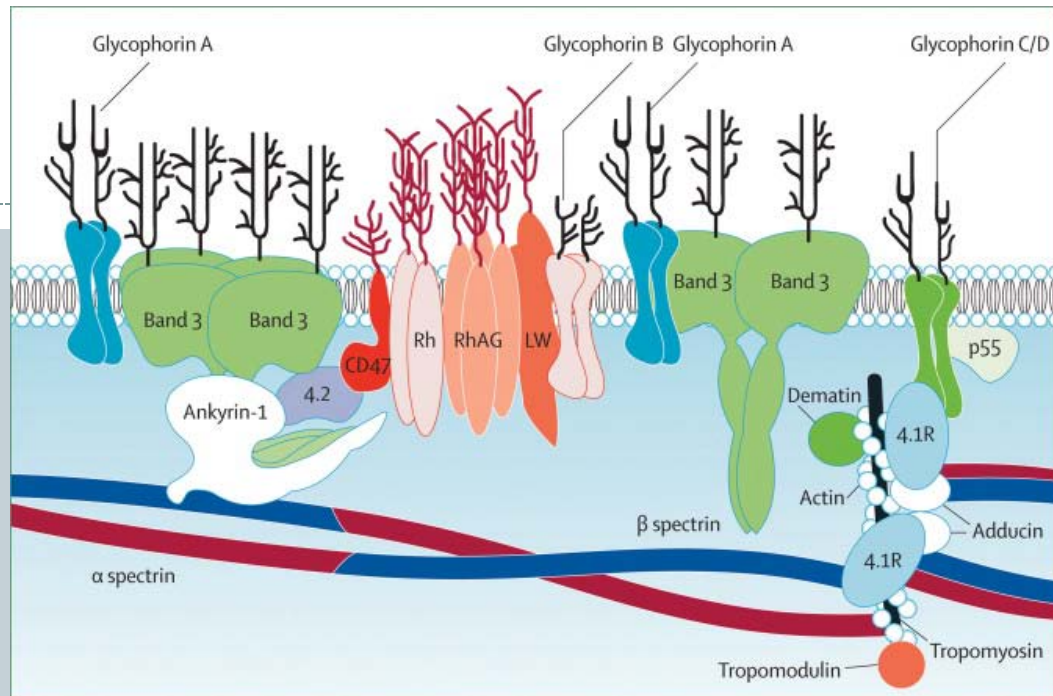

	Patients with HS	Heredity	Prevalent mutations	Protein reduction	Disease severity	Peripheral blood smear
Ankyrin-1	USA and Europe 40–65%; Japan 5–10%	AD, AR, de novo	AD or de novo: null mutation; AR: mis-sense and promoter mutations	Spectrin and ankyrin-1 15–50%	Mild to moderate	Spherocytes
Band 3	20–35%	AD	Functionally null mutation	Band 3 15–35%	Mild to moderate	Spherocytes, occasional mushroom-shaped or pincered cells
α spectrin	<5%	AR	α-LEPRA allele and null mutation	α spectrin 50–75%	Severe	Spherocytes, contracted cells, and poikilocytes
β spectrin	15–30%	AD, de novo	Null mutation	β spectrin 15–40%	Mild to moderate	Spherocytes, 5–10% acanthocytes
Protein 4.2	USA and Europe <5%; Japan 45–50%	AR	Mis-sense (prevalence of 4.2 Nippon)	Protein 4.2 95–100%	Mild to moderate	Spherocytes, ovalostomatocytes

AD=autosomal dominant. AR=autosomal recessive. HD=hereditary spherocytosis. LEPRA=low-expression allele Prague.

Table 2: Clinical and molecular characterisation of hereditary spherocytosis molecular defects

Hereditary spherocytosis (HS)

29

Clinical feature:

- Autosomal dominant with variable expression; rarely autosomal recessive
- The anemia can present any age from infancy to old age
- Jaundice
- Splenomegaly
- Pigment gallstones
- Aplastic crises: parvovirus B19

Osmotic fragility test

30

- To measure the ability of the red cells to take up fluid without lysing
- Factors involved or affecting of
 - The shape of RBCs – volume, surface area and functional state of RBC membrane
 - Concentration of saline solution

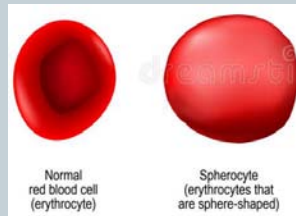
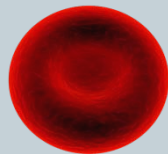
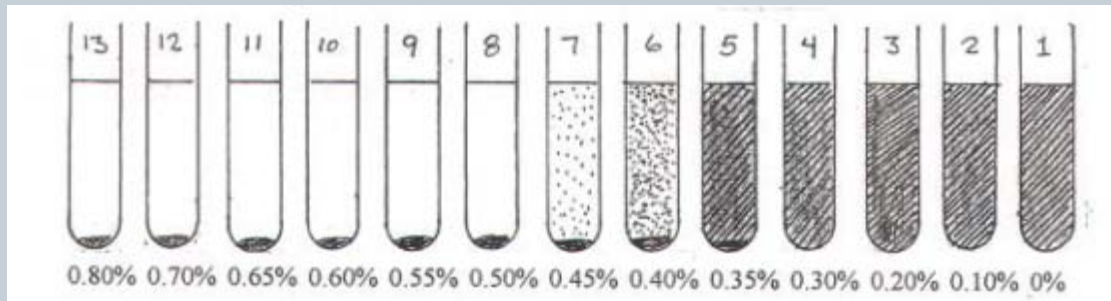

Normal red blood cell (erythrocyte) Spherocyte (erythrocytes that are sphere-shaped)

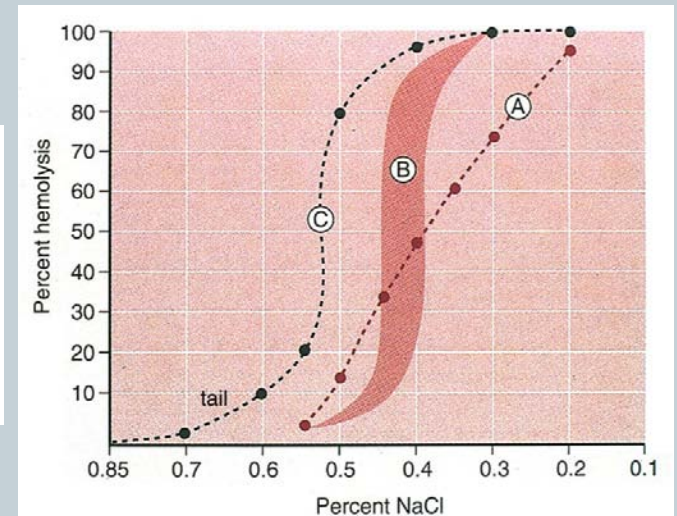

A: Thalassemia

B: Normal

C: Hereditary spherocytosis

Spherocyte EMA (eosin-5-maleimide) binding assay

31

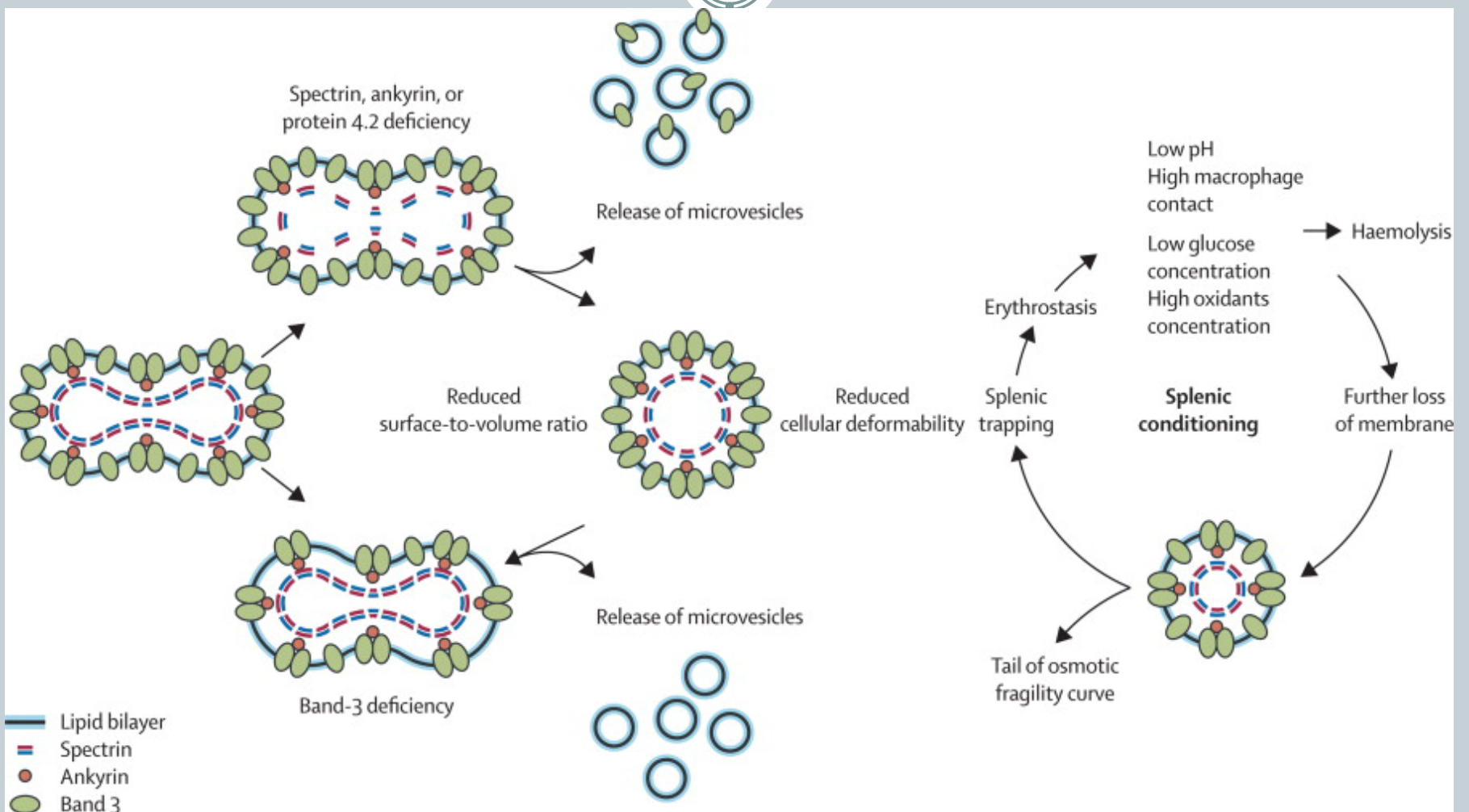

Hereditary spherocytosis (HS)

Hematological findings

- Anemia
- Reticulocytosis (5-20%)
- Microspherocytes
- Increased osmotic fragility
- Fluorescent flow analysis of eosin-5-maleimide (EMA) bound to band 3
- The direct antiglobulin (Coombs) test is normal

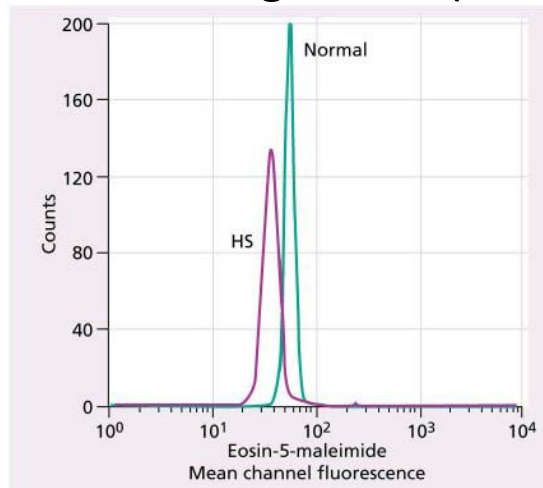
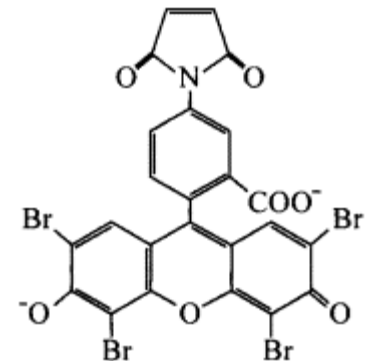
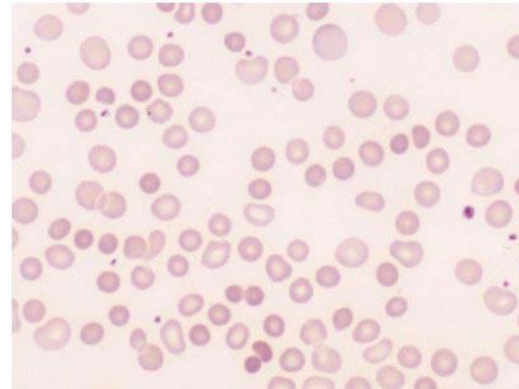

Osmotic fragility test

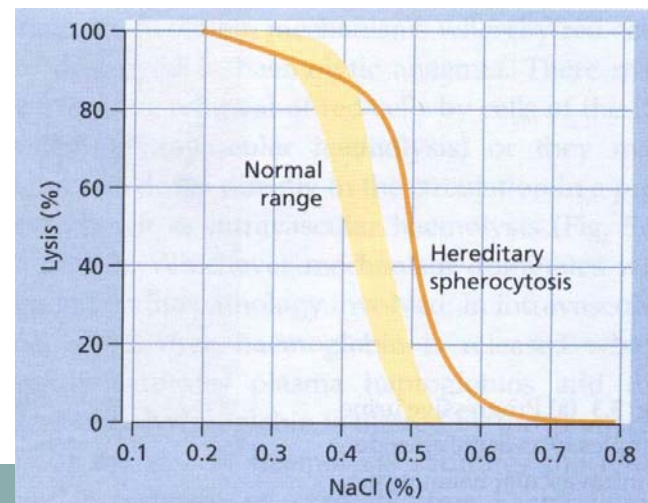

Eosin-5-maleimide staining in HS showing reduced mean channel fluorescence due to membrane band 3 protein deficiency.

Spherocyte EMA (eosin-5-maleimide) binding assay

33

- EMA covalently links Lys-430 on the first extracellular loop of band 3 protein in red cell membrane
- Excited at 488nm and emission at 525-550nm (green)

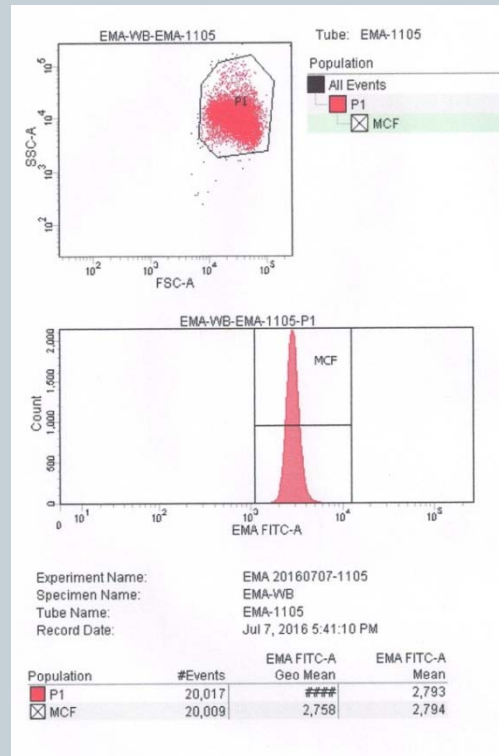
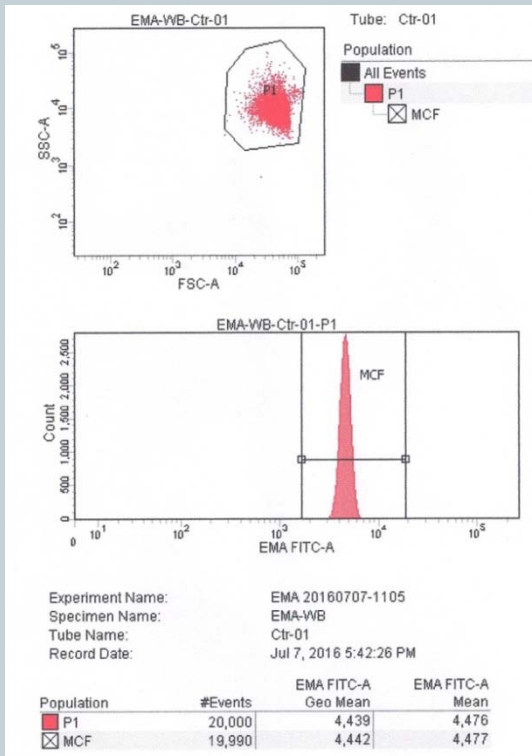

Mean of 6 MCF's for negative controls: 4310.8

MCF for patients: 2758

Ratio for patient's MCF = $2758/4310.8 = 0.64$

Interpretation: the result shows low EMA intensity, compatible with hereditary spherocytosis ($R < 0.8$)

Squeezing for life-properties of RBC deformability

34

- Deformability is an essential feature of blood cells (RBCs) that enables them to travel through even the smallest capillaries of the human body.
- Deformability is a function of
 - (i) structural elements of cytoskeletal proteins
 - (ii) processes controlling intracellular ion and water handling
 - (iii) membrane surface-to-volume ratio.
- The resulting secondary processes that affect RBC deformability (such as secondary changes in RBC hydration, membrane protein phosphorylation, and RBC vesiculation).
- These secondary processes could play an important role in the premature removal of the aberrant RBCs by the spleen.
- Altered RBC deformability could contribute to disease pathophysiology in various disorders of the RBC.

Squeezing for life-properties of RBC deformability

35

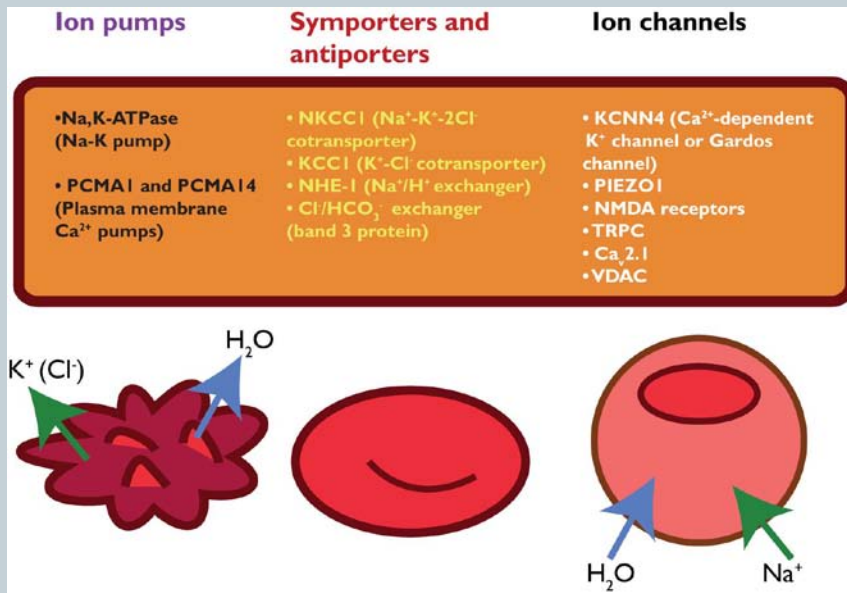

- Red blood cell deformability is highly influenced by RBC volume control and by ion content, both regulated by ion pumps, ion channels, symporters and antiporters.
- When ion channels are open, ions move following their electrochemical gradients, while ion pumps can actively move these ions against the gradient.
- Symporters and antiporters may also create secondary ion gradients, but require the pre-existing gradients for at least one type of ions as a driving force to transport the other ion types against the gradient.

The sensing of poorly deformable red blood cells by the human spleen can be mimicked in vitro

36

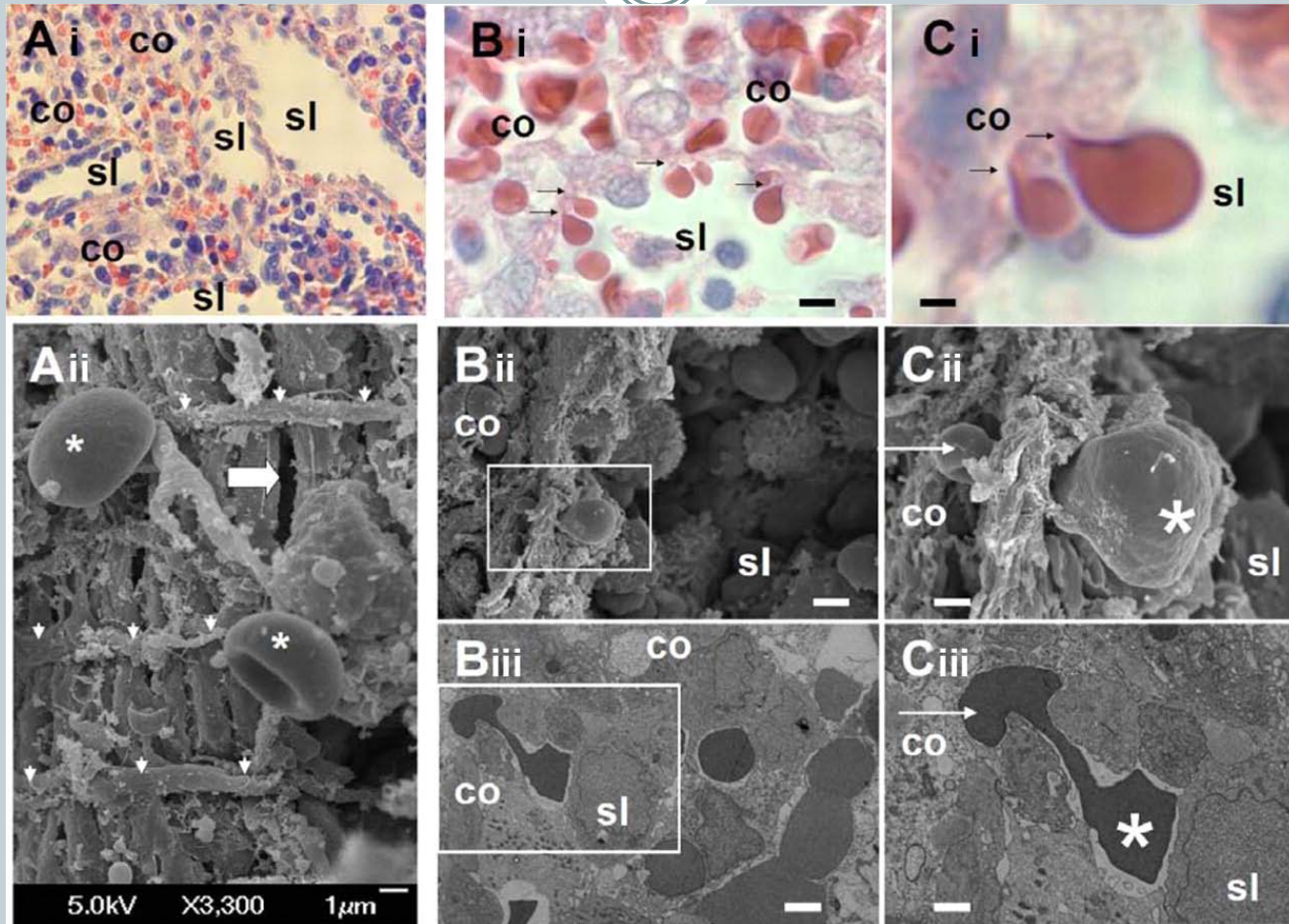

Fine structure of interendothelial slits in the sinus wall of the human splenic red pulp.

The sensing of poorly deformable red blood cells by the human spleen can be mimicked in vitro

37

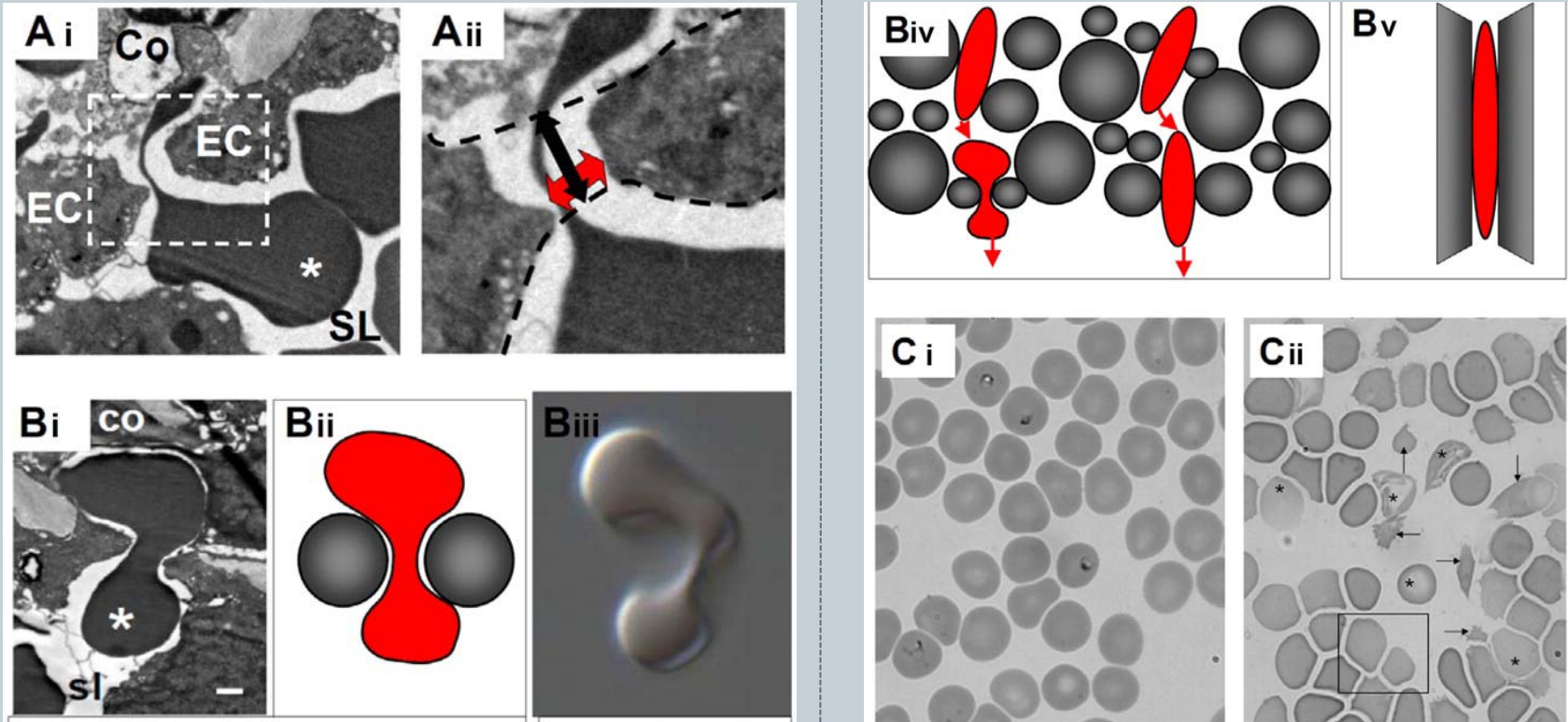

Size and geometry of the interendothelial slit and resulting RBC deformation.

(A) TEM (Ci) normal RBC (Cii) dacryocytes, schizocytes, poikilocytes

The sensing of poorly deformable red blood cells by the human spleen can be mimicked in vitro

38

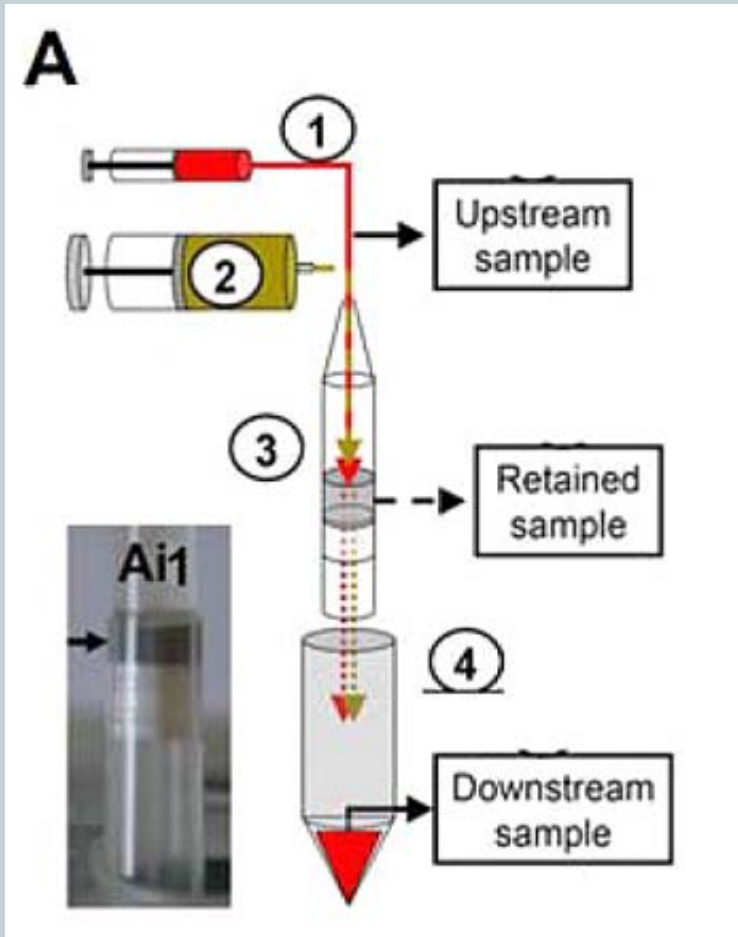

- Decantation of microbeads after their introduction into an inverted 1000- μ L tip, leading to the formation of a 5-mm-thick bead layer (black arrow) above the antiaerosol filter (Ai1).
- RBCs were resuspended at 2% hematocrit in medium (PBS/1% albumin) and then introduced in the tubing upstream from the microbead layer (①). An electric pump containing medium was then immediately switched on (②), gently flowing RBCs through the microbead layer (③). On rinsing of the microbead layer with 7 mL of medium, the downstream sample was retrieved (④).

Poorly deformable RBC flow-through microbeads: setup and results.

The sensing of poorly deformable red blood cells by the human spleen can be mimicked in vitro

39

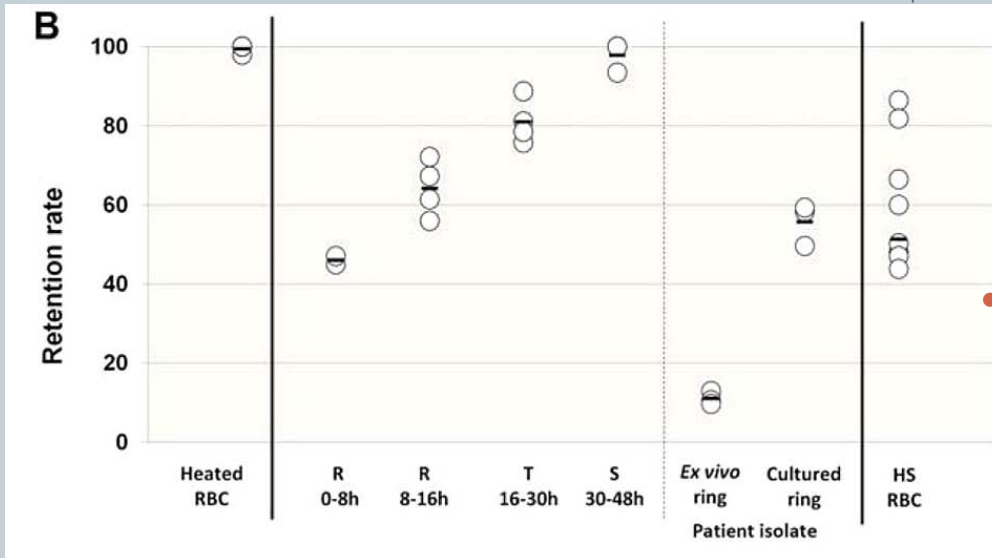

- Retention rate of heated, HS, and Pf-RBCs: Heated normal RBCs (50°C for 20 minutes) or HS-RBCs were PKH-labeled and retention rate expressed as the $\Delta = \{[(\% \text{ of PKH-positive RBC in downstream sample}) - (\% \text{ of PKH-positive RBC in upstream sample})] / (\% \text{ of PKH-positive in the upstream sample})\} \times 100$.
- Retention in the microbeads was partial at the ring stage (R), subtotal at the trophozoite stage (T), and complete at the schizont stage (S). When ring-RBCs from patients' blood were immediately processed (ex vivo ring), retention rate was low; but on culture to the next generation of ring-RBCs (cultured ring), the mean retention rate was similar to that observed with reference laboratory isolates maintained in long-term culture.

Poorly deformable RBC flow-through microbeads: setup and results.

A biomimetic microfluidic chip to study the circulation and mechanical retention of red blood cells in the spleen

40

A Filter Design

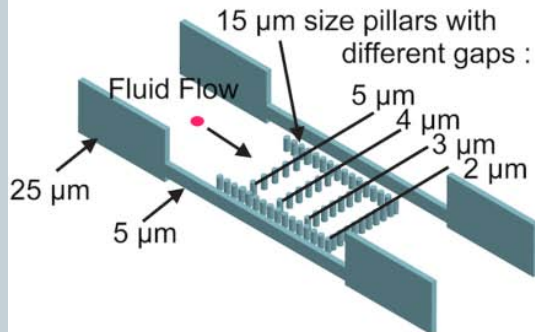

B Process flow

Microchannels (thickness = 5 μm)



Microfluidic access (thickness = 25 μm)



PDMS Casting



PDMS Bonding on Glass wafer

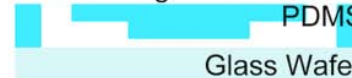

C SU8 and PDMS manufacture

SU8 mold



PDMS device

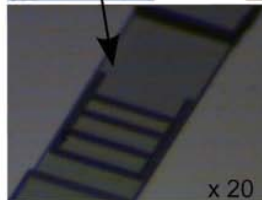
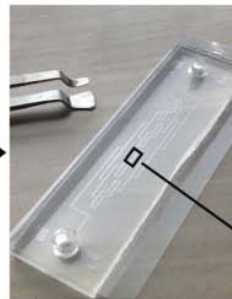

SU8 mold of the filtering unit

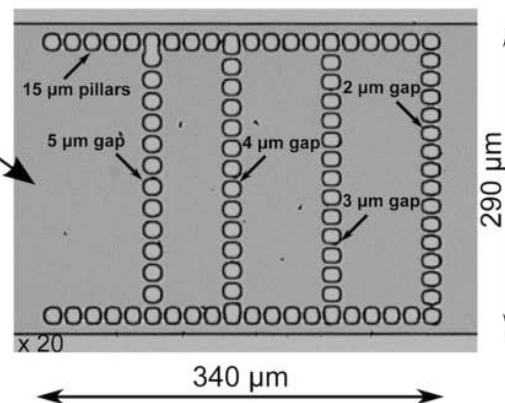

Top view of the microfabricated filtering unit

A biomimetic microfluidic chip to study the circulation and mechanical retention of red blood cells in the spleen

41

- RBC deformability
- Microfluidic chip
- Each filtering unit comprises of fifty-three 2- μm -wide slits between the 15- μm pillars that form the boundaries of the lattice.
- The inner pillar lines comprise 12, 13, and 14 slits, the width of which is 5, 4, and 3 μm , from left to right.
- The U-shaped filter is 275- μm -wide (including pillars) included a single $\times 20$ microscopic field captured by the camera sensor ($18.6 \times 6.7 \text{ mm}^2$) Side channels are 10- μm -wide.
- The filtering unit is 5- μm -high.
- Microfluidic channels connecting the eight filtering units are 25- μm -high to minimize hydraulic resistance between filtering units

A biomimetic microfluidic chip to study the circulation and mechanical retention of red blood cells in the spleen

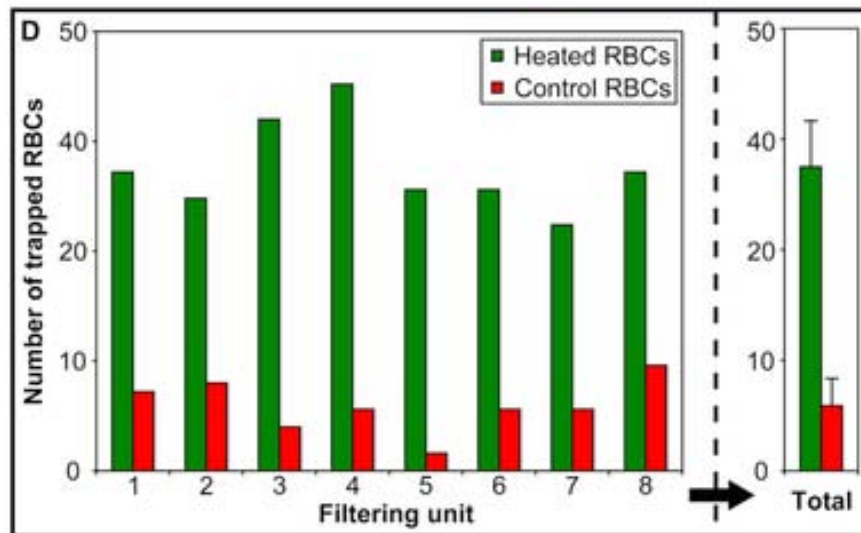
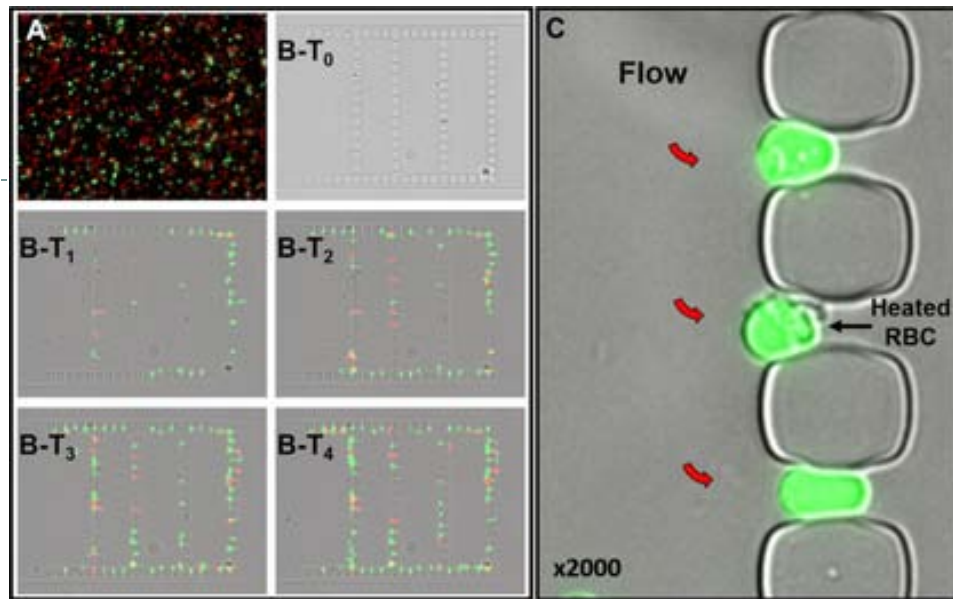

A microfabricated deformability-based flow cytometer with application to malaria

43

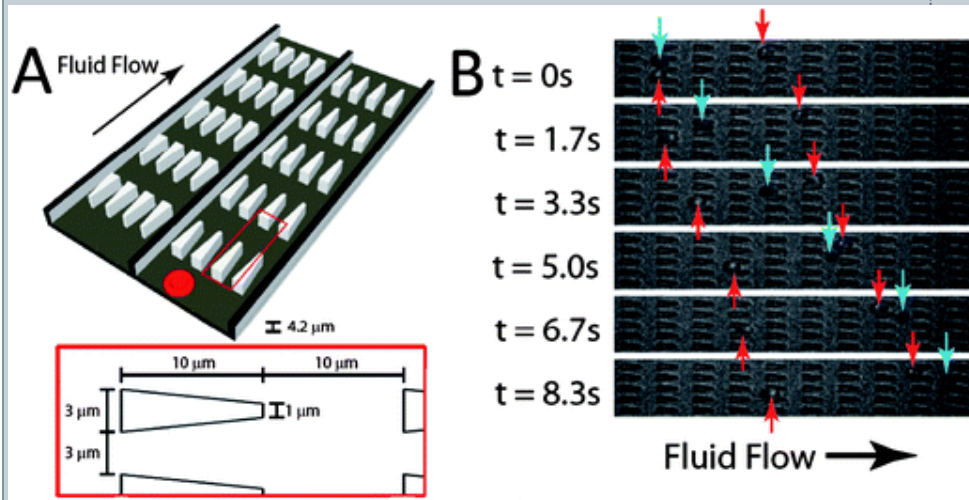

- (A) Illustration of the device design; each channel of the actual device is 10 pores wide and 200 pores long.
- (B) Experimental images of ring stage *P. falciparum*-infected (red arrows) and uninfected (blue arrows) RBCs in the channels at a pressure gradient of $0.24 \text{ Pa } \mu\text{m}^{-1}$. The small fluorescent dot inside the infected cell is the GFP-transfected parasite. At 8.3 s, it is clear that the uninfected cell moved about twice as far as each infected cell.

A microfabricated deformability-based flow cytometer with application to malaria

44

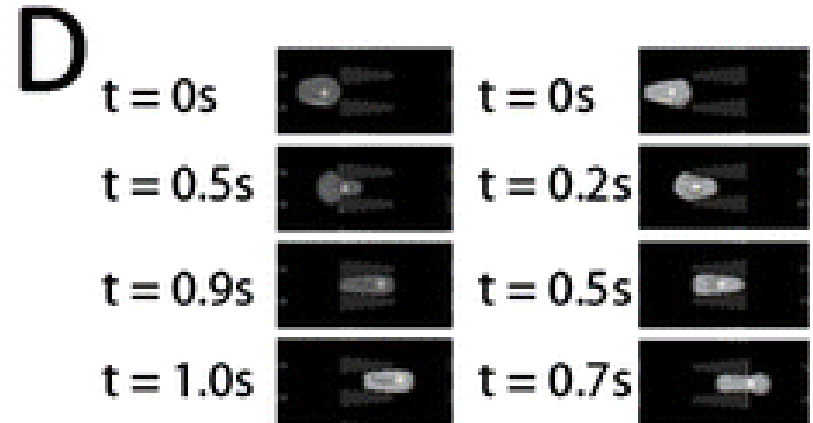
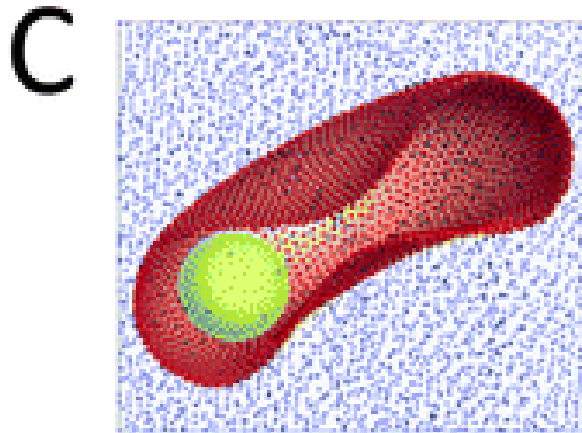

- (C) The computational RBC model consists of 5000 particles connected with links. The *P. falciparum* parasite is modeled as a rigid sphere inside the cell.
- (D) DPD simulation images of *P. falciparum*-infected RBCs traveling in channels of converging (left) and diverging (right) pore geometry at $0.48 \text{ Pa } \mu\text{m}^{-1}$

Velocity vs. cell maturation state

45

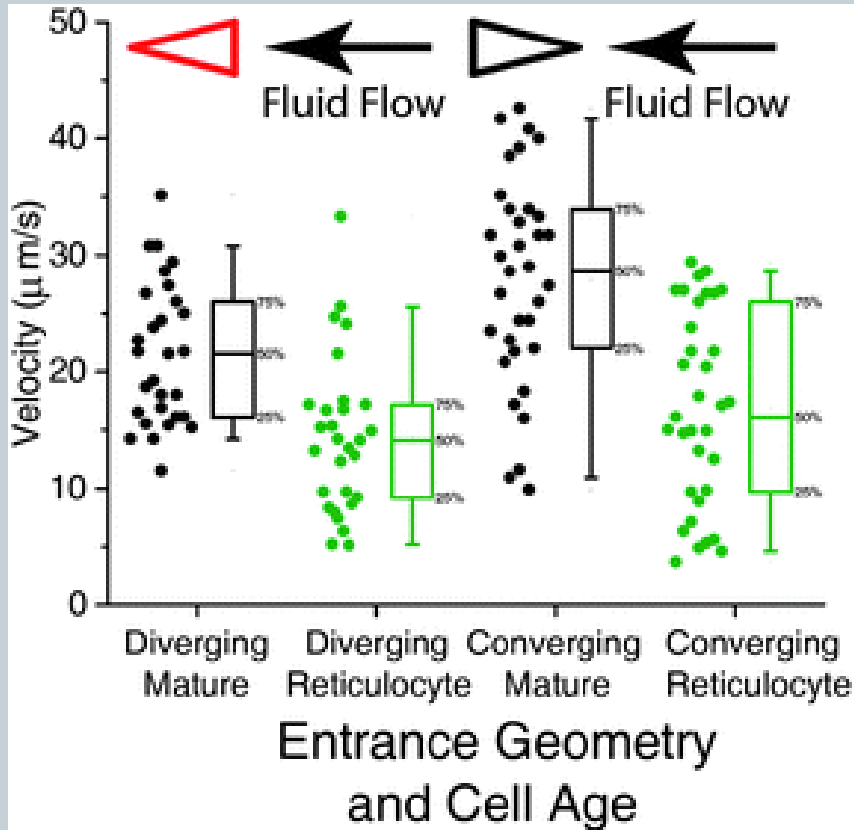

- All experiments were run simultaneously, at a pressure gradient of $0.24 \text{ Pa } \mu\text{m}^{-1}$. Whole blood RBCs were stained for nucleic acid content with thiazole orange.
- Cells homogeneously fluorescing under the GFP filter set were identified as reticulocytes.
- For every reticulocyte that was identified and tracked for $200 \mu\text{m}$, the next cell appearing in the field of view was also tracked



THE END!