



National Taiwan University



Fabrication Processes

微奈米機電製程概述

Speaker : 林順區 博士

Date : 2018/10/05



微奈米機電製程概述及無塵室介紹及參訪 10/5

無塵室黃光微影及蝕刻製作 11/16

授課者-林順區 博士

現任: 國立臺灣大學奈米機電系統研究中心
博士研究員

經歷: 台灣積體電路股份有限公司(台積電)主任工程師
海巡署通資作業大隊少尉區隊長(服役)司法警察
國立台灣大學工學院博士
國立台灣大學工學院碩士





你知道什麼是微奈米機電(MEMS or NEMS)嗎?

微機電為什麼又叫微奈米機電(MEMS or NEMS)呢?



Outline

- Introduction to MEMS Technologies
- Clean room
- Silicon Wafers
- Photolithography
- Film Vapor Deposition
- Silicon Etching Technique
- LIGA,UV-LIGA,SIGA
- Conclusions



Introduction to MEMS Technologies

Introduction (1) — Father of MEMS

- 理查·費曼的演講
- 1959年，美國物理學會年會演講

「There is plenty of room at the bottom」
底下的空間還大的很

- 書本上的字句縮小25,000倍



理查·費曼

微機電系統技術的發展背景

- 微機電系統技術起源於1960年代對積體電路的研究
- 發展的理念在於如何將電子電路微小化
- 科技人員改善傳統加工技術及應用半導體製程，試圖將各種機械元件微小化，進而產生微機電系統技術

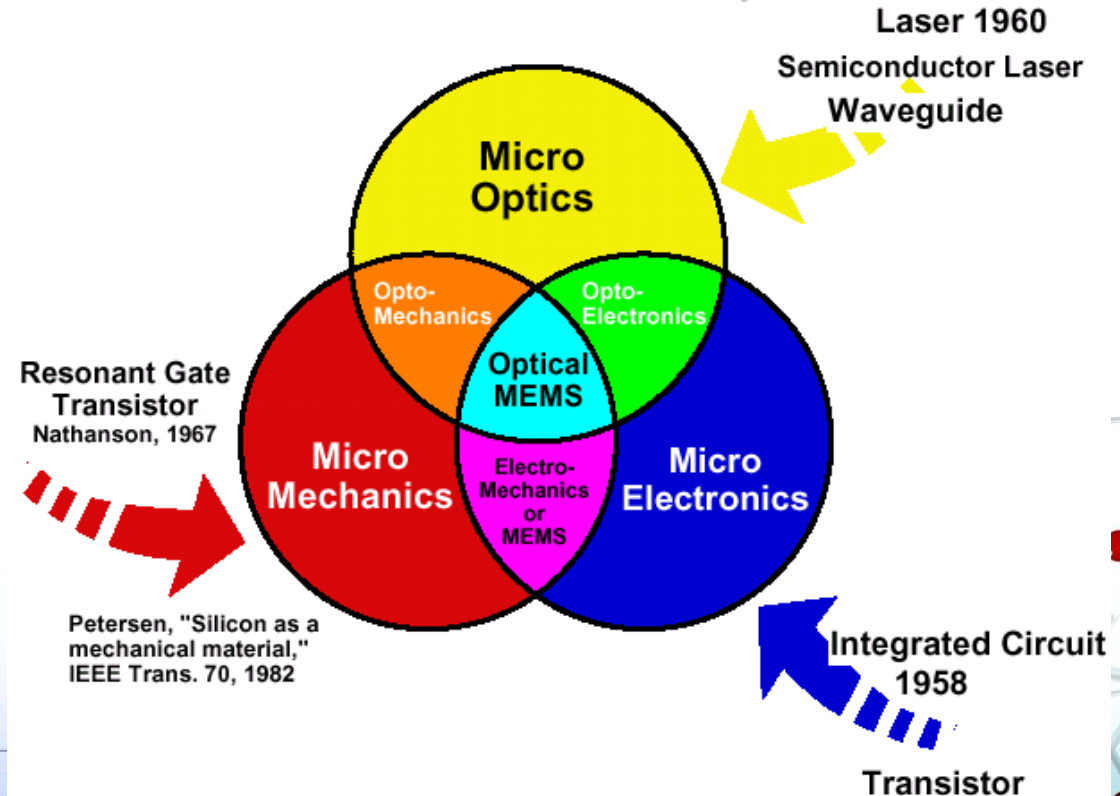
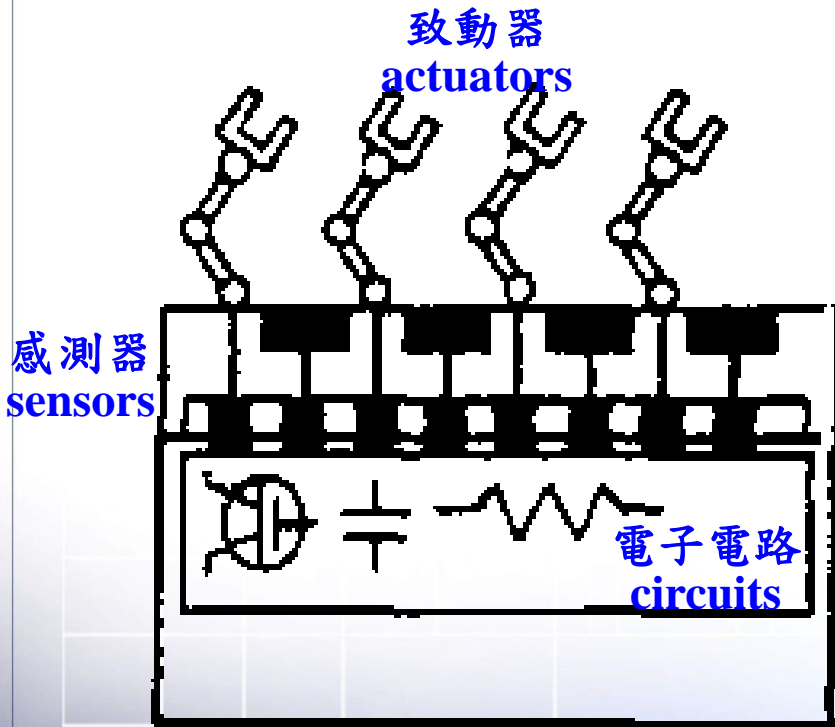

Introduction (2) — What's MEMS ?

微機電系統名稱分類

美國：**M**icro-**E**lectro-**M**echanical **S**ystem (MEMS)

日本：Micromachines

歐洲：**M**icro-**S**ystems **T**echnology (MST)

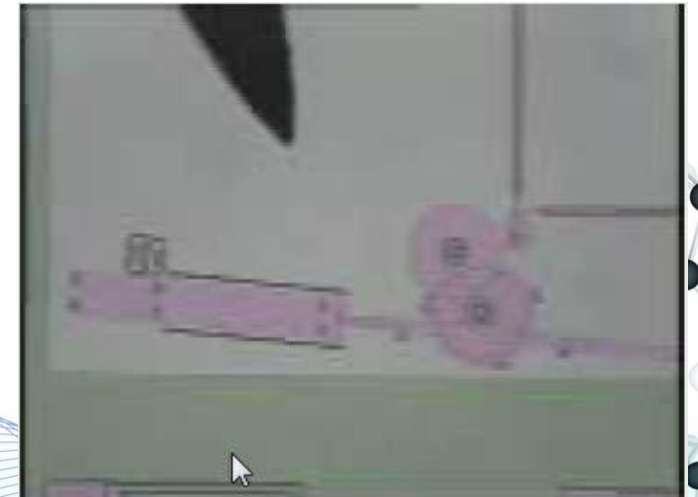
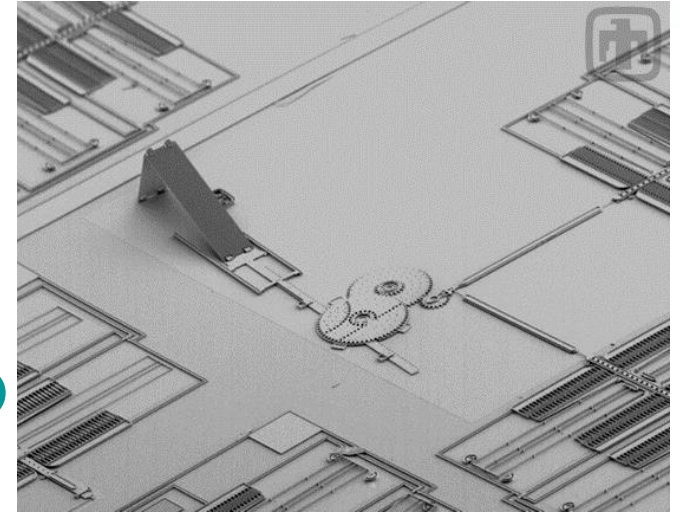

Sandia National Lab., USA

Introduction (3) — MEMS Technologies

微機電系統產品的優點

- 超「輕、薄、短、小」
- 高附加價值
- 符合環保、省能源
- 省空間、省材料等



質譜儀

70 Kg, 30000 cm³, 1200 W

Europa Scientific, UK

微機電系統技術

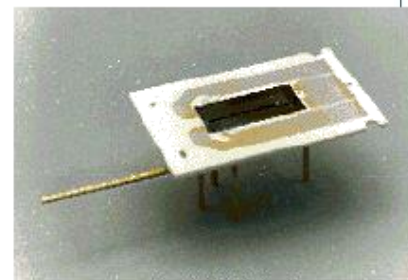

微質譜儀晶片

0.2 Kg, 3 cm³, 0.5 W

DARPA, USA

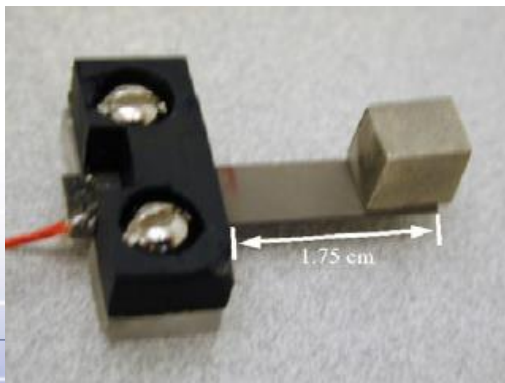

MEMS

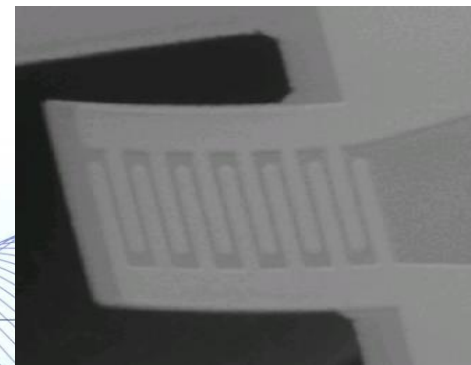

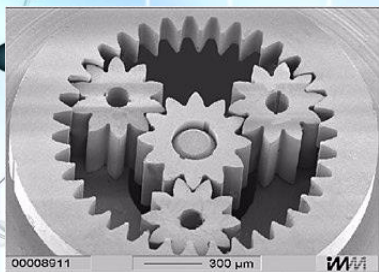

(a) 微齒輪組

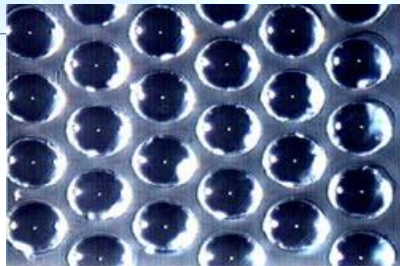

(b) 微鏡片

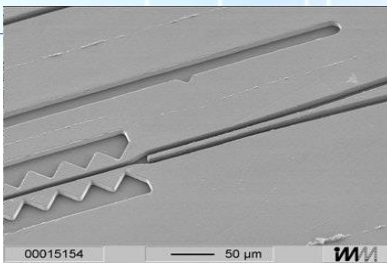

(c) 整合光學分光器

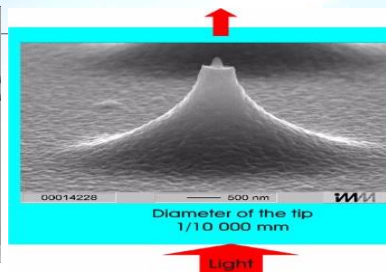

(d) 近場光學探針

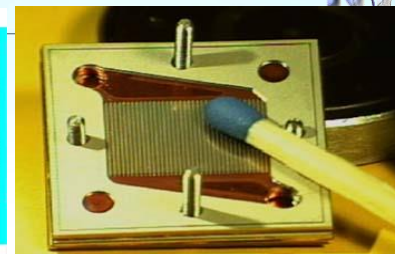

(e) 微熱交換器

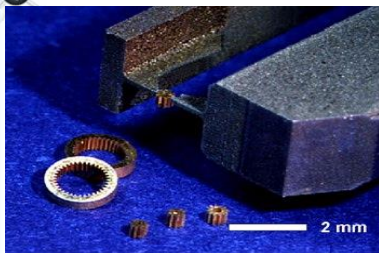

(f) 微組合

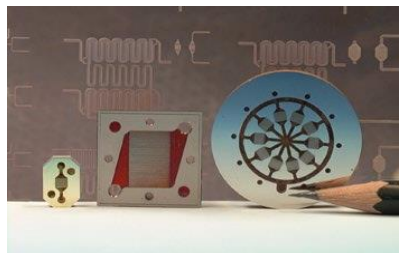

(h) 微幫浦



(g) 微反應器

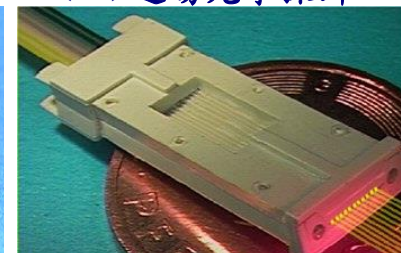

(i) 光纖固定器



(j) 微馬達

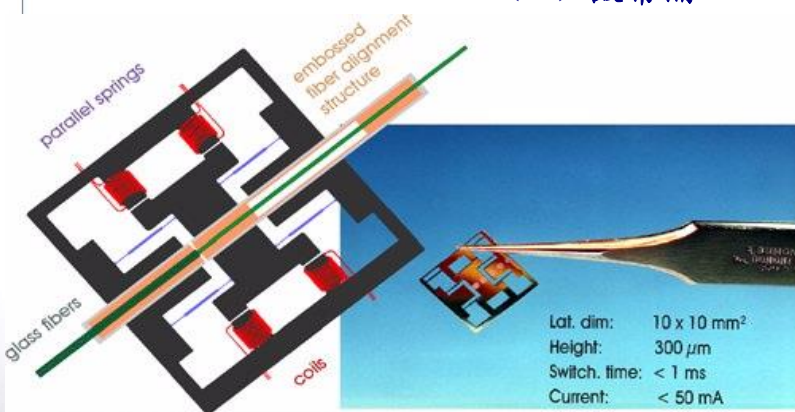

(k) 光纖開關

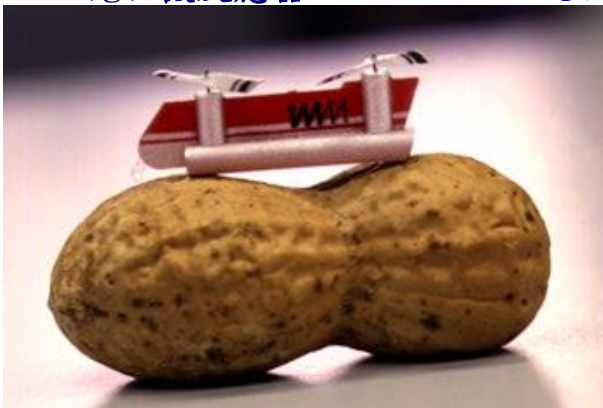

(l) 微小直升機



IMM 微系統研究中心

IMM微系統研究中心所開發的產品
Source: <http://www.imm-mainz.de>

high aspect ratio

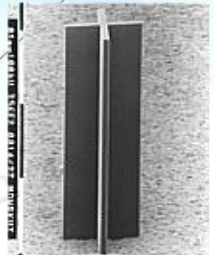

Bar structure 400 μm high, with parallel sidewalls.

any lateral shape

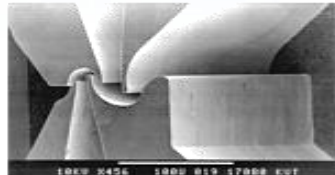

Separation nozzle as an example of arbitrary lateral shaping.

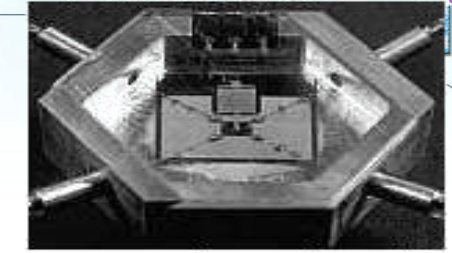
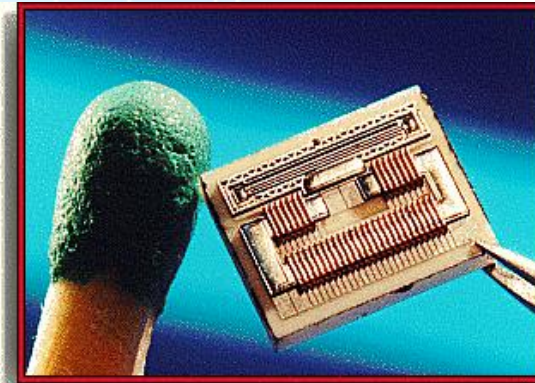

Micro-optical bypass switch with electrostatic actuator for moving a mirror.

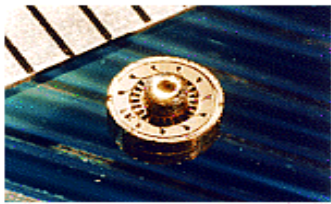

Microturbine ($\phi = 2.5 \text{ mm}$) for cardiac catheters, power: 40 mW

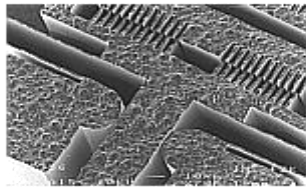

Nickel structure of an electrostatic linear actuator after electroforming and dissolution of the remaining resist parts. The structure height is 80 μm .

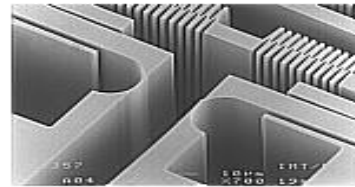

Detail of a 100 μm high PMMA structure of an electrostatic linear actuator. The smallest lateral PMMA structure is 1 μm and forms the gap between the conical capacitor plates.



Micromembrane pump from the small series manufactured at the Research Center, as compared to the size of an ant.

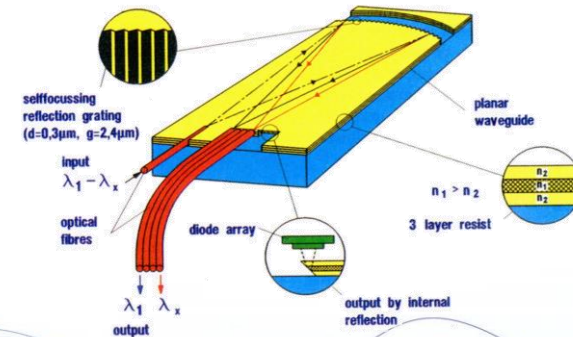
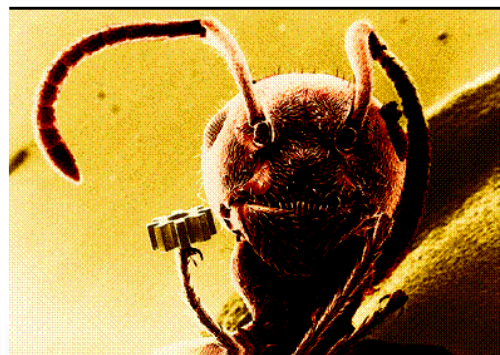
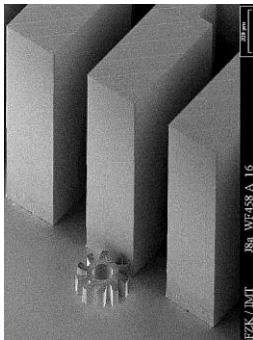

IMT微系統研究中心所開發的產品
Source: <http://www.fzk.de/imt/eimt>

IBM 千足計畫 (1)

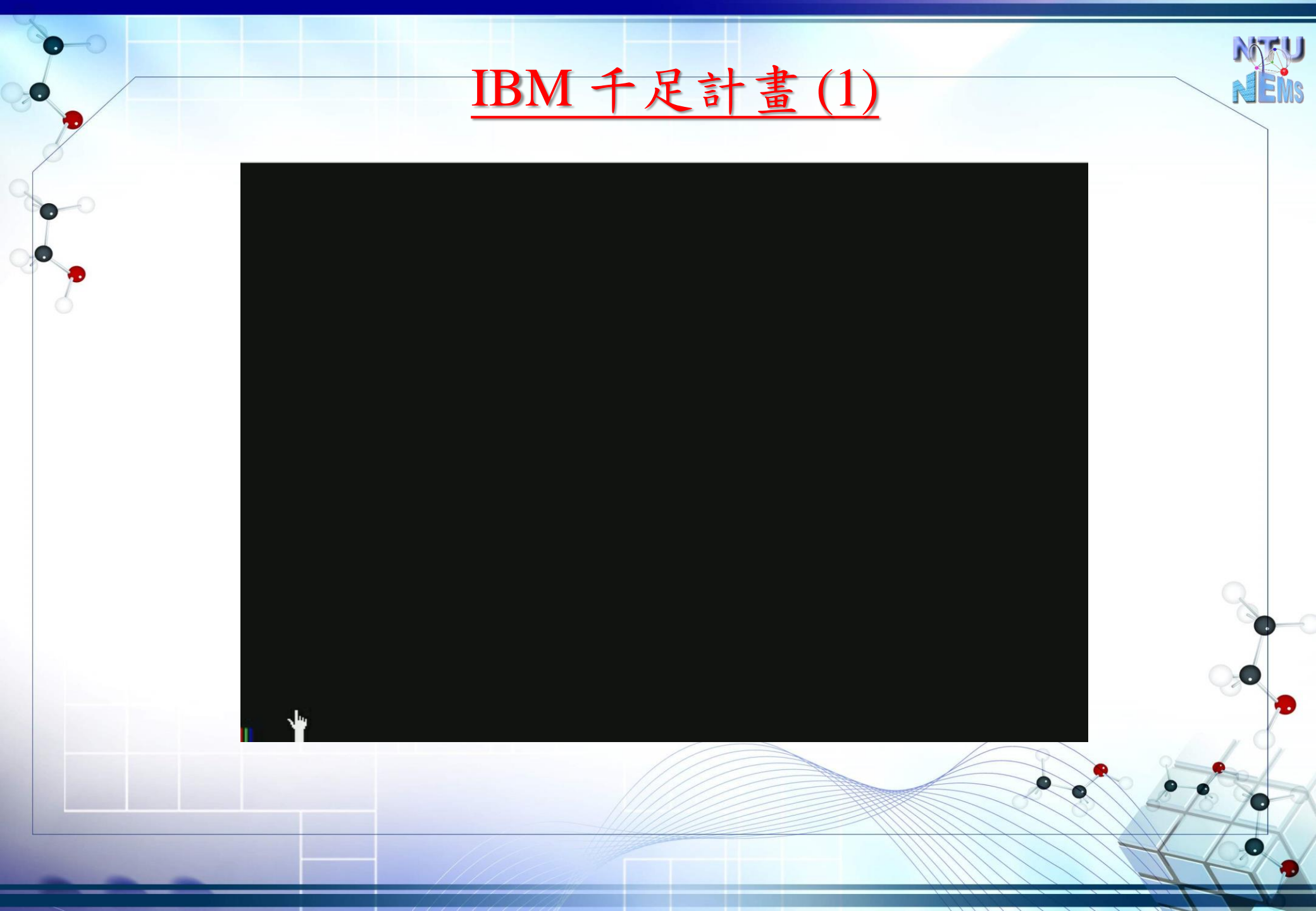

IBM 千足計畫 (2)

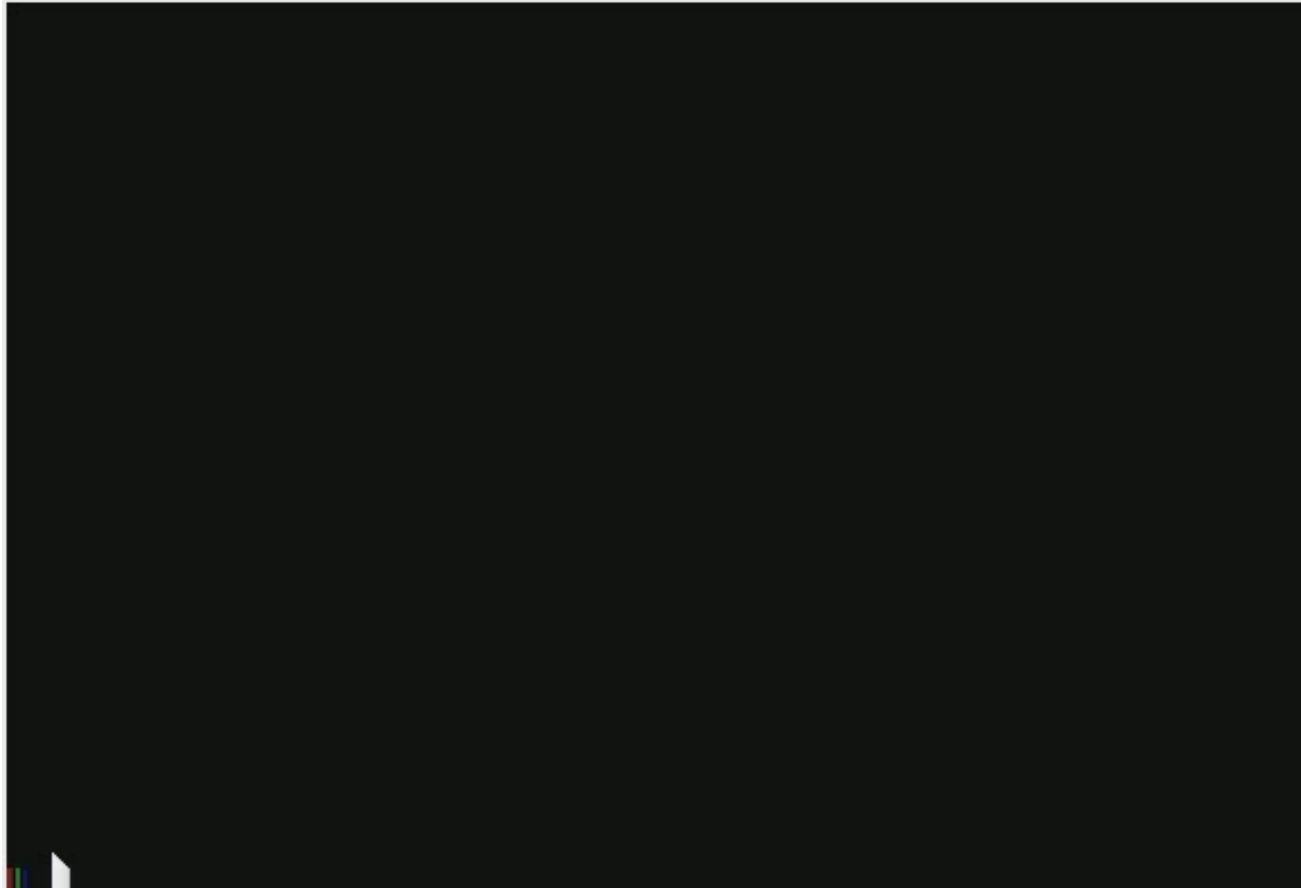

Introduction (4) — Definition

微機電系統的定義

應用微米(μm , 10^{-6} m)與奈米(nm , 10^{-9} m)加工技術研製微細元件及組件，並整合微電子電路與微控制器，而達到某種功用的系統。

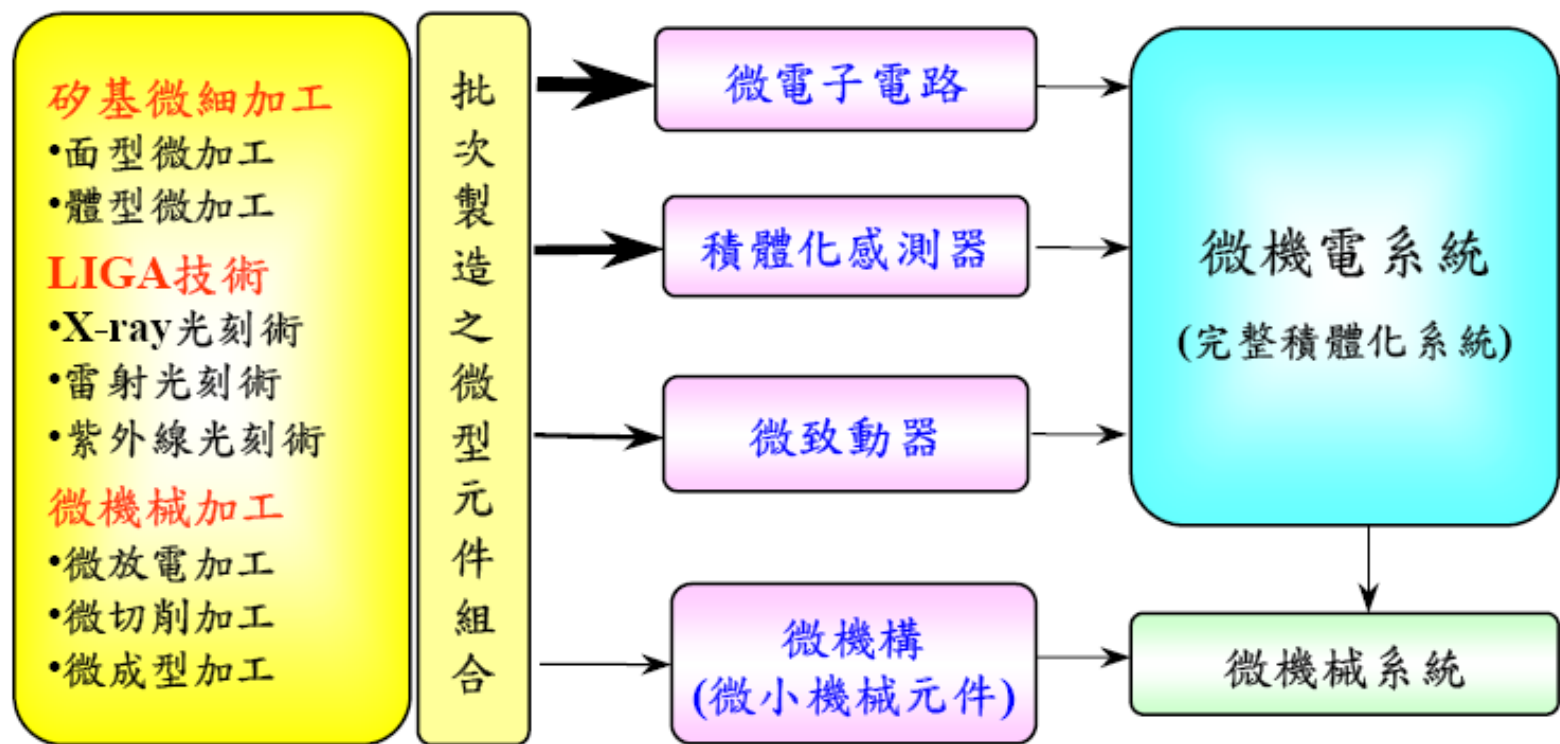

Introduction (5) — IC

半導體IC製造流程

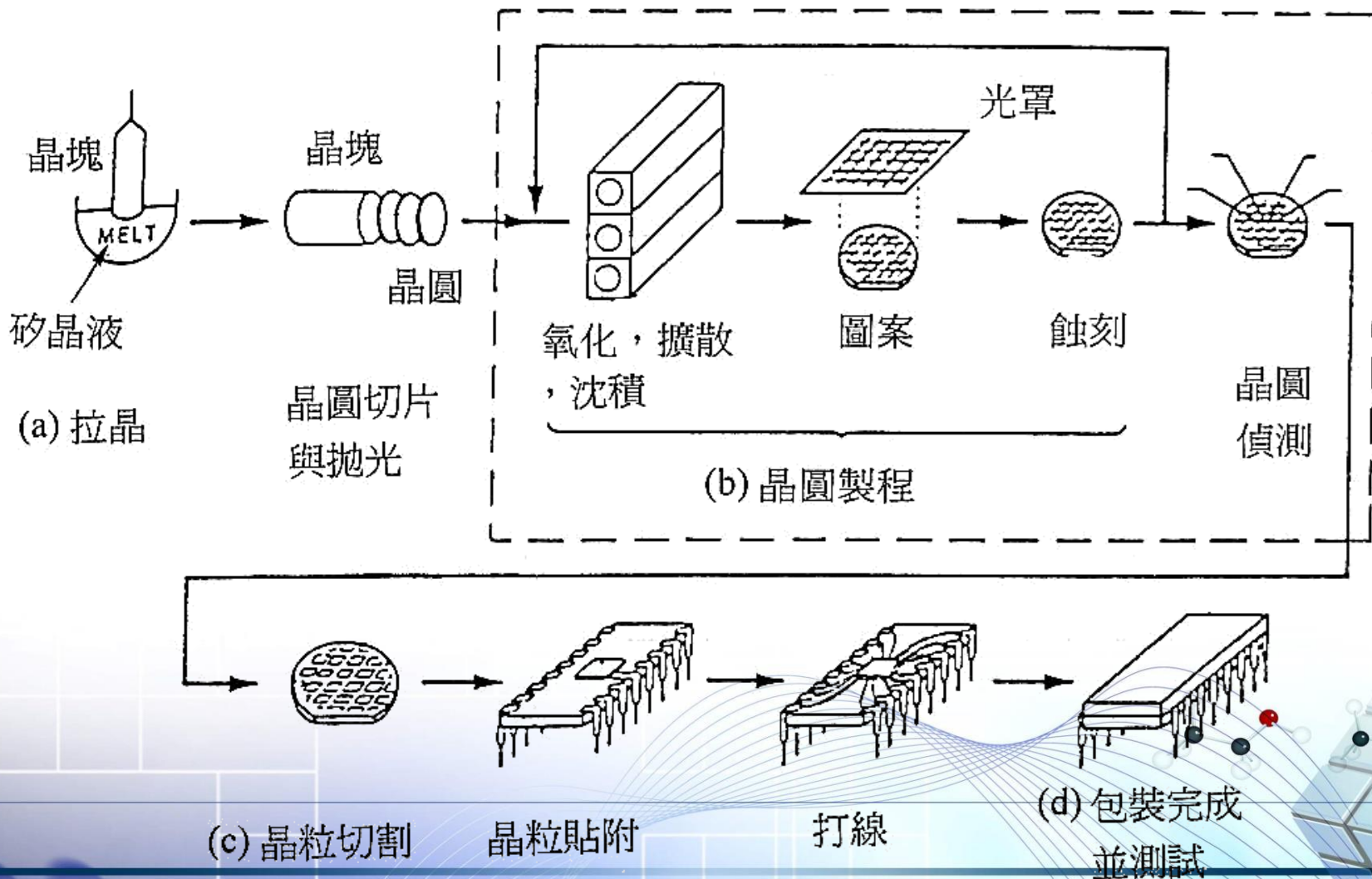

Clean room



Clean room (1) — Background

- Artificial environment with low particle counts
- Started in medical application for post-surgery infection prevention
- Particles kills yield
- IC and MEMS fabrication must in a clean room

Clean room (2) — Background

- **First used for surgery room to avoid bacteria contamination**
- **Adopted in semiconductor industry in 1950**
- **Smaller device needs higher grade clean room**
- **Less particle, more expensive to build**

Clean room (3) — Clean Room Class

- Class 10 is defined as less than 10 particles with diameter larger than $0.5 \mu\text{m}$ per cubic foot.
- Class 1 is defined as less than 1 such particles per cubic foot.
- $0.18 \mu\text{m}$ device require higher than Class 1 grade clean room.

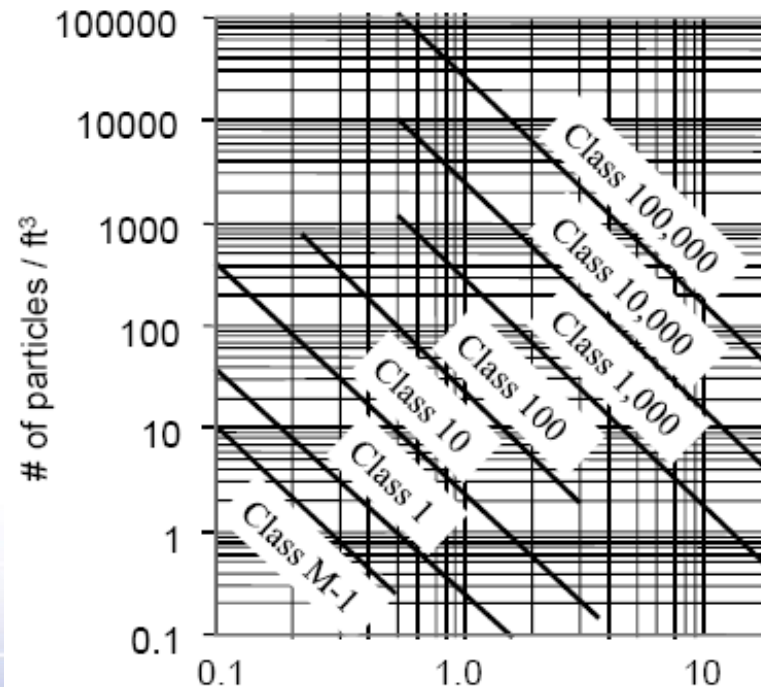

Particle size in micron

Clean room (4) — Definition of Airborne Particulate Cleanliness Class

Class	Particles/ft ³				
	0.1 μm	0.2 μm	0.3 μm	0.5 μm	5 μm
M-1	9.8	2.12	0.865	0.28	
1	35	7.5	3	1	
10	350	75	30	10	
100		750	300	100	
1000				1000	7
10000				10000	70

Clean room (5) — Effect of Particles on Masks

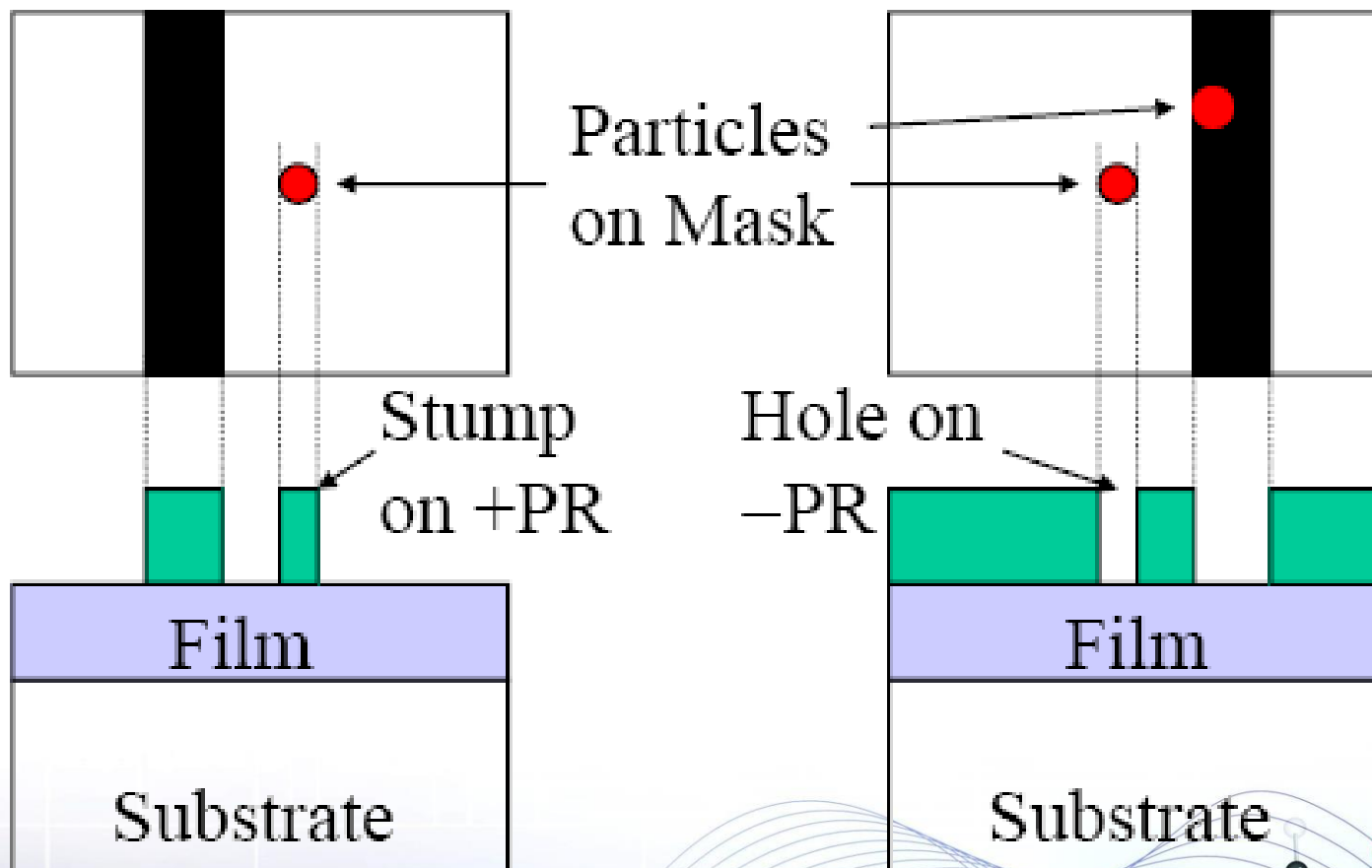

Clean room (6) — Effect of Particle Contamination

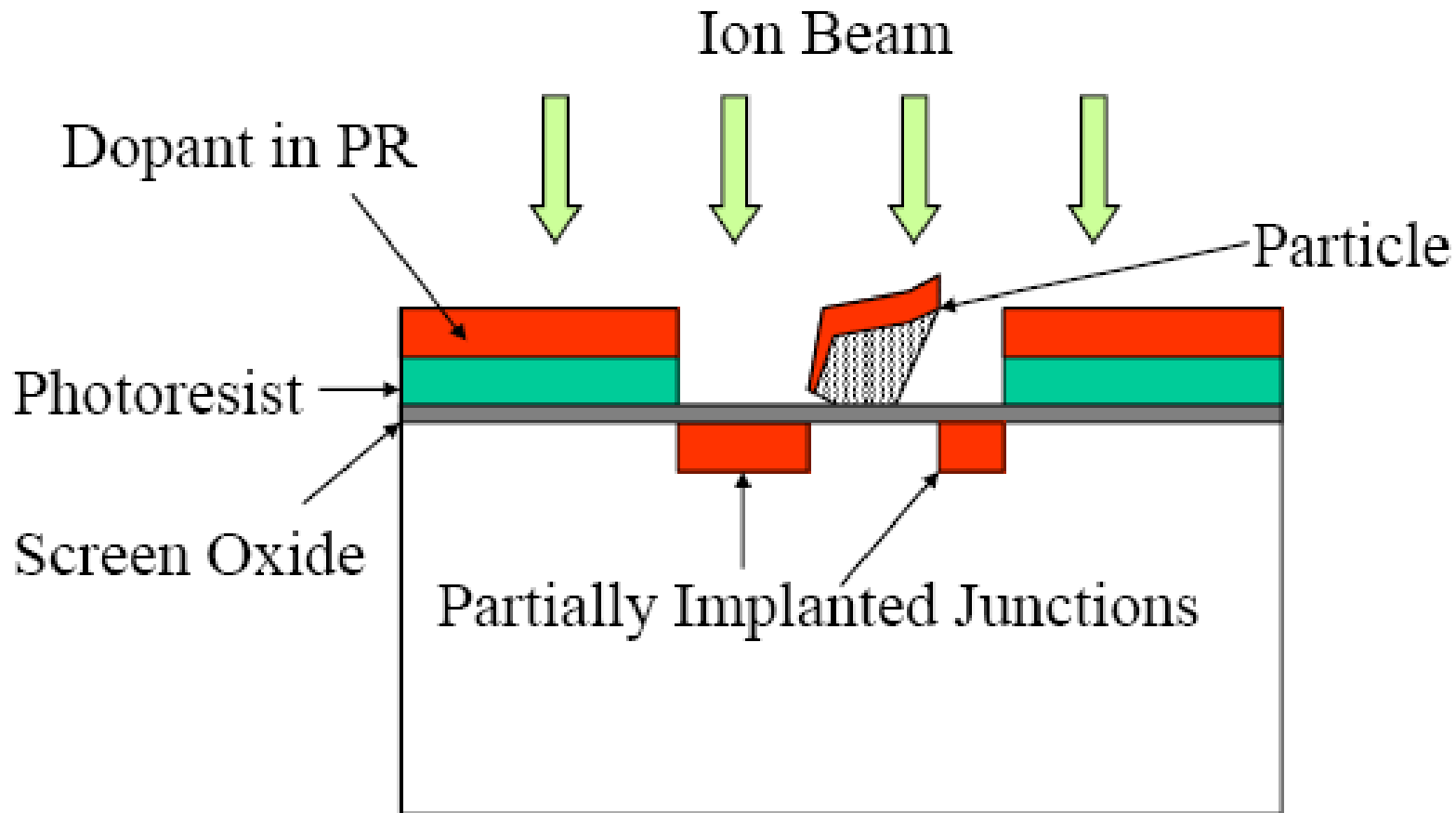

Clean room (6) — 無塵室 (Clean room or FAB) 之構成

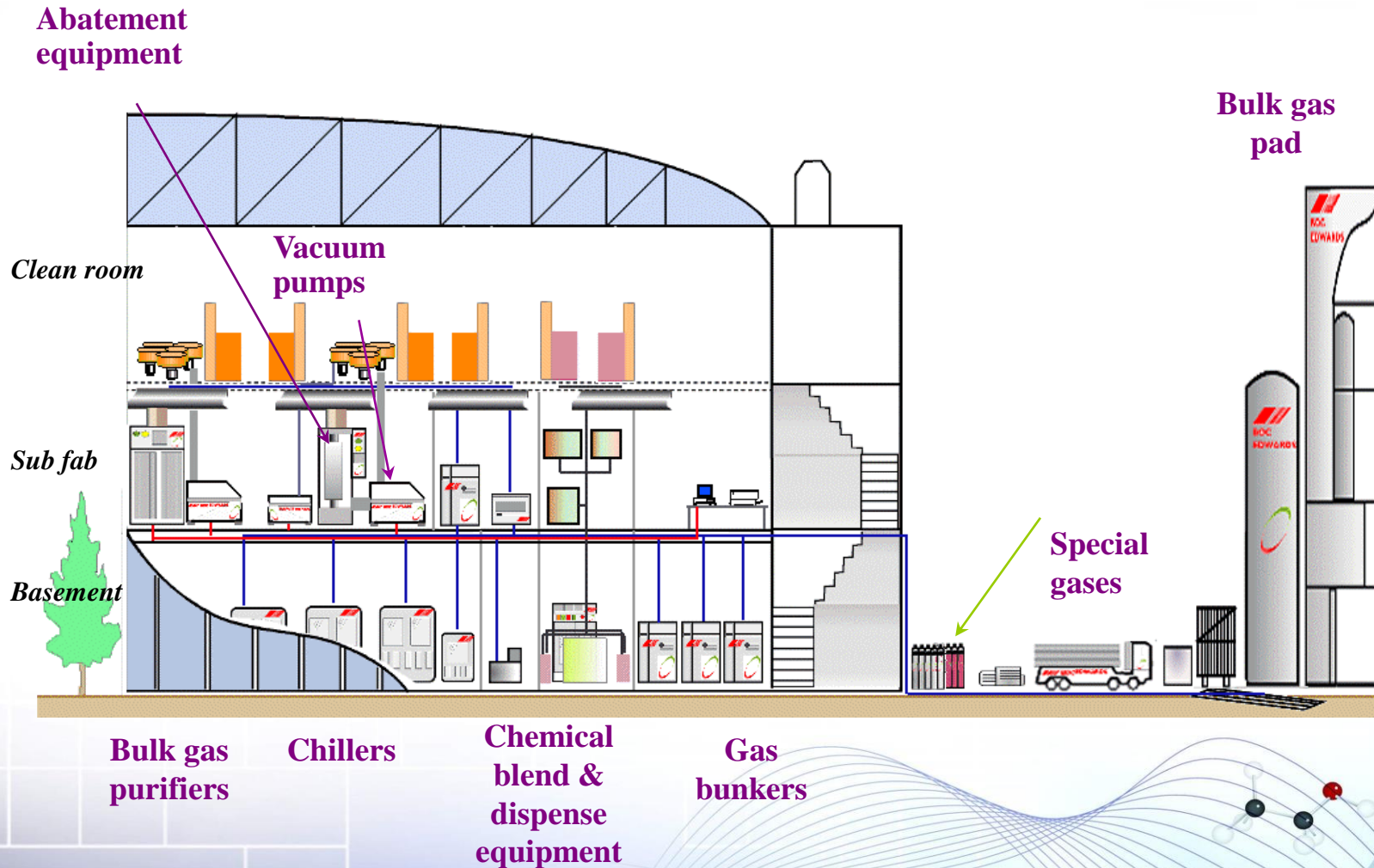

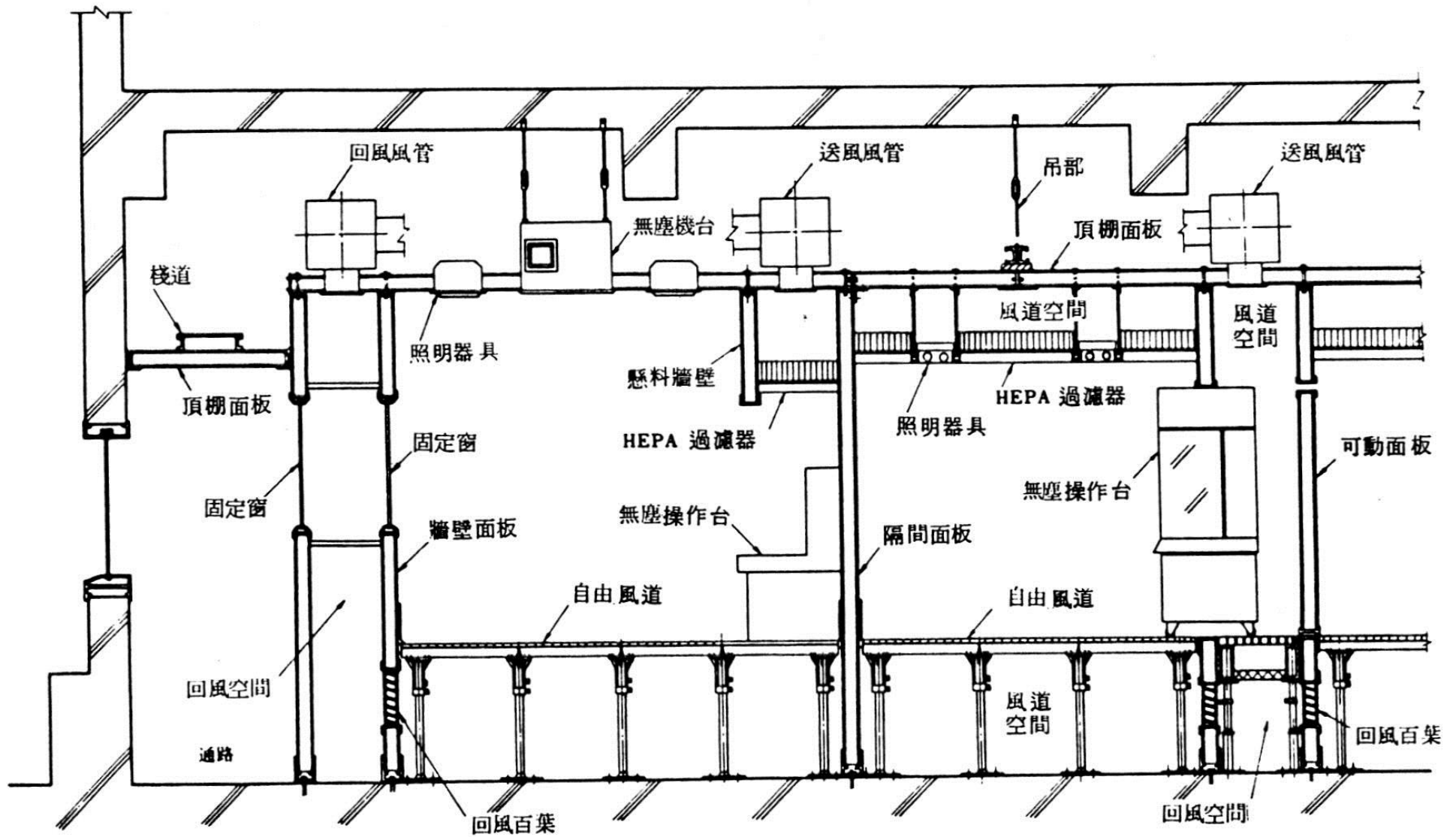

無塵室縱斷面圖

Clean room (7) — 無塵室之構成(續)

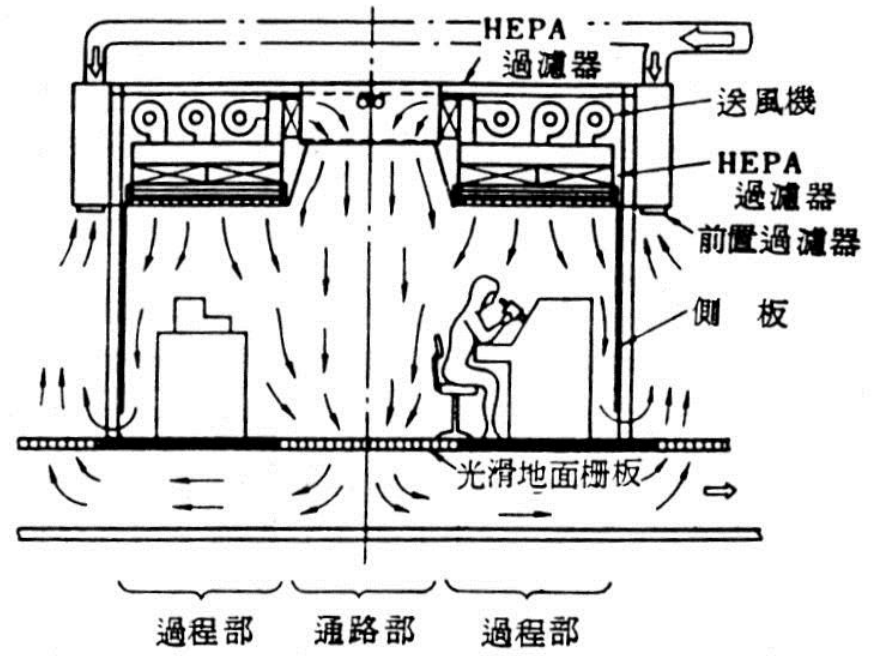
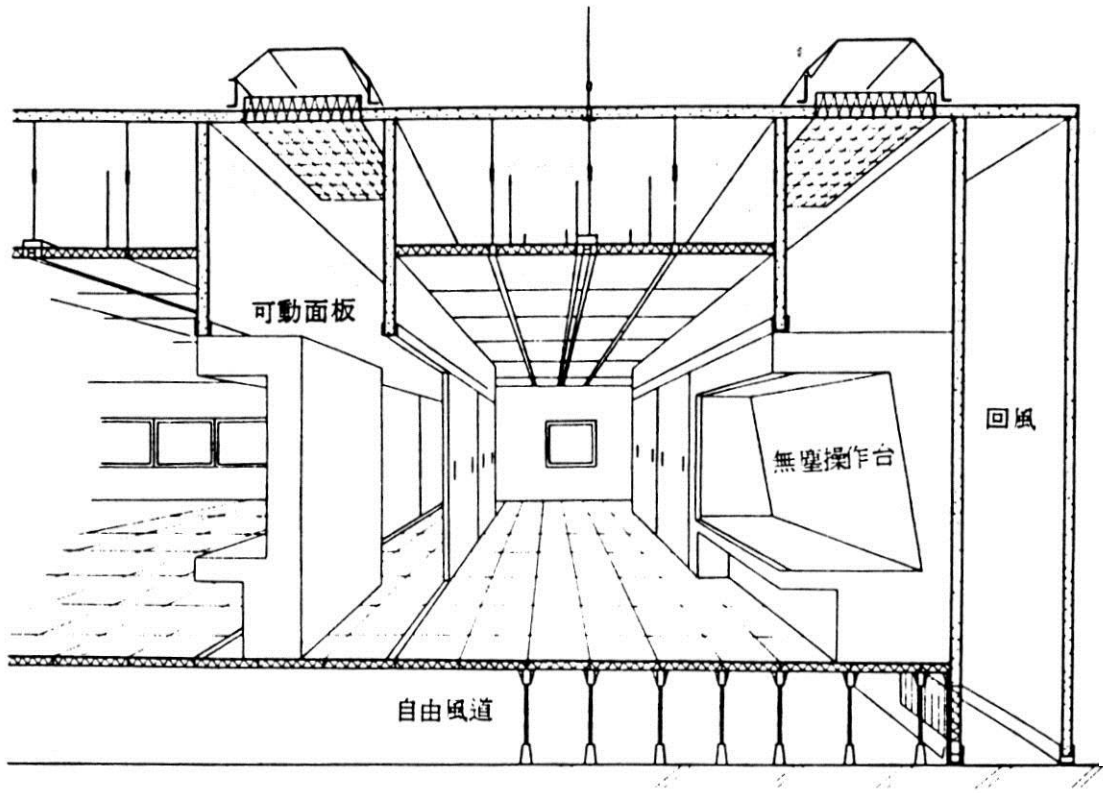

Clean room (8) — Cleanroom Structure

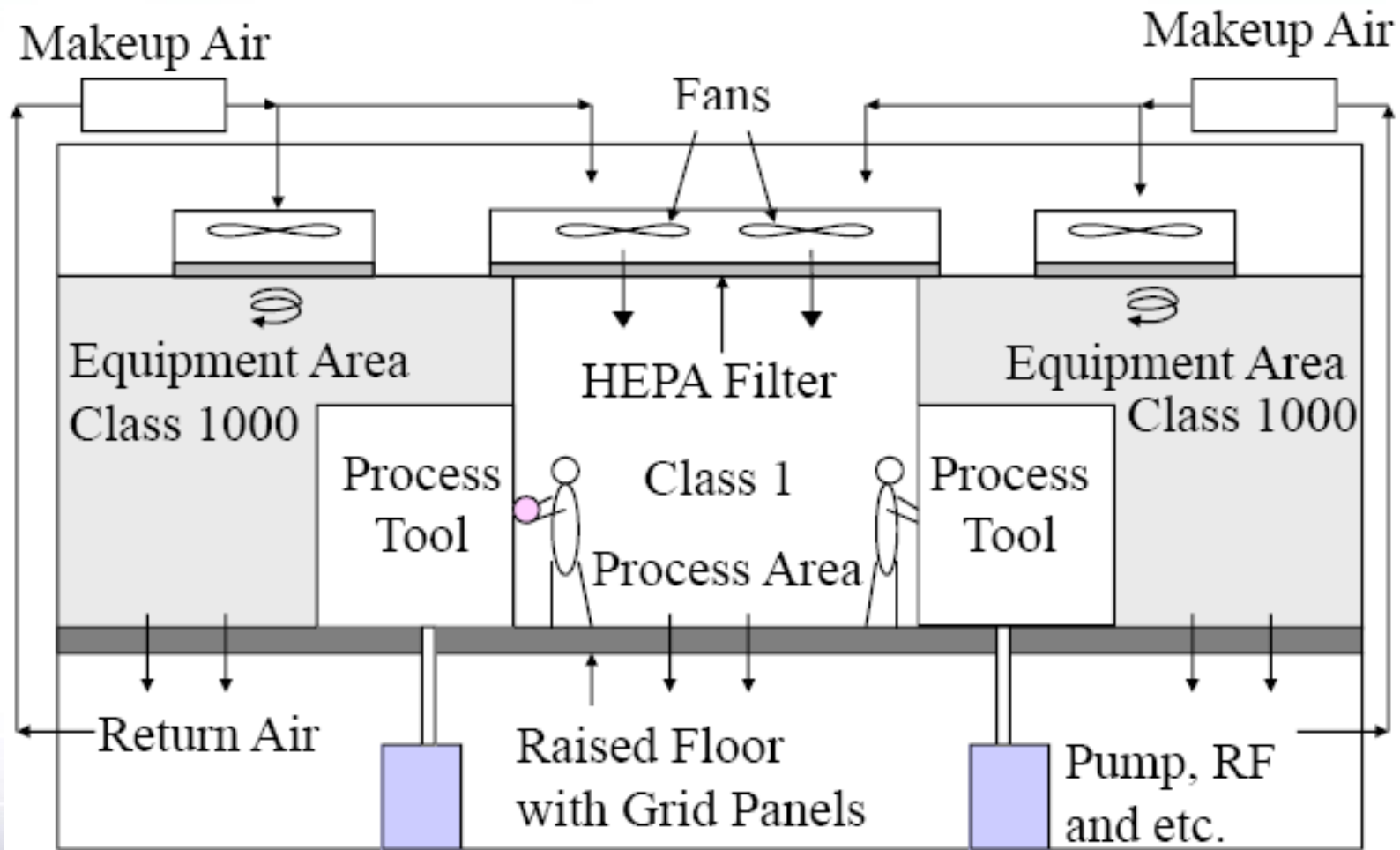

Clean room (9) — Mini-environment

- **Class 1000 cleanroom, lower cost**
- **Boardroom arrangement, no walls between process and equipment**
- **Better than class 1 environment around wafers and the process tools**
- **Automatic wafer transfer between process tools**

Clean room (10) — Mini-Environment Cleanroom

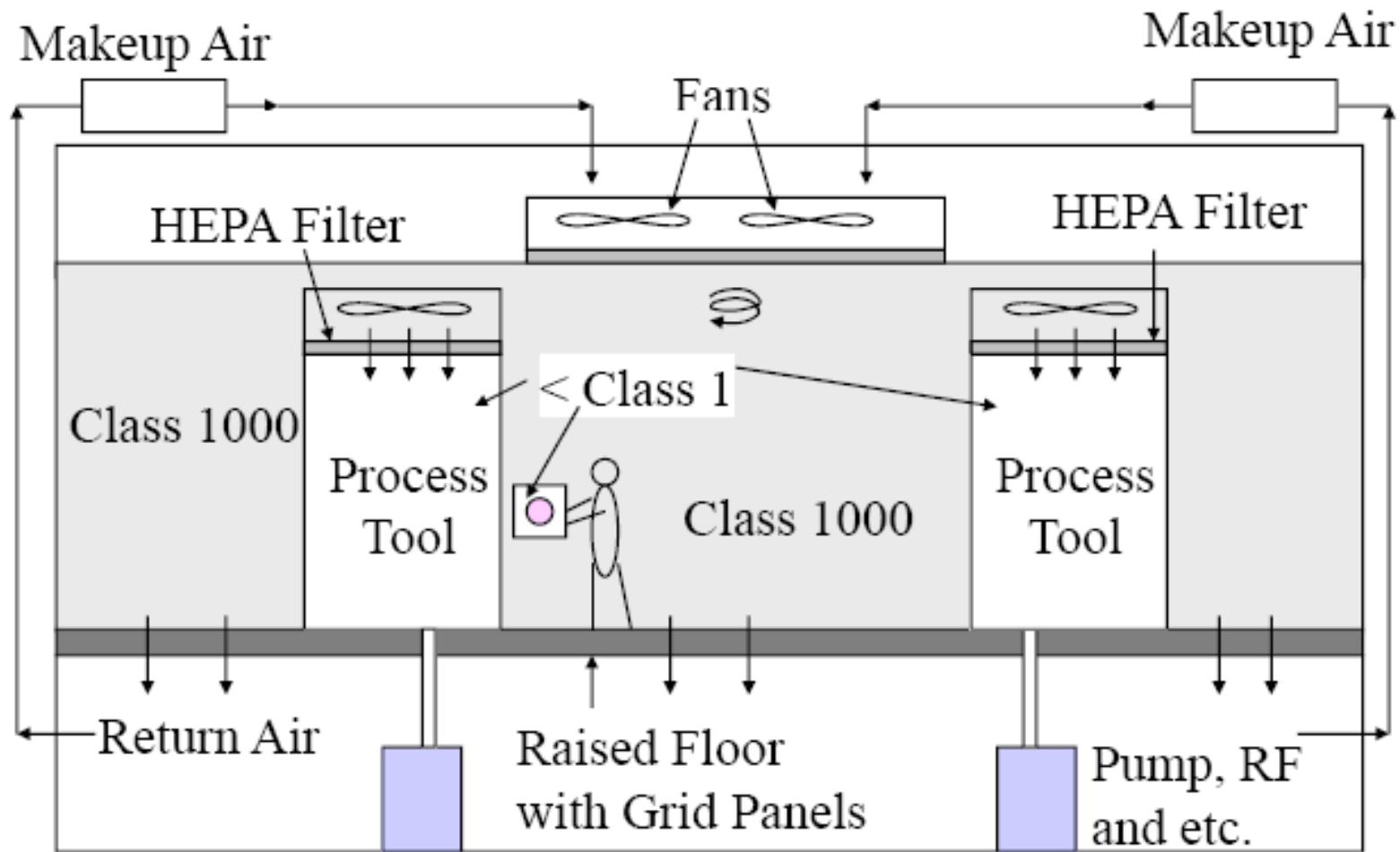



無塵實驗室與生產工廠



實現微/奈米元件的場所

無塵實驗室與生產工廠





Silicon Wafers

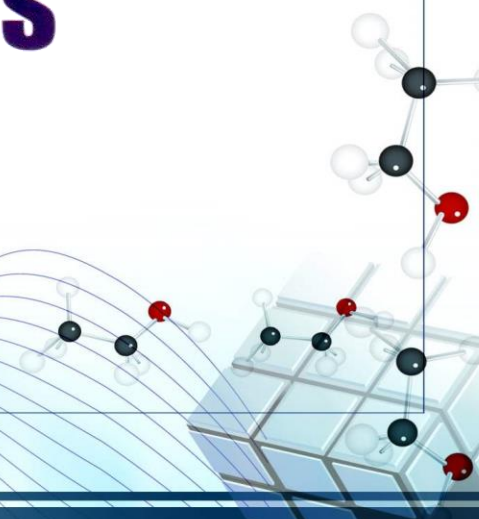
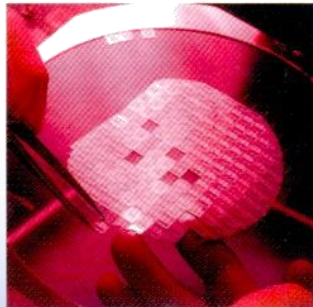



Silicon Wafers (1) — Why Silicon?

- **Abundant, inexpensive**
 - **Thermal stability**
 - **Silicon dioxide is a strong dielectric and relatively easy to form**
 - **Silicon dioxide can be used as diffusion doping and etch mask**
- 

Silicon Wafers (2) — Unit Cell of Single Crystal Silicon

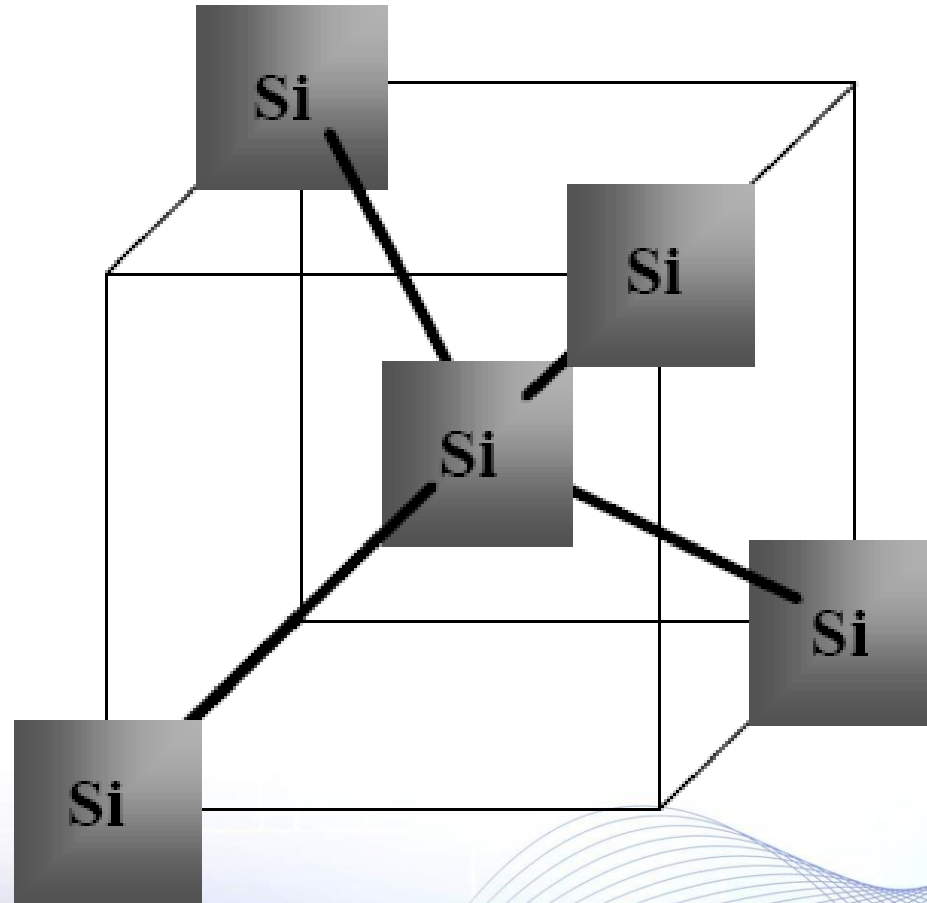

Crystal Orientations: $\langle 100 \rangle$

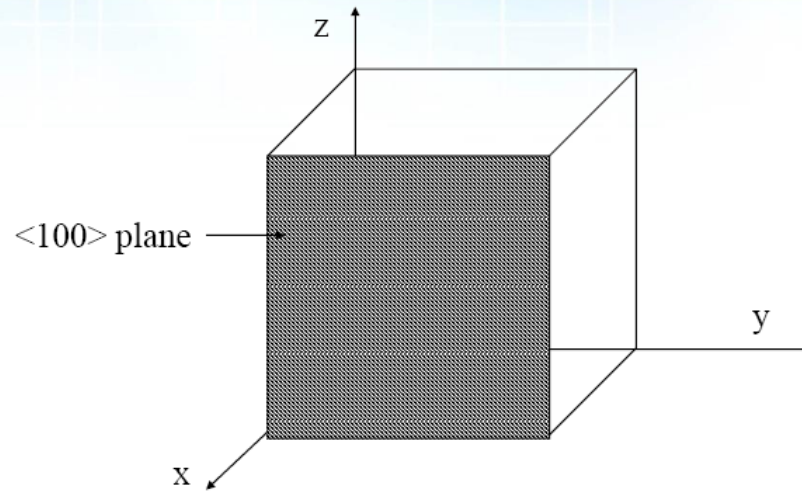

Crystal Orientations: $\langle 111 \rangle$

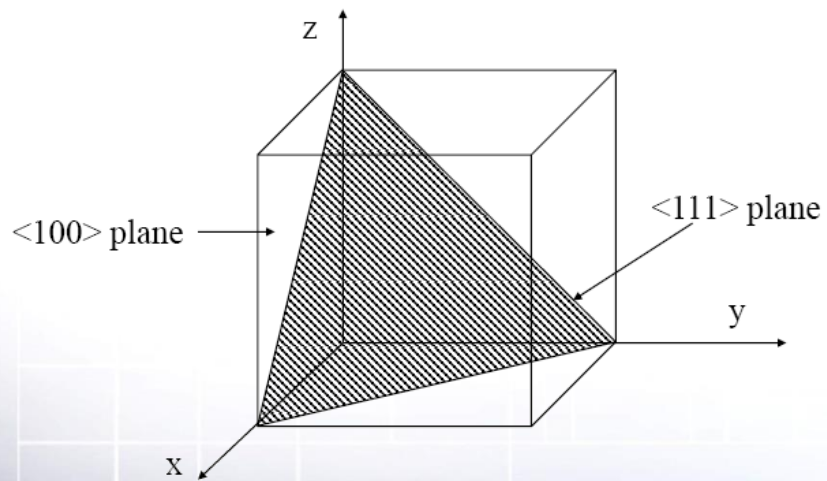

Crystal Orientations: $\langle 110 \rangle$

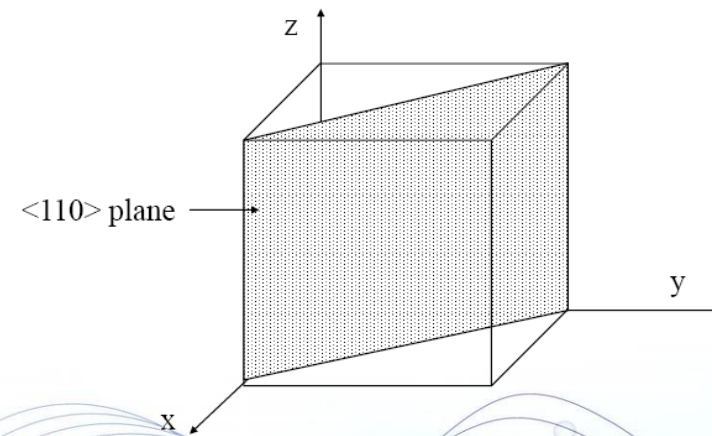

$\langle 100 \rangle$ Orientation Plane

Basic lattice cell

Atom

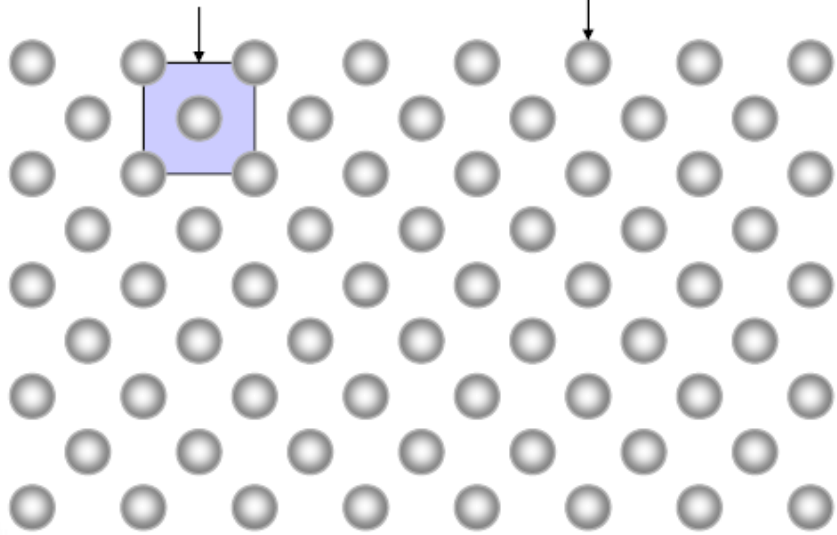

$\langle 100 \rangle$ Wafer Etch Pits

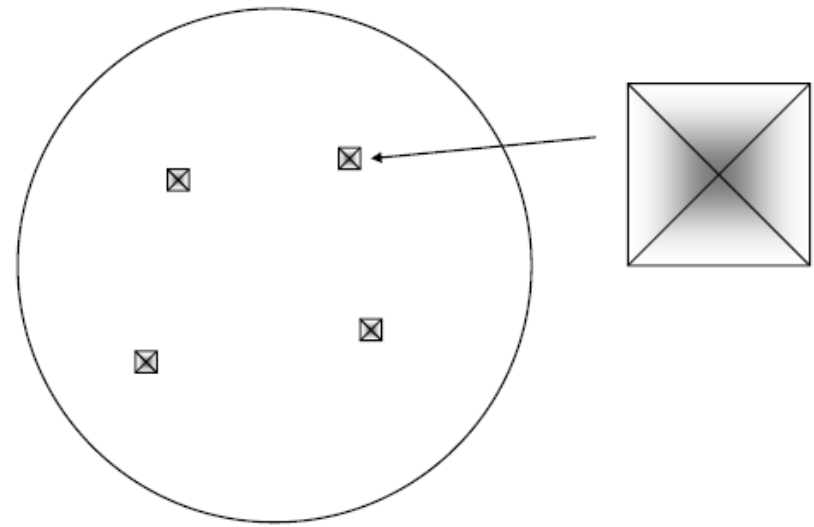

$\langle 111 \rangle$ Orientation Plane

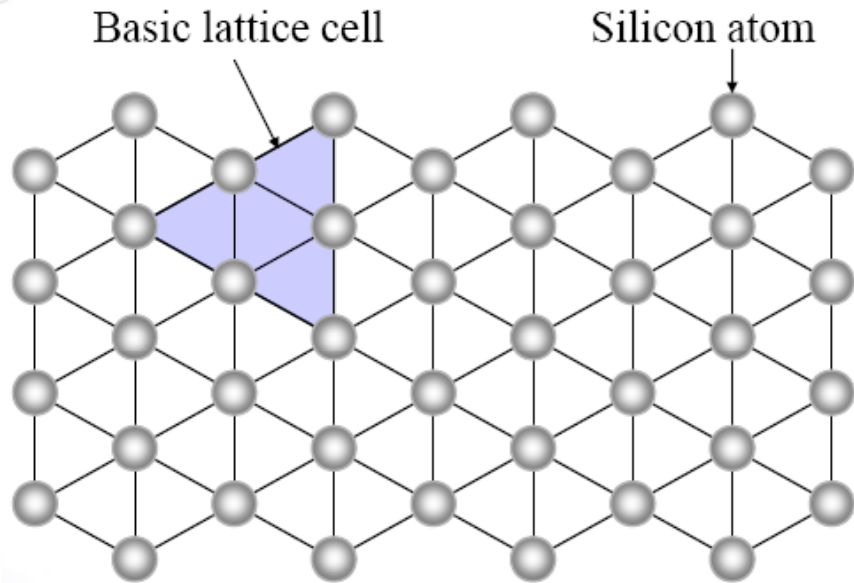

$\langle 111 \rangle$ Wafer Etch Pits

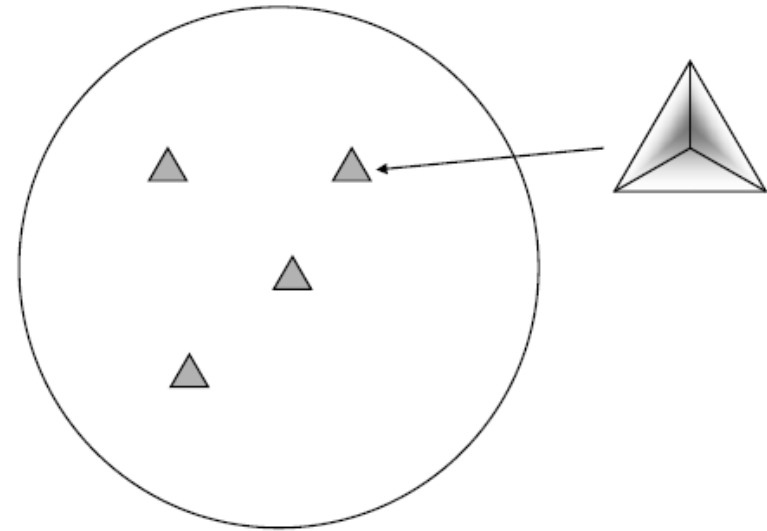

Silicon Wafers (3) — CZ (Czochralski) method

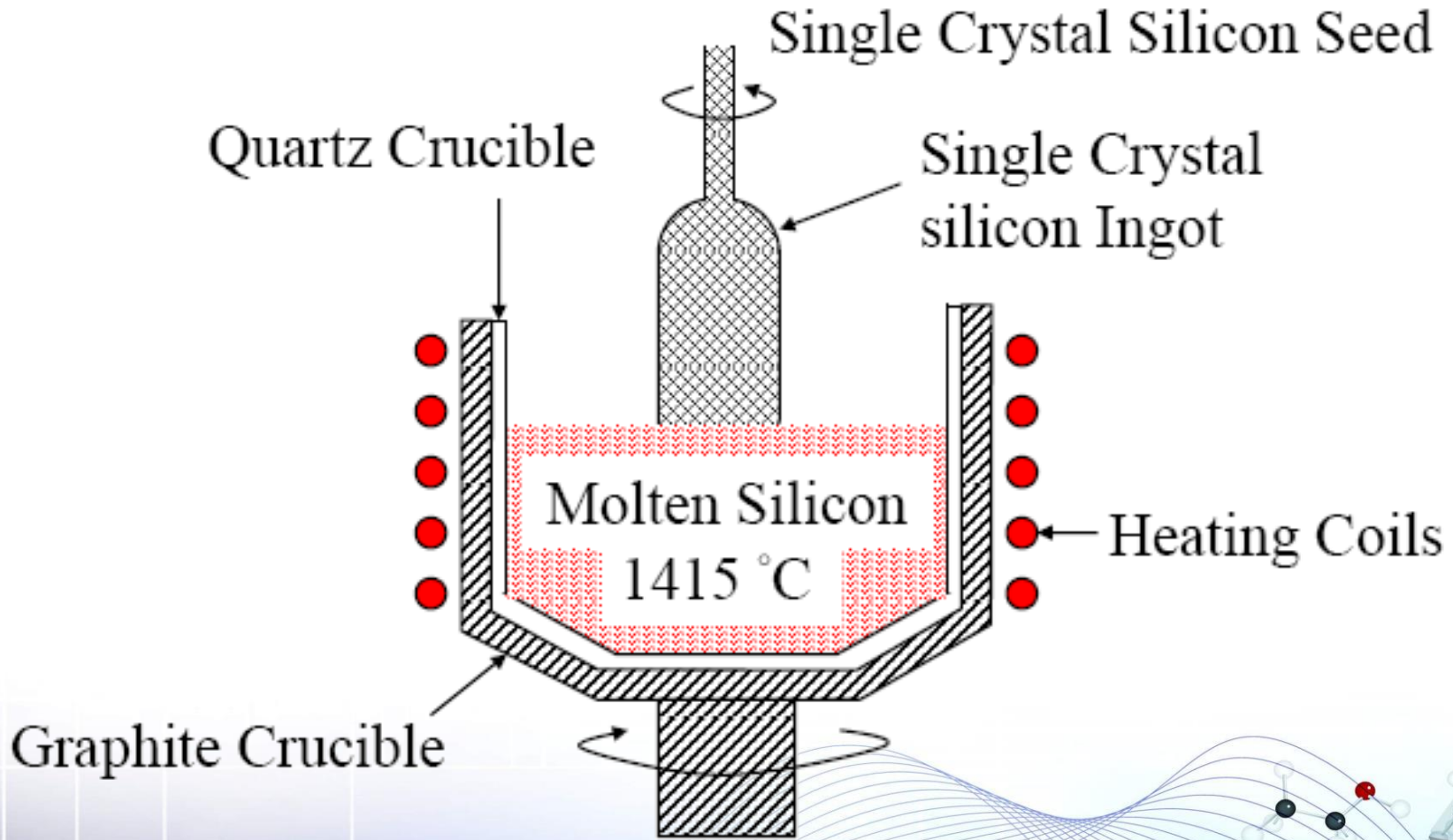



Photograph courtesy of Kayex Corp., 300 mm Si crystal puller

Photo 4.2

CZ Crystal Pulling

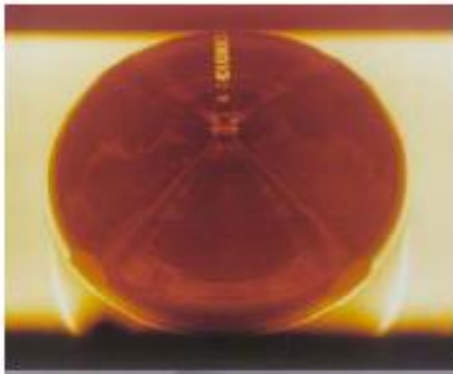
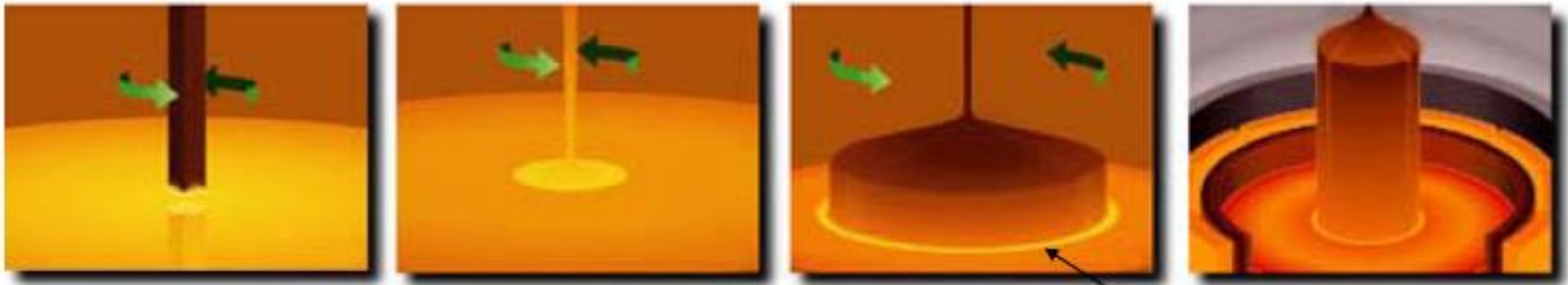

Automatic Diameter Control

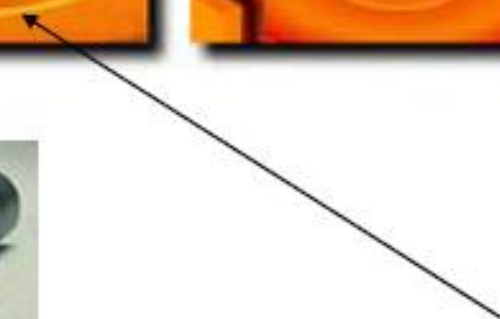

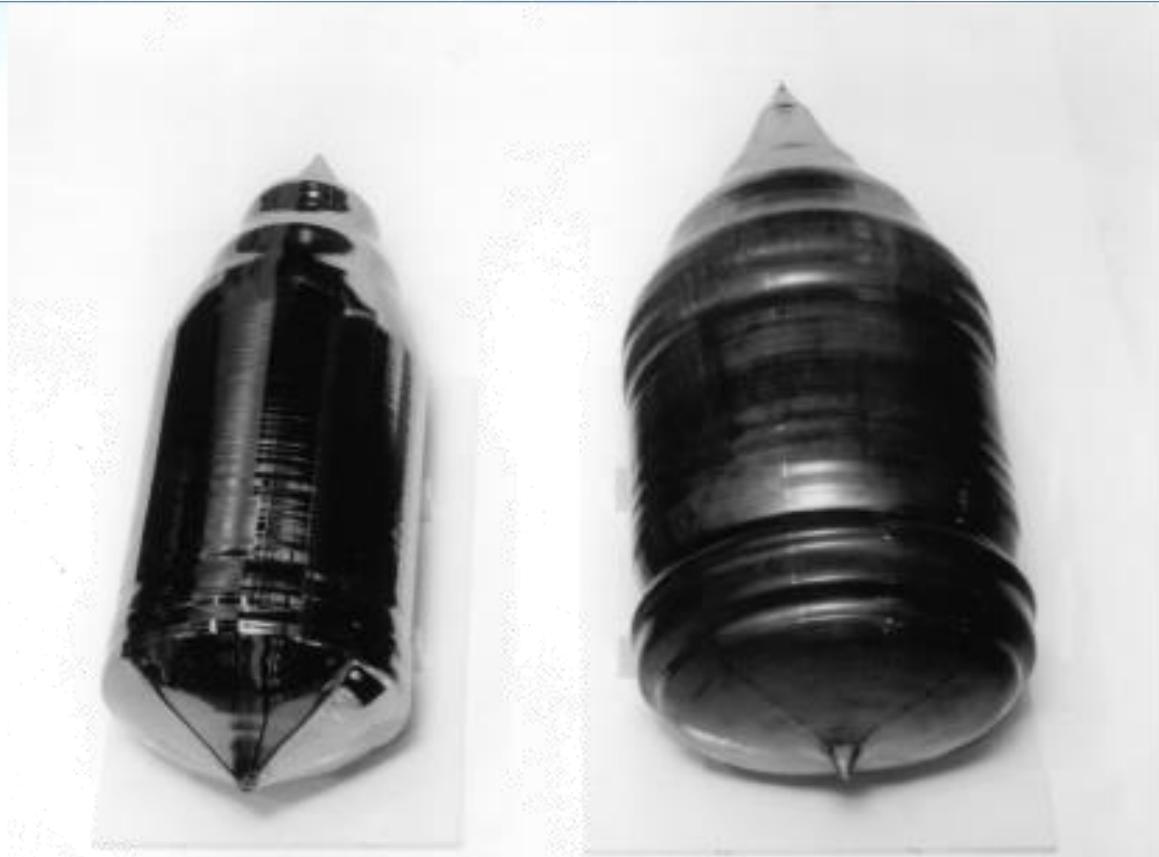

300-mm (12 in.) and 400 mm (16 in.) Czochralski-grown silicon ingots. (Photo courtesy of Sin-Etsu Handotai Co., Tokyo.)

Ingot Polishing, Flat, or Notch

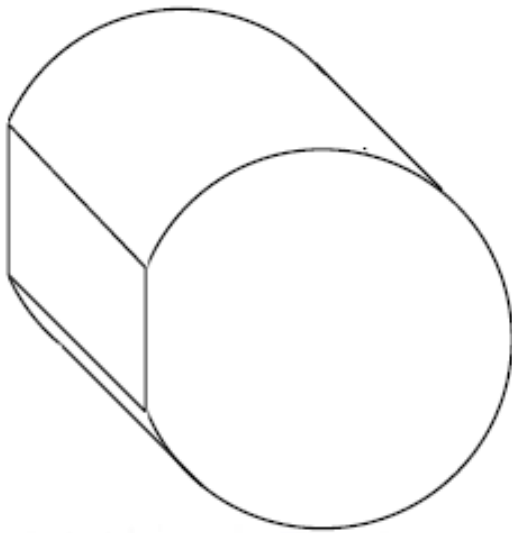

Flat, 150 mm and smaller

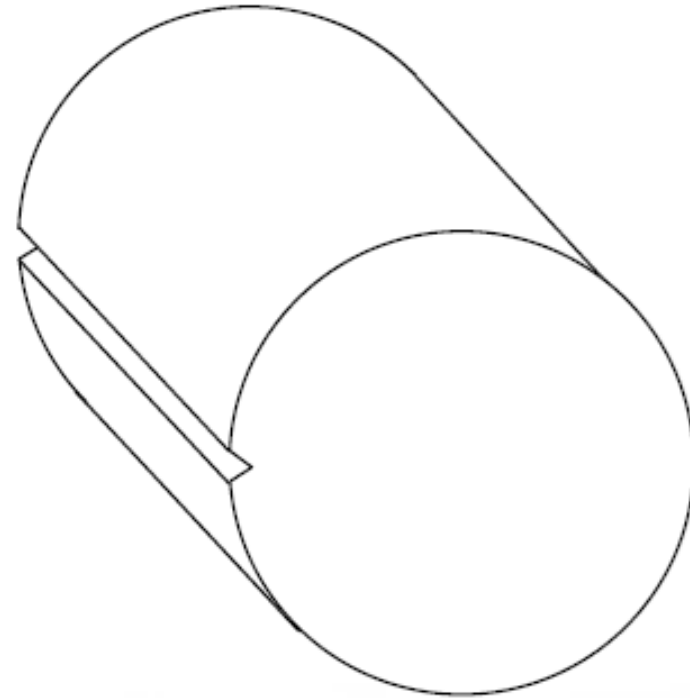

Notch, 200 mm and larger

Wafer Sawing

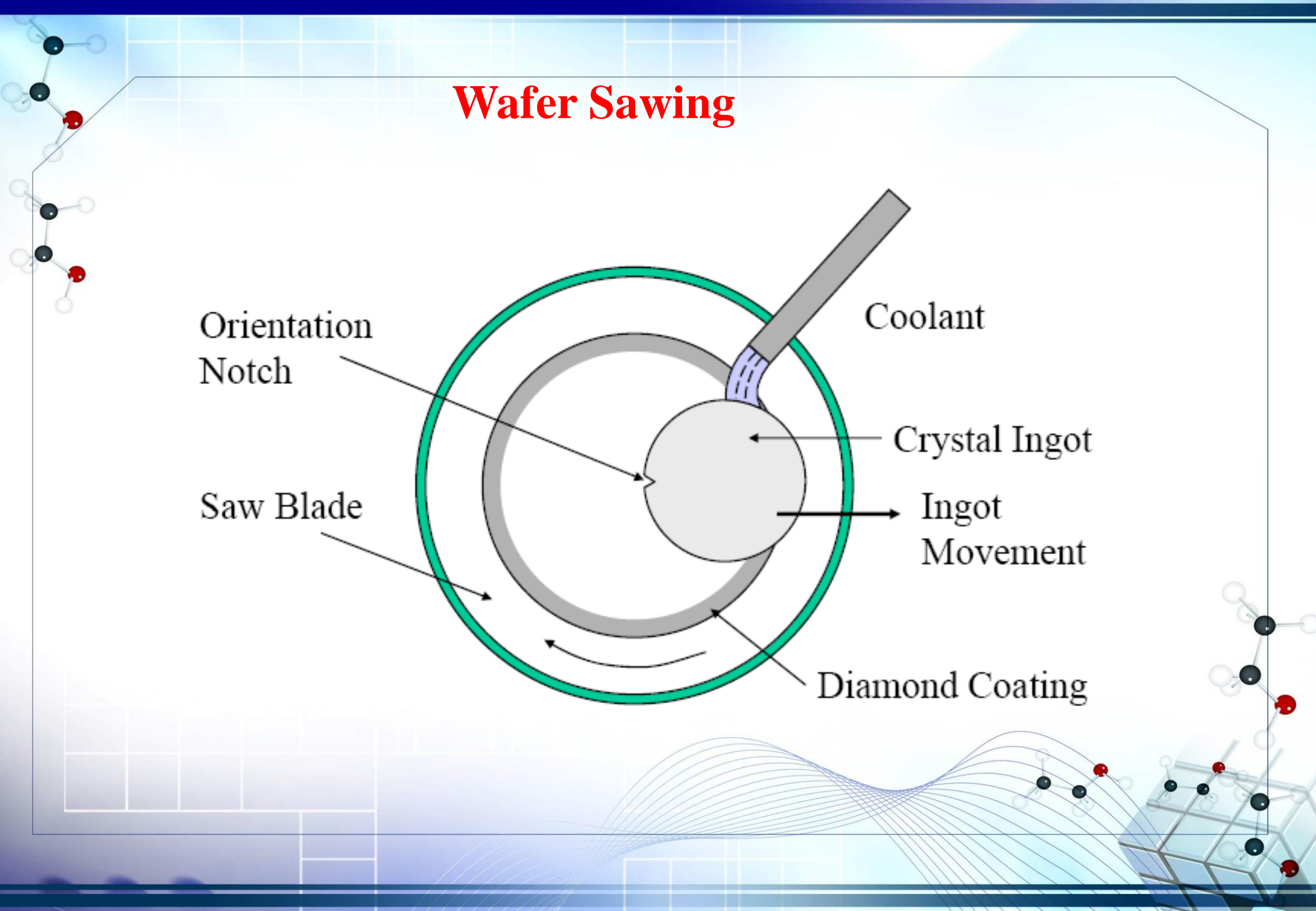
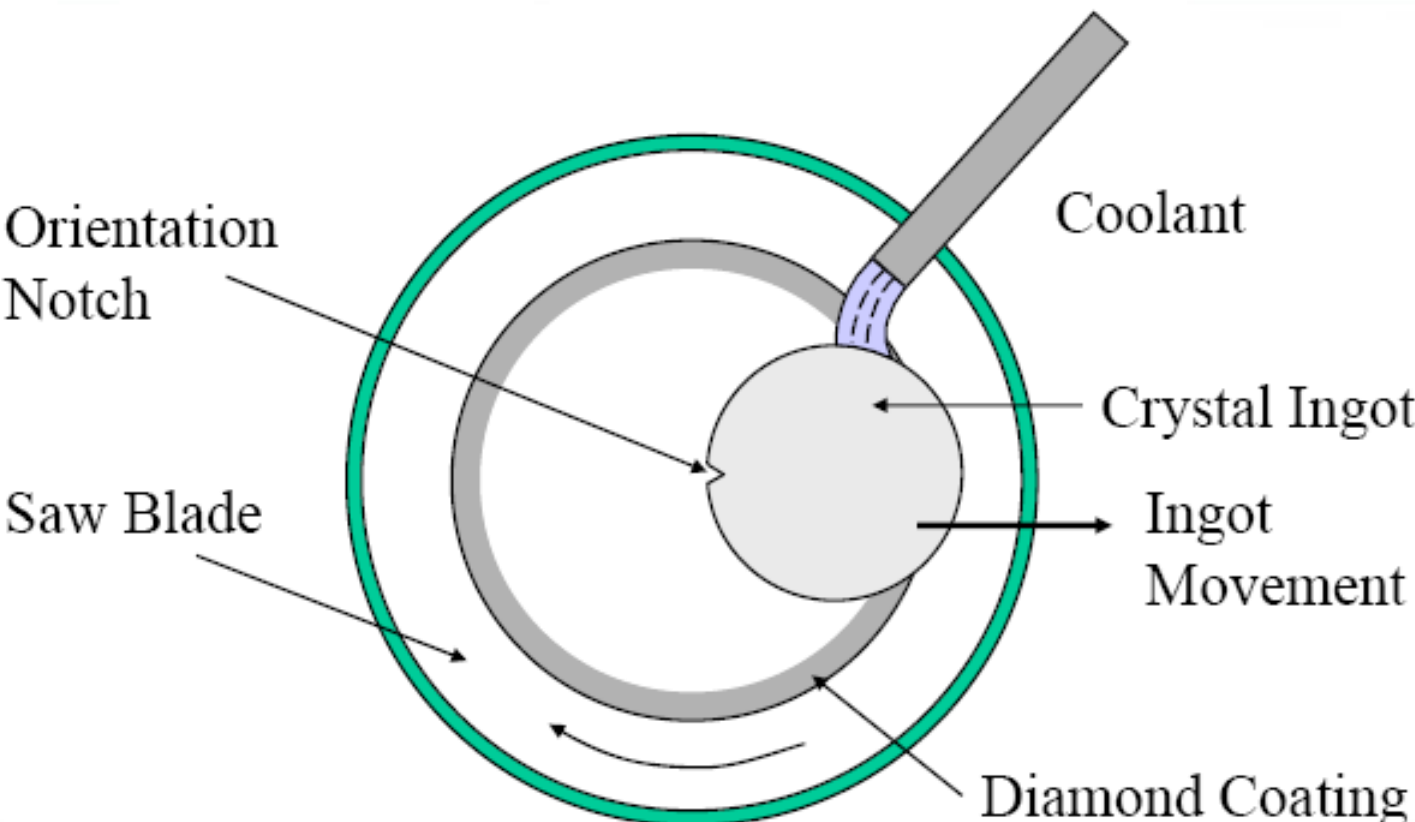

Wafer Edge Rounding

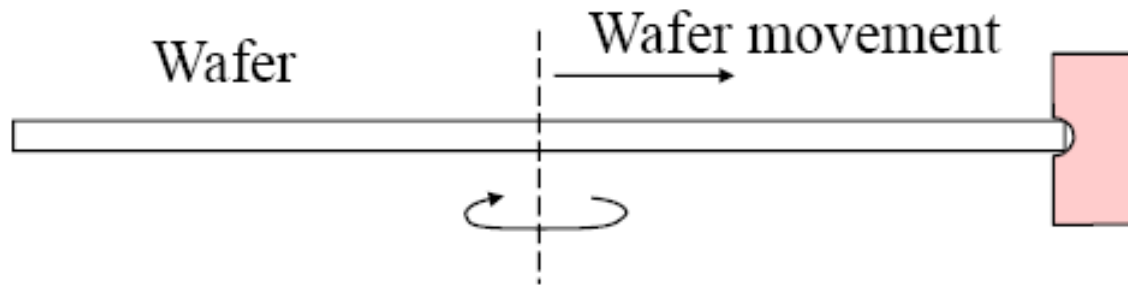

Wafer Before Edge Rounding



Wafer After Edge Rounding

Wafer Lapping

- Rough polished
- conventional, abrasive, slurry-lapping
- To remove majority of surface damage
- To create a flat surface

Wet Etch

- Remove defects from wafer surface
- 4:1:3 mixture of HNO₃ (79 wt% in H₂O),
- HF (49 wt% in H₂O), and pure CH₃COOH.
- Chemical reaction:
- $3 \text{ Si} + 4 \text{ HNO}_3 + 6 \text{ HF} \rightarrow 3 \text{ H}_2\text{SiF}_6 + 4 \text{ NO} + 8 \text{ H}_2\text{O}$

Chemical Mechanical Polishing

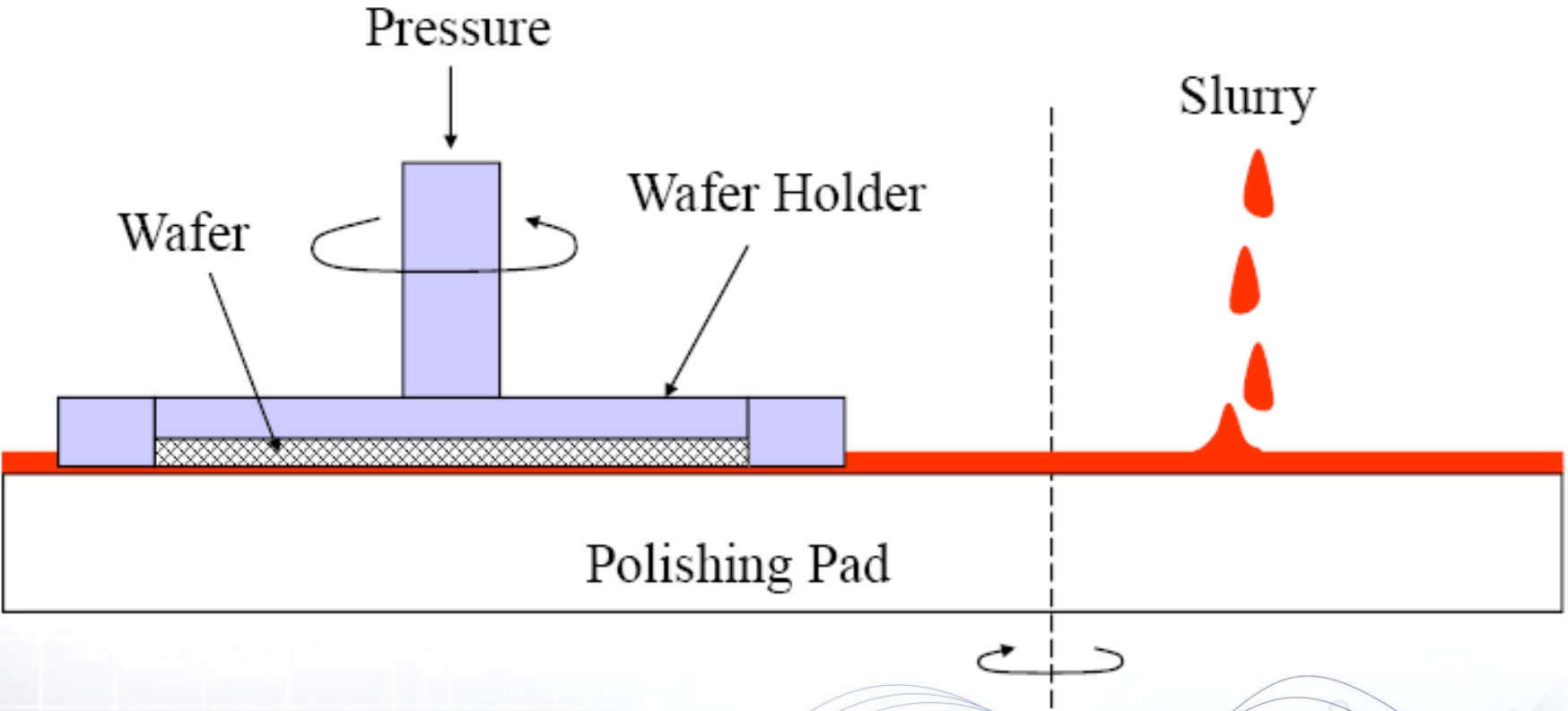

200 mm Wafer Thickness and Surface Roughness Changes

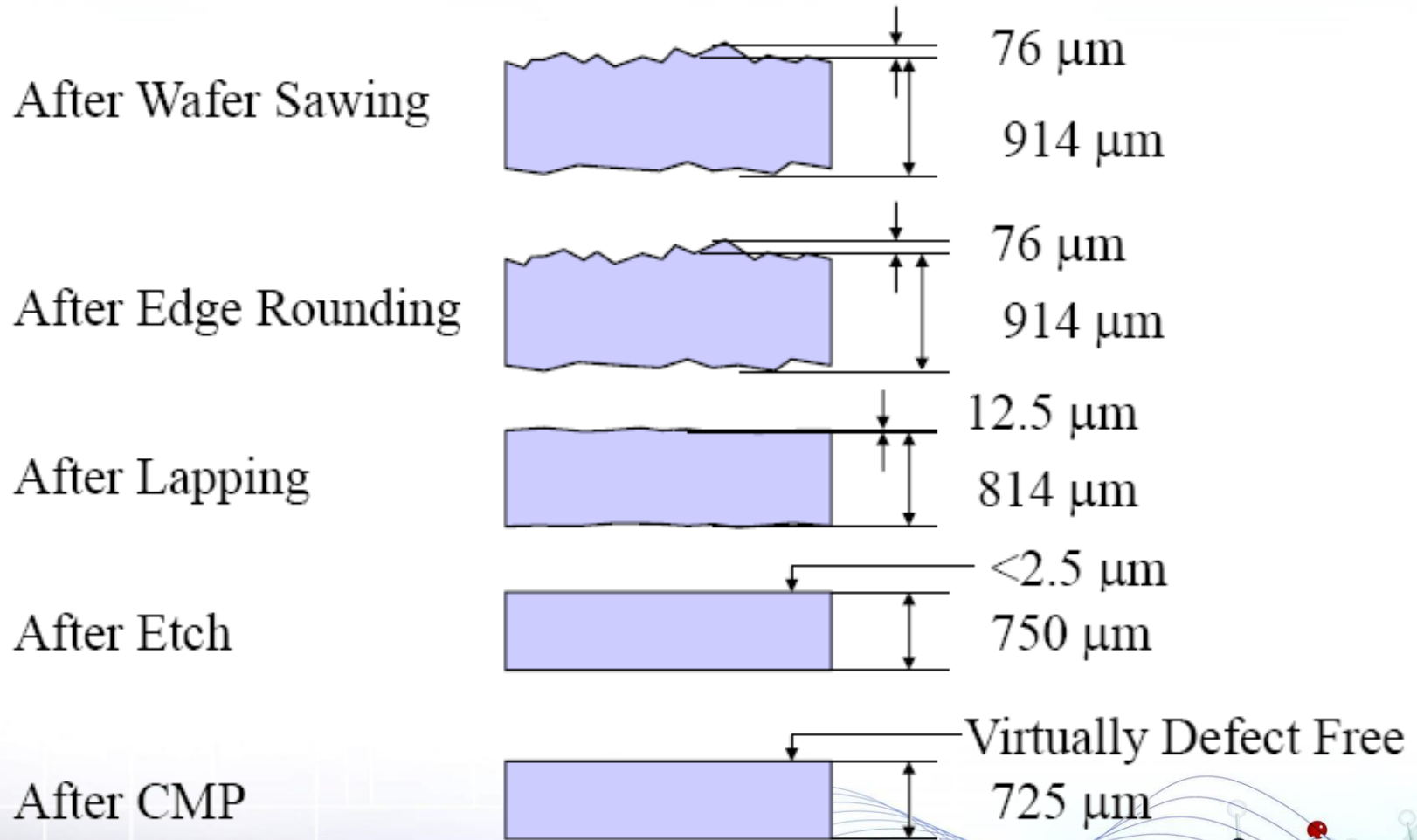



200-mm (8 in.) and 400-mm (16 in.) polished silicon wafers in cassettes.

Basic Process Steps for Wafer Preparation

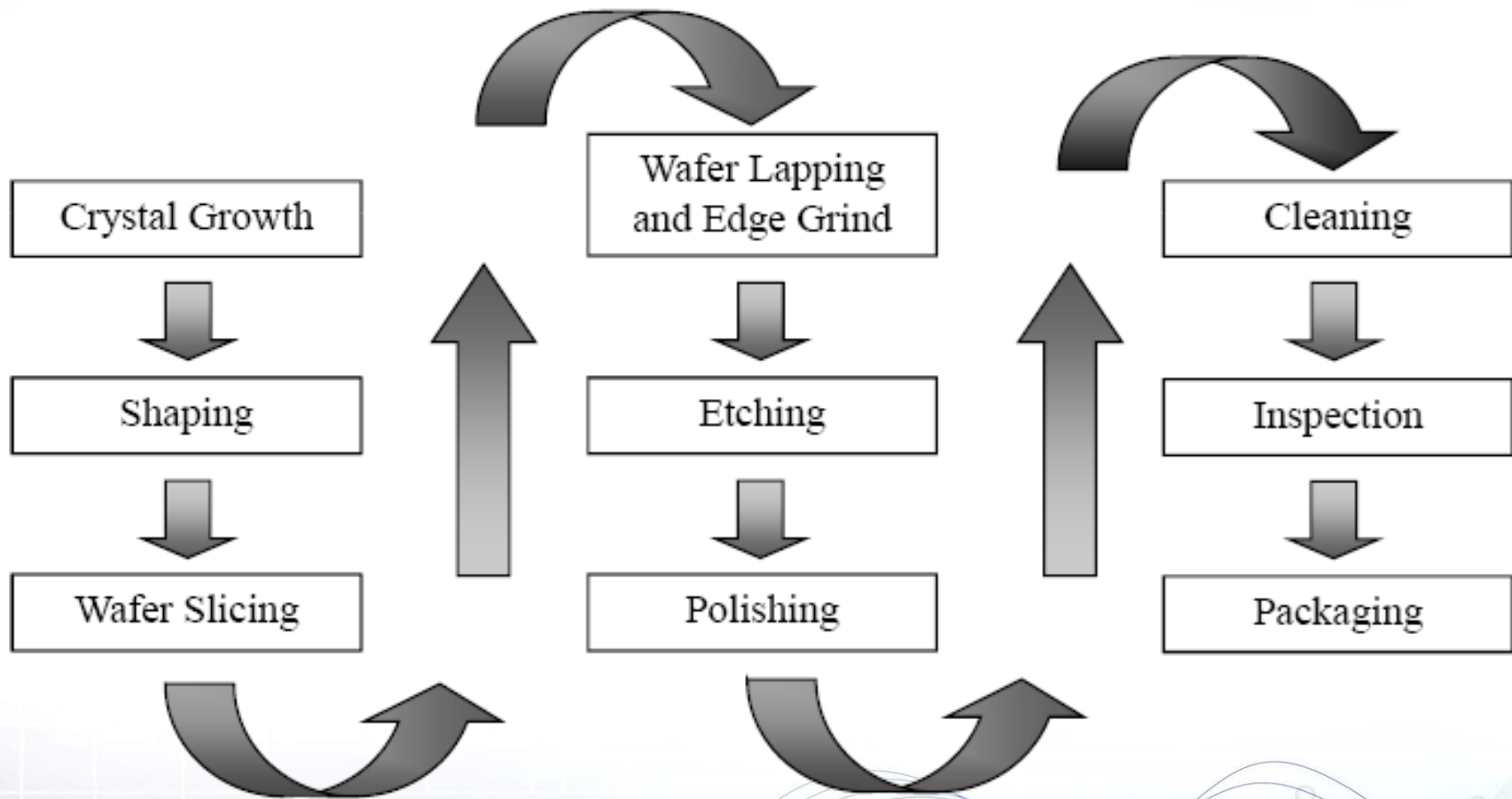

Silicon Wafers (4) — SiO_2 on Silicon Wafer

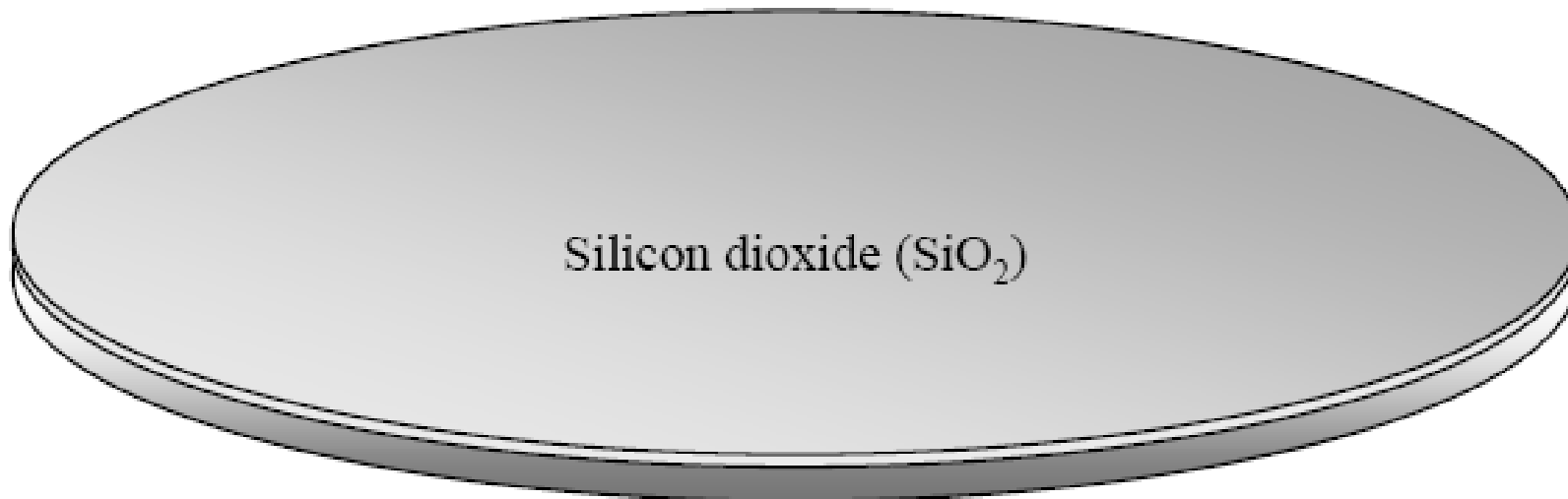

Silicon dioxide (SiO_2)

Silicon wafer

Silicon Wafers (5) — N-type Doped Silicon

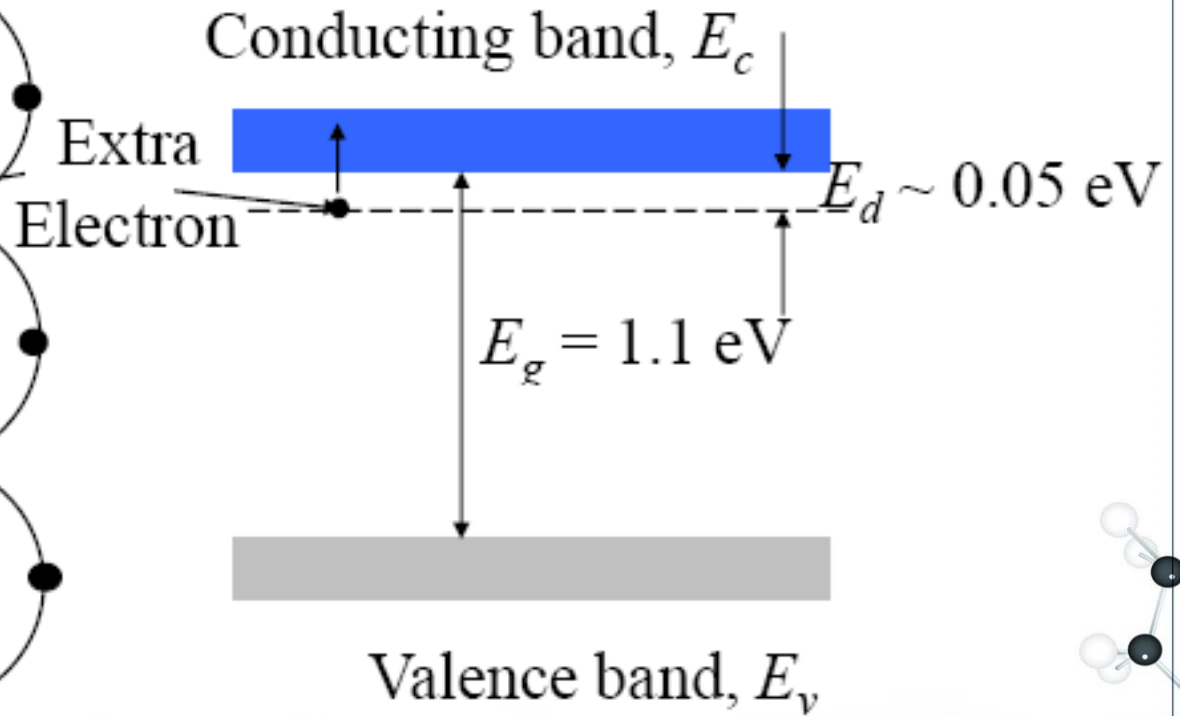
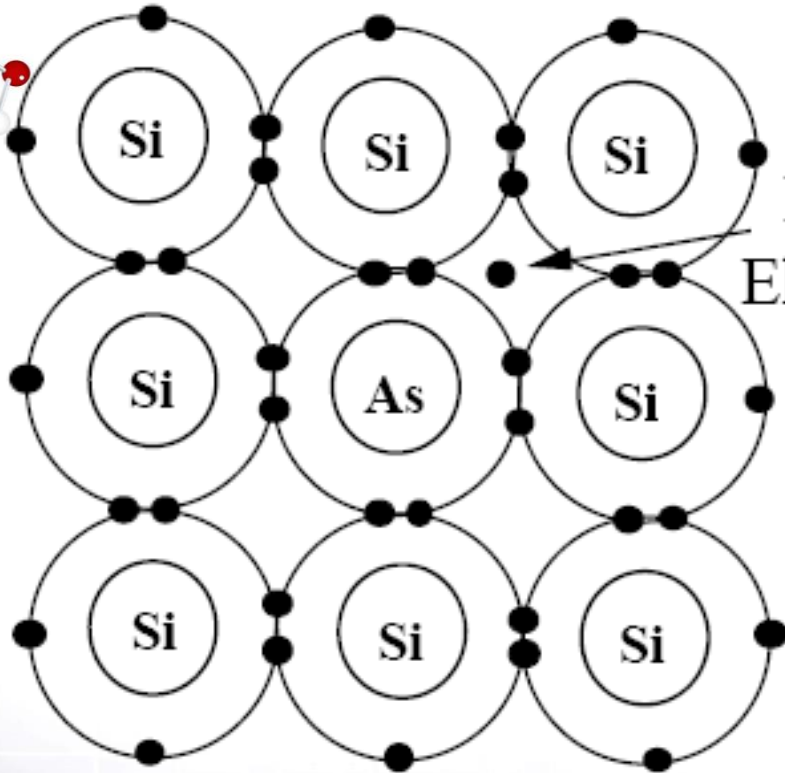

Silicon Wafers (6) — P-type Doped Silicon

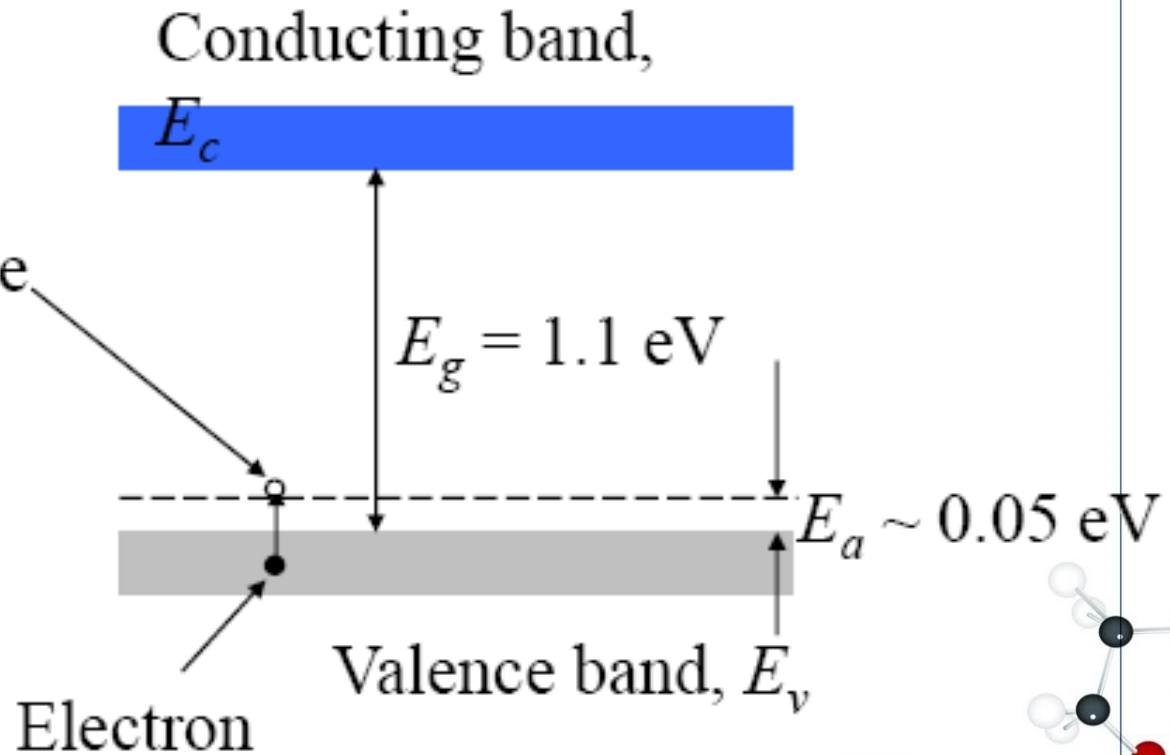
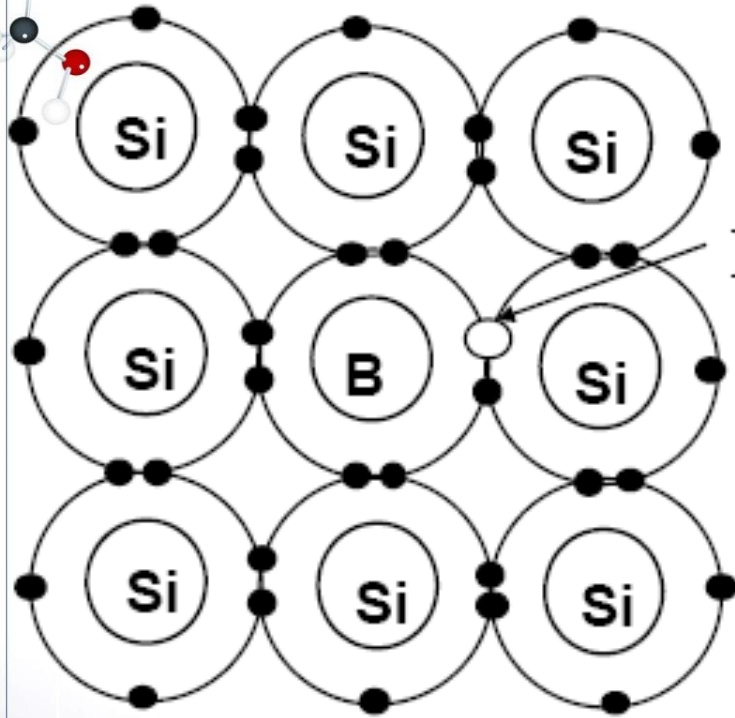

Silicon Wafers (7) — Doping of Silicon

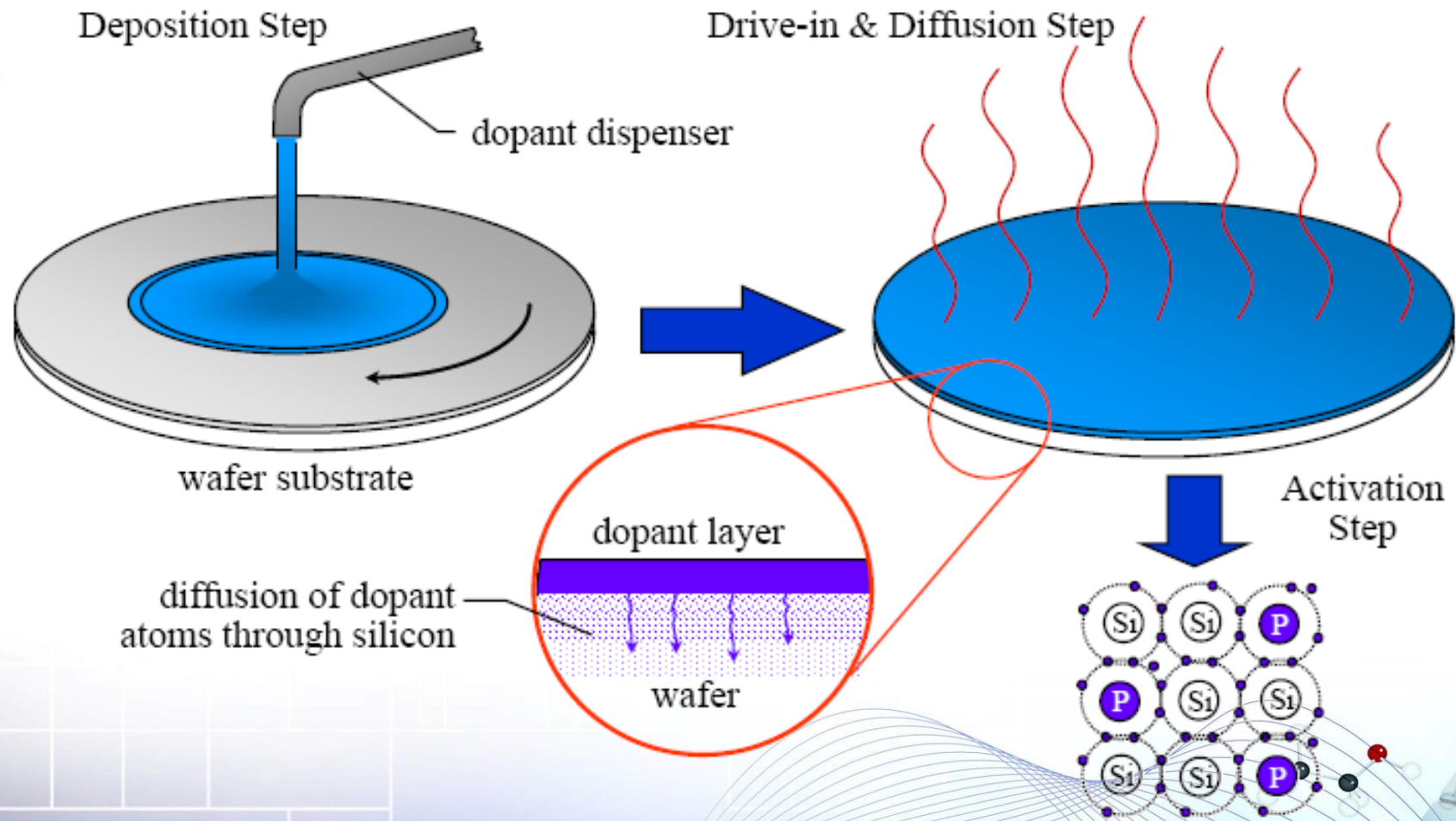

N- and P- Doped

- Increase the conductivity of the semiconductor with impurity
- N- (As, P): donate electrons
 - As^+ , P^+
 - Majority carrier : electron
 - Minority carrier : hole

負摻雜(摻入的五族元素稱為施體)

- P- (B)
 - B^-
 - Majority carrier : hole
 - Minority carrier : electron

正摻雜(摻入的三族元素稱為受體)

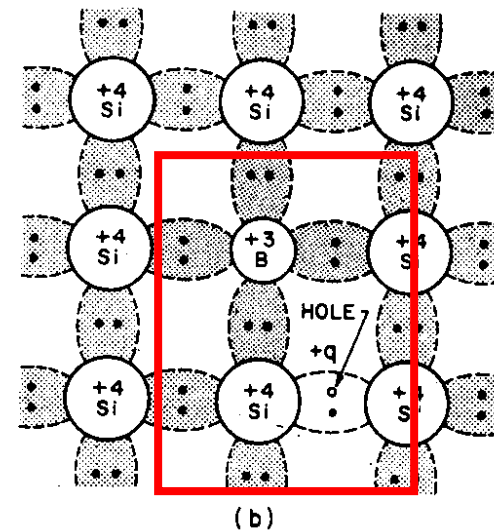
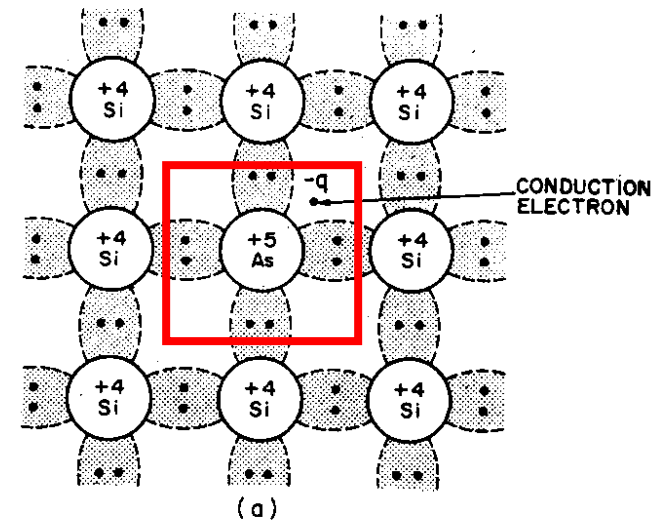

掺雜磷

掺雜硼

n-Type (100)

p-Type (100)

Secondary flat may be here (180°)

Primary flat (110) plane

Primary flat (110) plane

Secondary flat

135°

90°

Secondary flat

n-Type (111)

p-Type (111)

Primary flat (110) plane

Primary flat (110) plane

Secondary flat

45°

Illustration of coded "flats" as typically used on 4 in. wafer to help identify them (SEMI standard).

Silicon Wafers (8) — 矽晶圓的規格

矽晶圓規格：

4" Silicon Wafer

Type/Dopant: P/Boron P type, 摻雜硼

Orientation: (100)

Diameter: 100+/-0.5 mm

Growth Method: CZ CZ長晶方法

Thickness: 525+/-25 um

Resistivity: 20-50 ohm-cm

Particle: <=30 @ 0.3 um

Front/Back surface: polished/etched

TTV: <=10 um 晶圓最大及最小的厚度差

Bow/Warp: <=50 um 彎曲度/撓曲度

Grade: TEST 晶圓為Test等級

註：矽晶圓必須由硬殼包裝盒裝載

4" Si wafer

Type/Dopant: P/Boron

Orientation: (110)

Resistivity: 1-10 ohm-cm

Thickness: 500-550 um

Surface: Polished/Etched

Grade: Prime 晶圓為Prime等級

2 Semi-Std Flats on the (111) Plane

Photolithography



Standard RCA cleaning Process

1. 沖D.I. water 5'。 比例與時間各家會有所差異

去除有機物

2. $\text{H}_2\text{SO}_4:\text{H}_2\text{O}_2=3:1$ 煮10'~20' (75°C~85°C)

3. 沖D.I. water 5'。

去除氧化膜

4. $\text{HF}:\text{H}_2\text{O}=1:100$ 10"~30" (不沾水) SiO_2 會沾水
Si不沾水

5. 沖D.I. water 5'。

去除微粒子與有機物

6. $\text{NH}_4\text{OH}:\text{H}_2\text{O}_2:\text{H}_2\text{O}=0.25:1:5$ 煮10'~20' (75°C~85°C)

7. 沖D.I. water 5'

去除金屬

8. $\text{HCl}:\text{H}_2\text{O}_2:\text{H}_2\text{O}=1:1:6$ 煮10'~20' (75°C~85°C)

9. 沖D.I. water 5'

去除氧化膜

10. $\text{HF}:\text{H}_2\text{O}=1:100$ 10"~30" (不沾水)

11. 沖D.I. water 5'。

12. 用 N_2 dry。或是旋乾(spinning dry)

相當重要！！

※先倒入 H_2O ，再倒入酸或鹼，若有 H_2O_2 則最後倒入。

※含有HF的廢酸，請倒至HF的專用回收槽。

黃光微影製程(定義圖案)

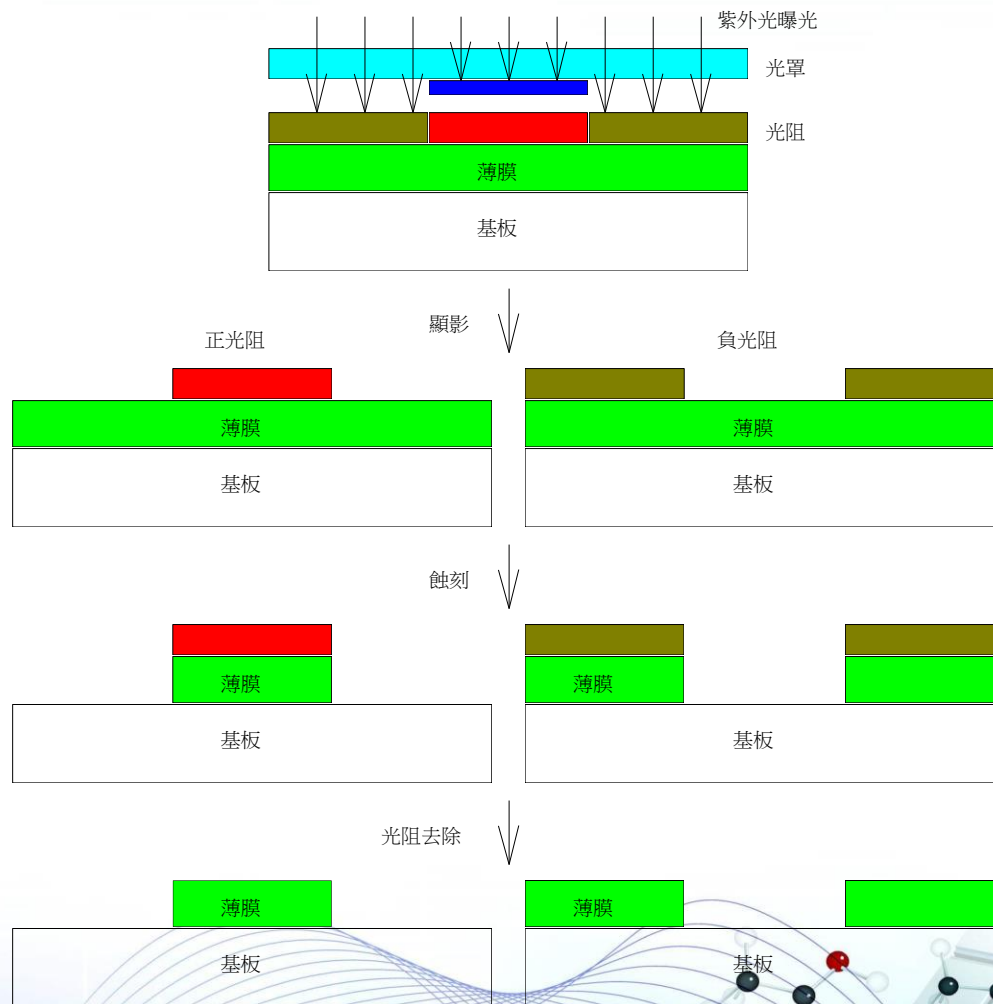
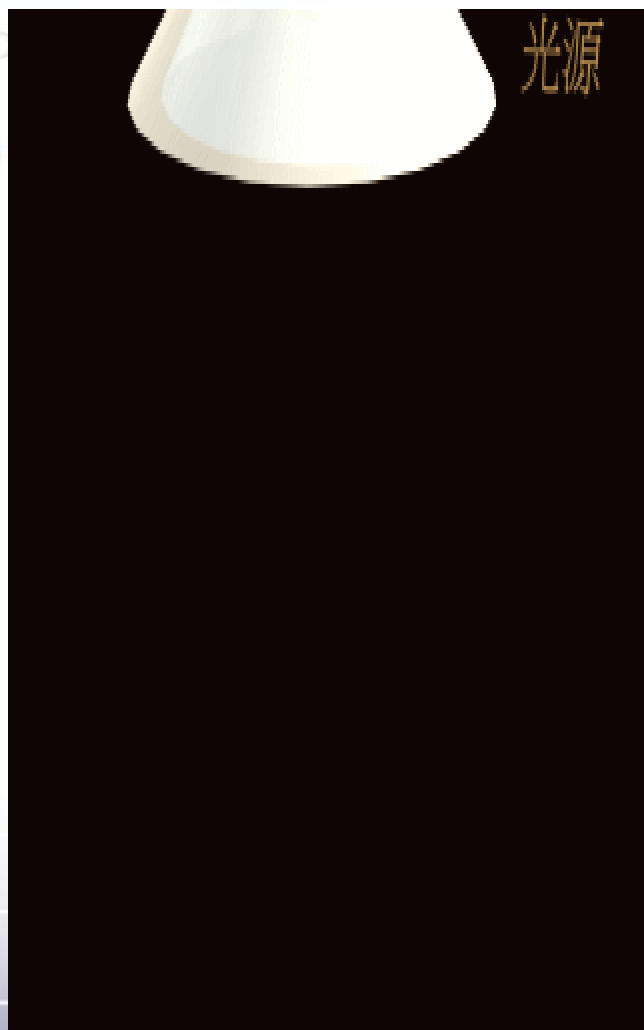

正、負光阻微影製程示意圖

光阻的微影程序

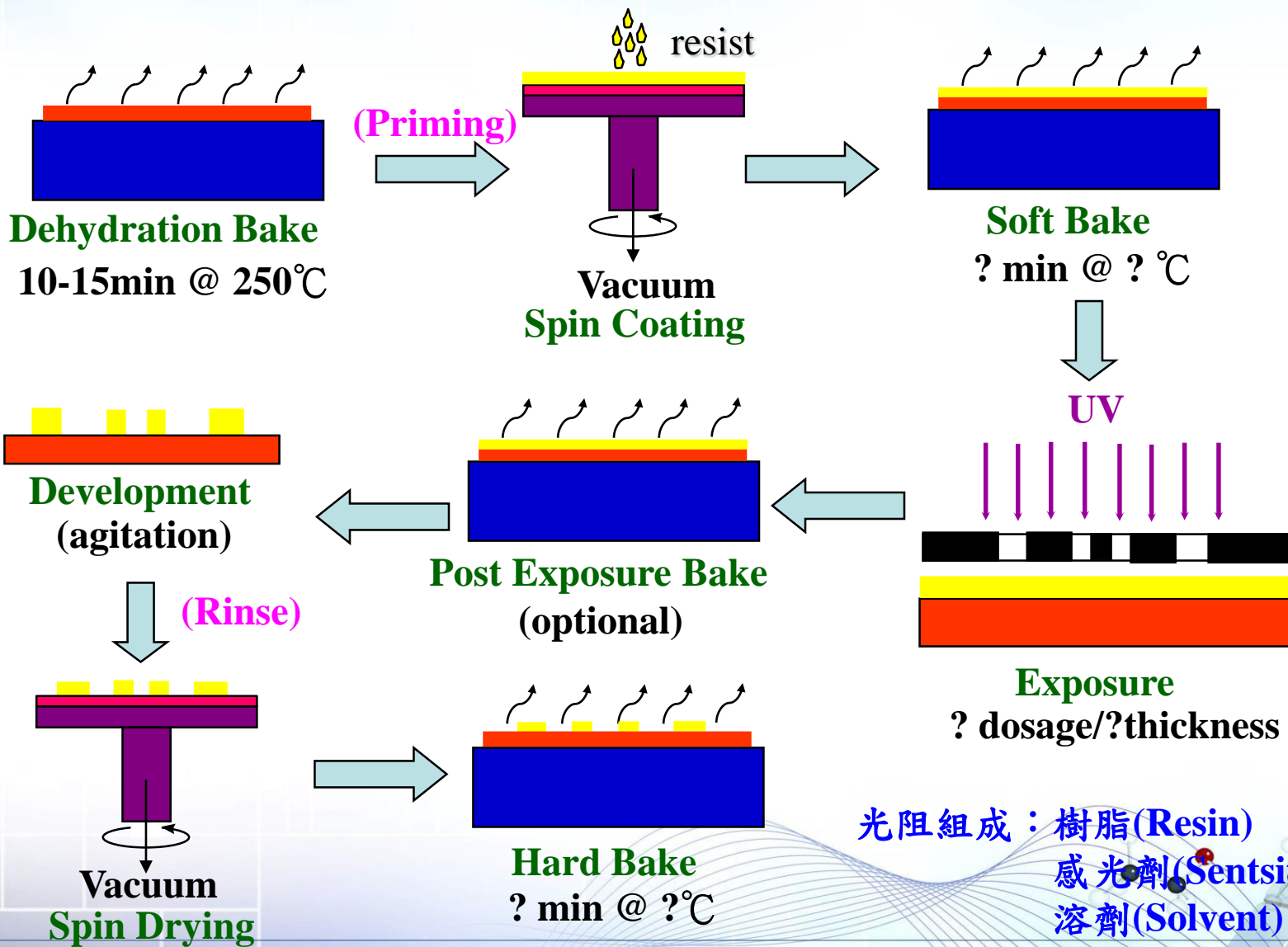

光阻組成：樹脂(Resin)
感光劑(Sensitizer)
溶劑(Solvent)

曝光(exposure)與光罩對準(mask align)

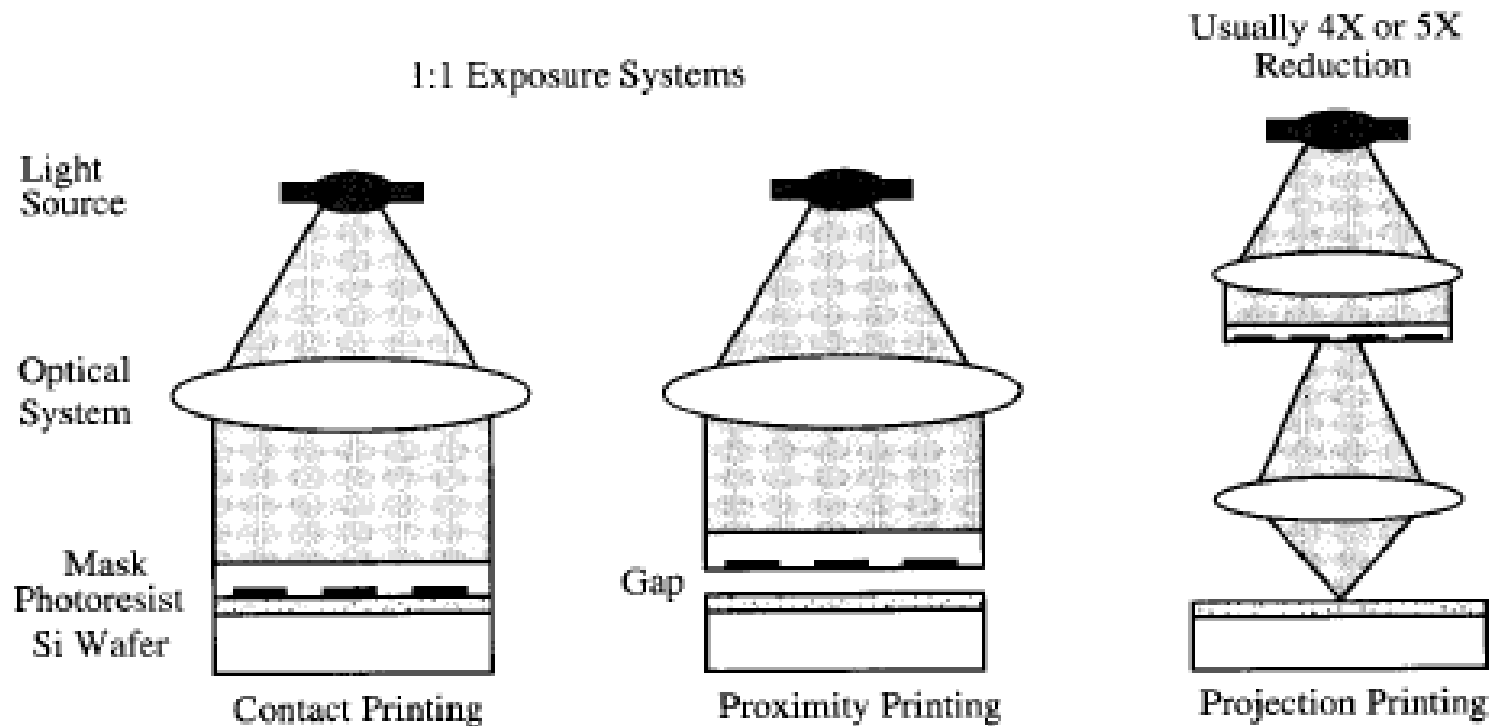

單面光罩對準

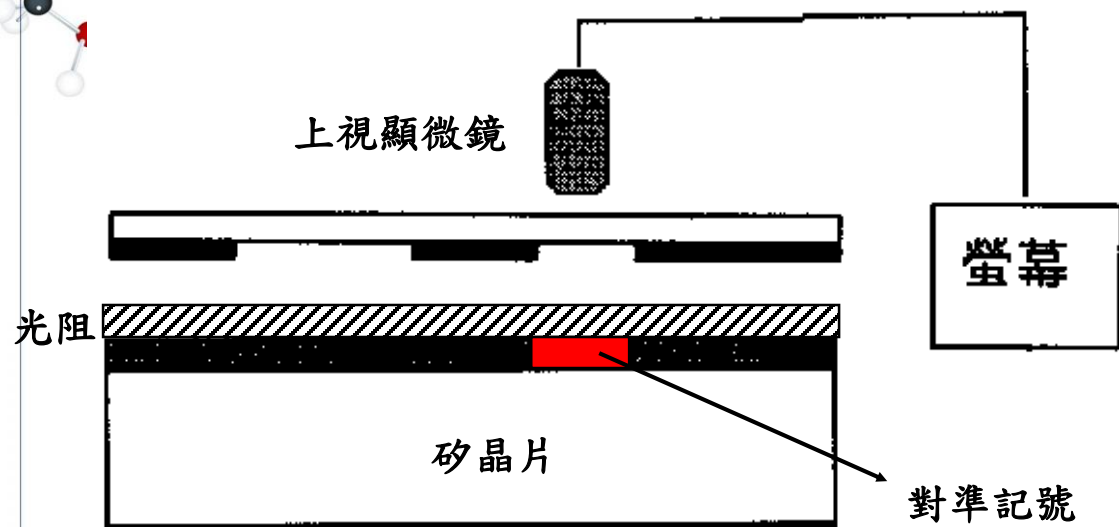

以可見光做單面對準

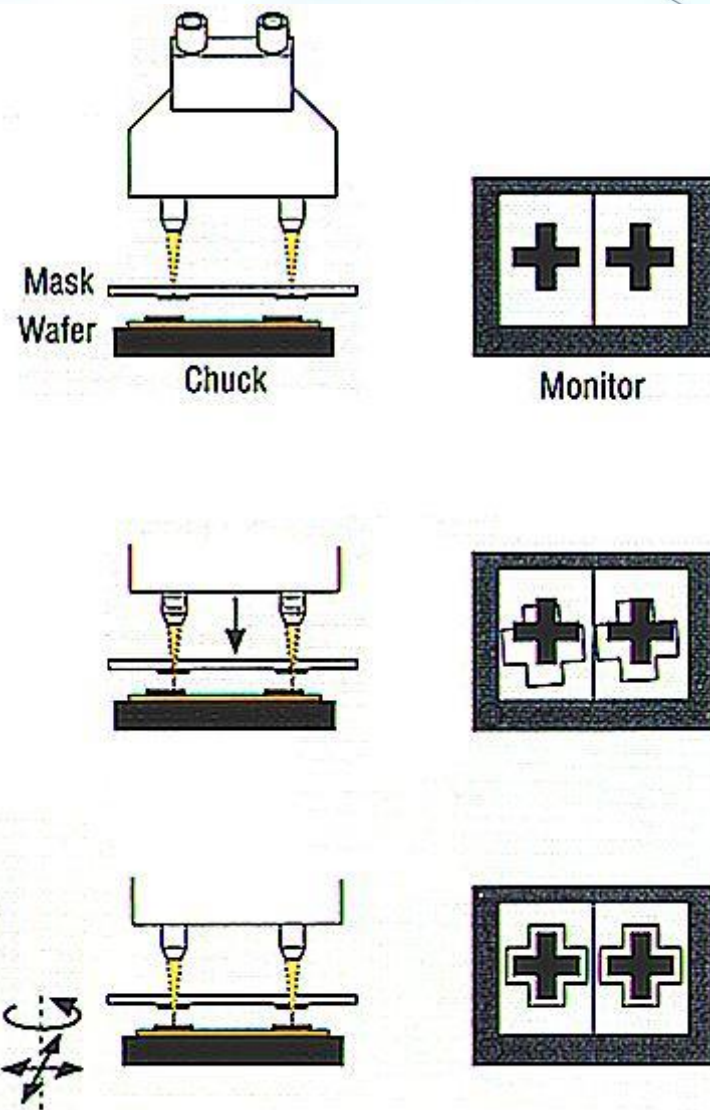

雙面光罩對準

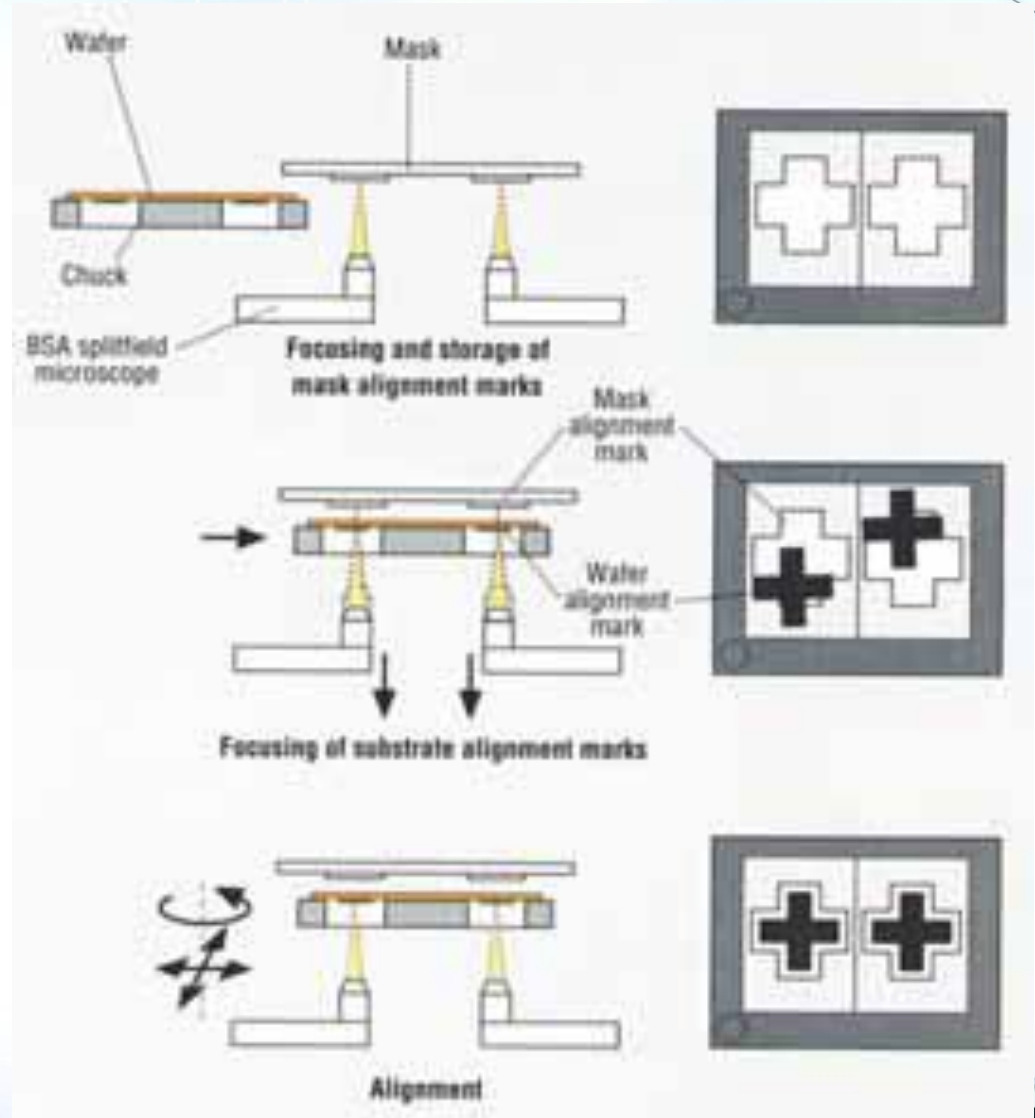
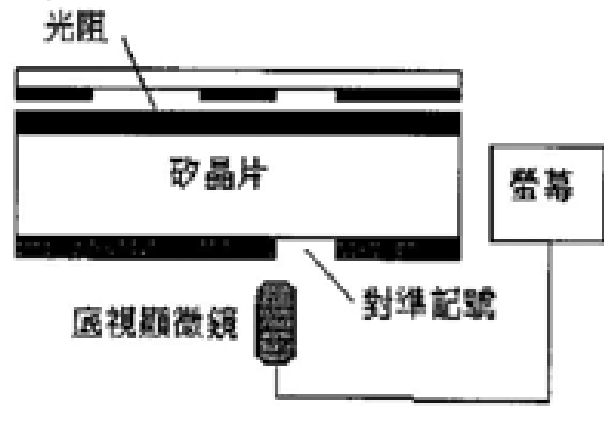
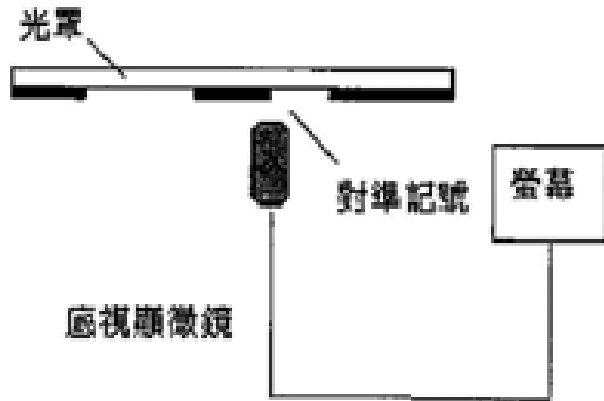

光罩-晶圓對準示意圖

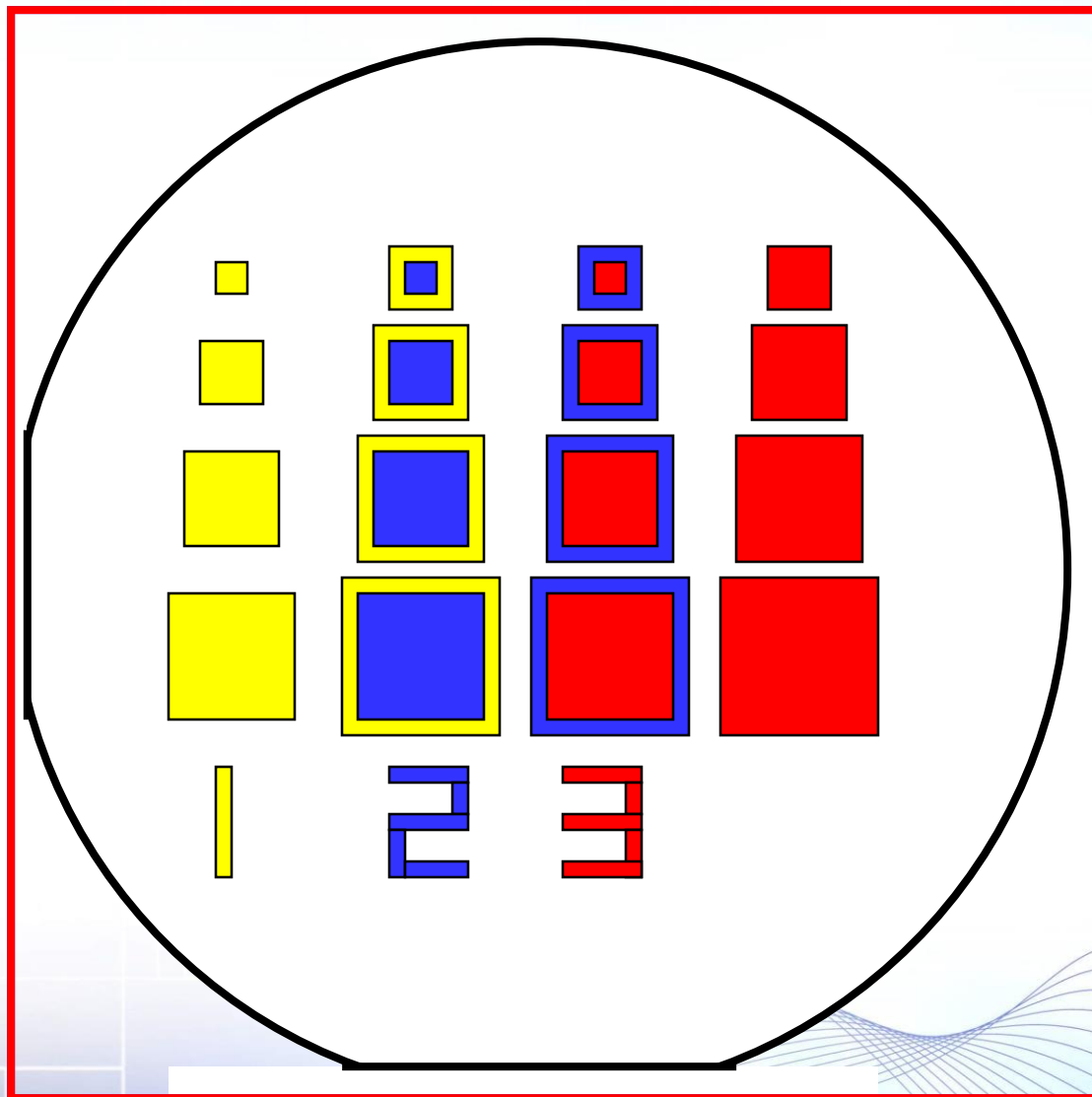

Patterned Wafer

Mask 2

Mask 3

Film Vapor Deposition



真空鍍膜技術之分類

- 化學氣相沉積法 (Chemical Vapor Deposition)
 - 熱CVD (Thermal CVD): LPCVD, APCVD
 - 電漿輔助CVD (Plasma-enhanced CVD)
 - 有機金屬CVD (Metal organic CVD)
- 物理氣相沉積法 (Physical Vapor Deposition)
 - 濺鍍 (Sputtering)
 - 蒸鍍 (Evaporation)

薄膜沈積

Chemical Vapor Deposition (CVD)

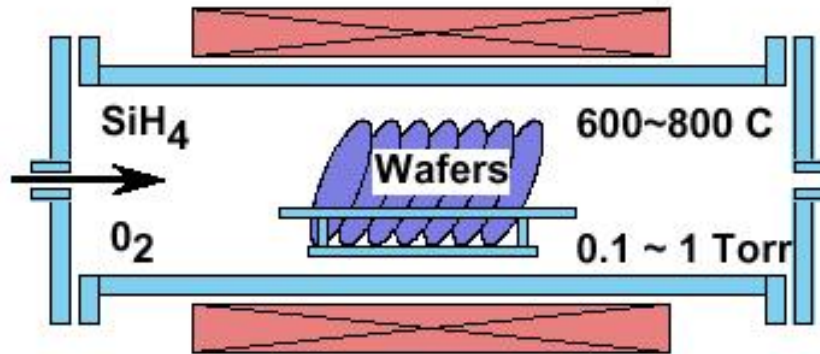

Polysilicon (~ 2 μm)

SiO₂ (~ 2 μm)

PSG (~ 4 μm)

Si₃N₄ (~ 0.3 μm)

Mainly Si related materials

+ stress controllable

+ high density

- high temperature

- PECVD
- LPCVD
- APCVD
- MOCVD

(光電薄膜沈積)

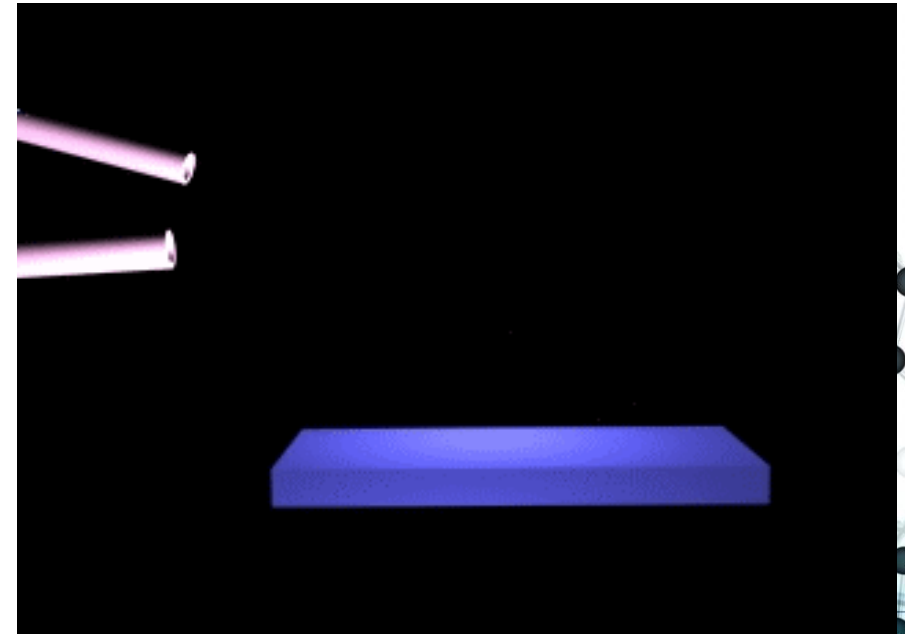

Physical Vapor Deposition (PVD)

Sputtering

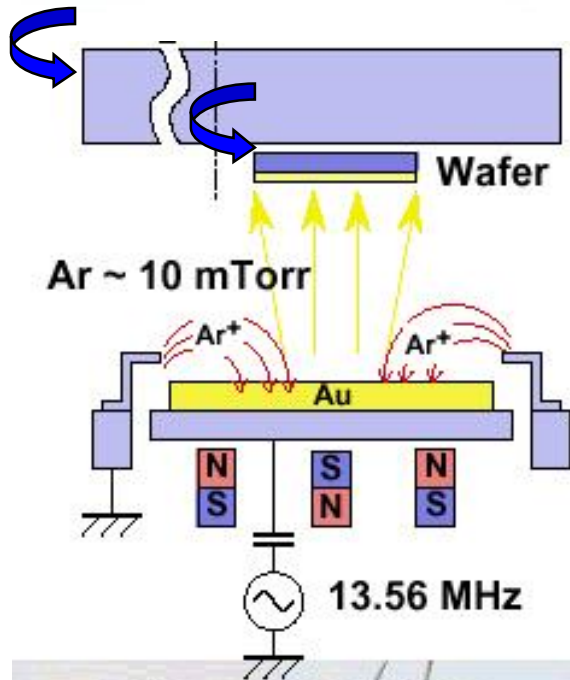

Metal (Cr, Au, Ni, Fe, Ti, Cu, Pt, ...)

Alloy (FeNi, TiNi, ...)

Oxide (SiO₂, Al₂O₃, ...)

Nitride (AlN, SiN, ...)

All in 0.1 ~ 5 μm range

TiN,
TiW

+ various materials other than
oxide or nitride

- residual stress

- less density

Sputtering Process

chamber

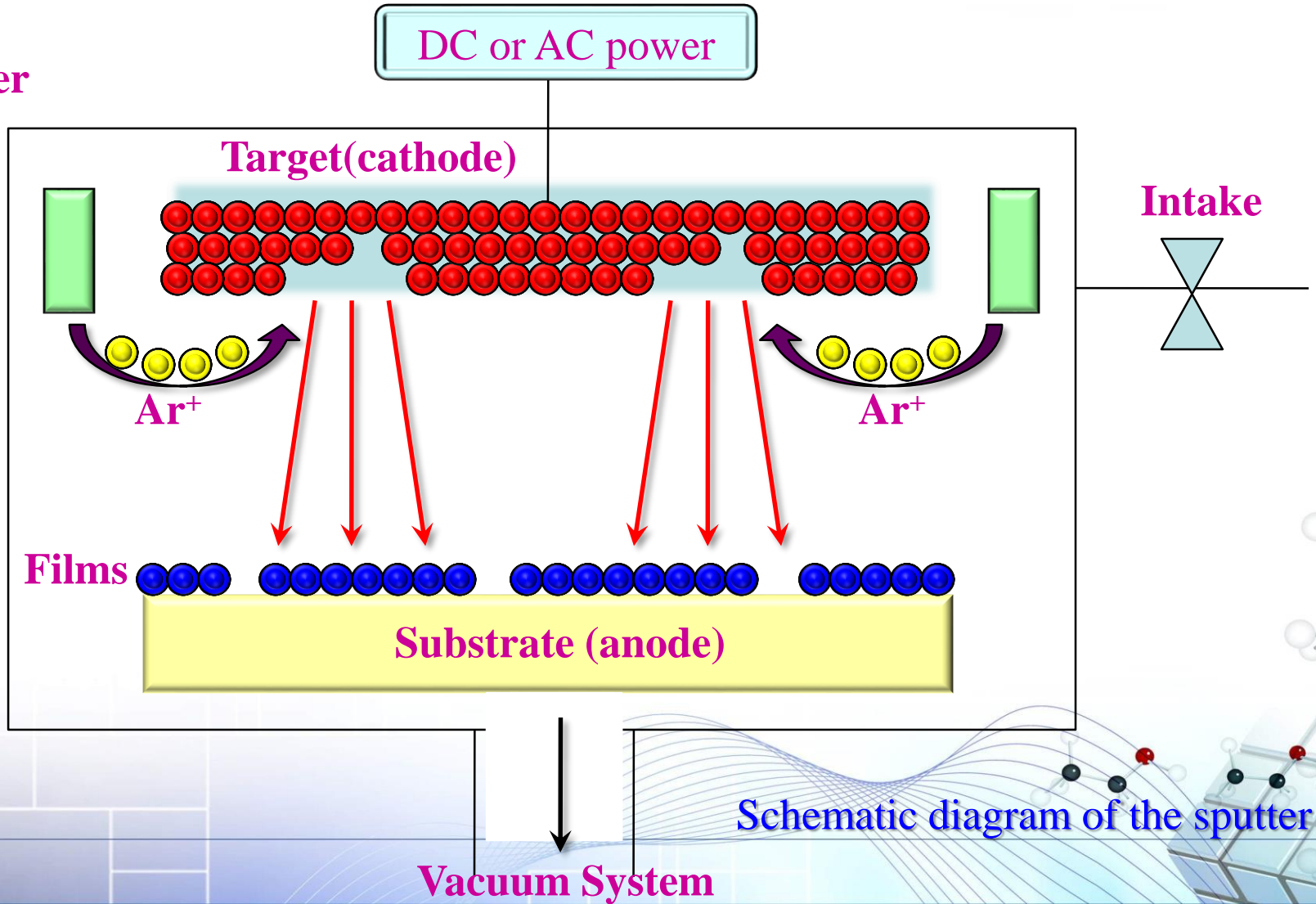

Evaporation (PVD)

(Joule heat or Electron beam)

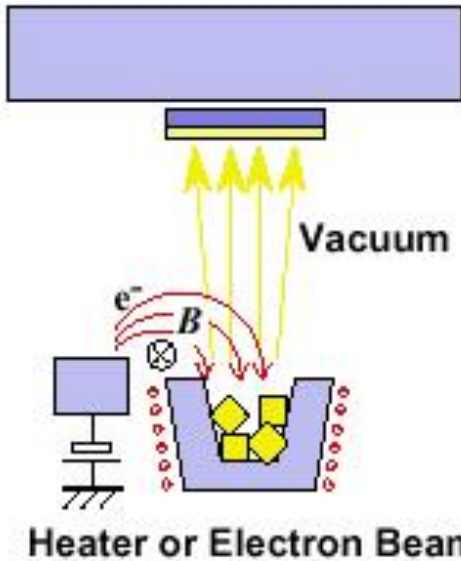

Metal (Cr, Au, Ni, Fe, Ti, Cu, Pt, ...)

Alloy (FeNi, TiNi, SiW, ...)

Oxide (MgO, ...)

Nitride (AlN, SiN, ...)

All in 0.1 ~ 5 μ m range

+ high melting temp. materials

+ density higher than sputtering (EB)

- poor adhesion (JH)

蒸鍍對合金或是
化合物的沈積成
份控制性差



Dual E-gun
evaporator

(交大半導體技術中心)

Silicon Etching Technique

The slide features a light blue background with a white grid pattern. In the top-left and bottom-right corners, there are 3D ball-and-stick molecular models. The top-left model shows a chain of atoms with black, white, and red spheres. The bottom-right model is more complex, showing a network of atoms with black, white, and red spheres, and is partially overlaid by a series of blue, wavy lines that sweep across the bottom of the slide.

溼式與乾式蝕刻

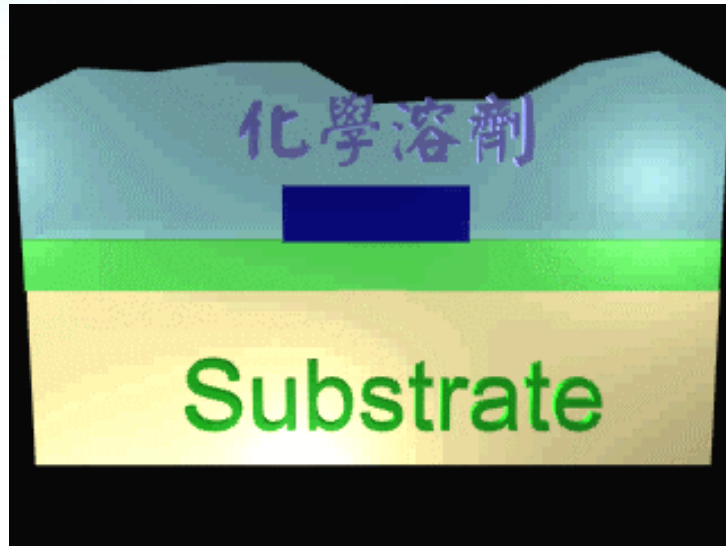

濕式蝕刻法

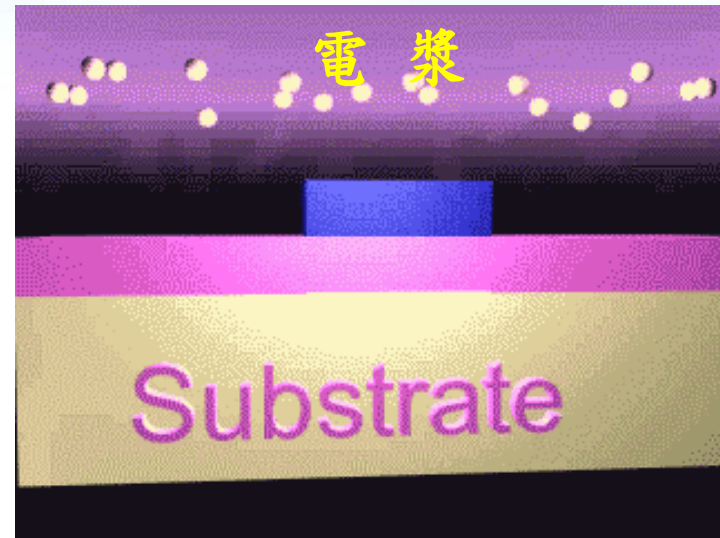

乾式蝕刻法





矽濕式蝕刻技術

Silicon Wet Etching Technique

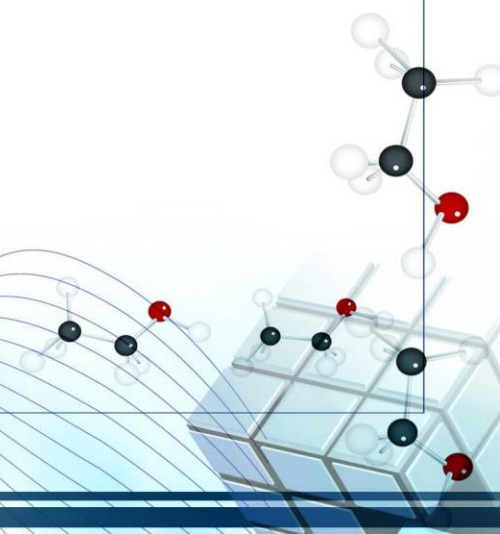

Wet Etch (1) — Isotropic Etching of Silicon

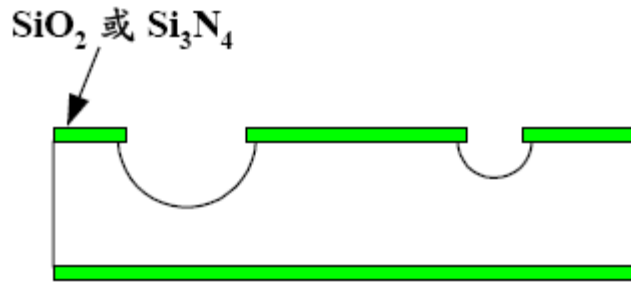

Agitation

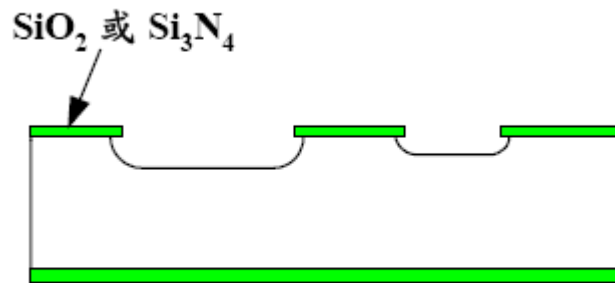

No Agitation

Effects of mask geometry and agitation for isotropic wet etching

- Etchant:
HNA (HF, HNO₃, CH₃COOH)
- Room temperature (<50°C)
- Diffusion control
- High etching rate (50μm/min)
- Undercut mask
- Mask:
Au/Cr or Si₃N₄ is good
SiO₂ is simple
- Undercut嚴重
- Dimension定義嚴重失真

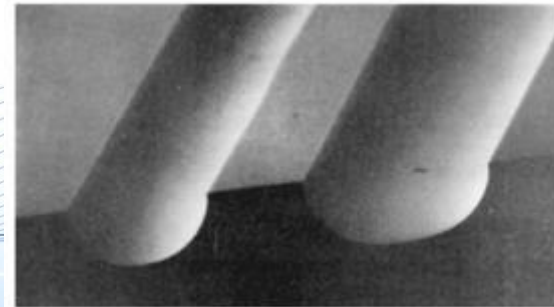

Wet Etch (2) — Anisotropic Etching of Silicon

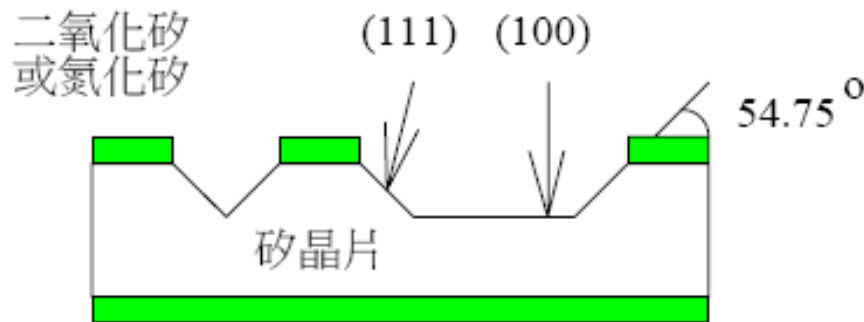

(a) $\langle 100 \rangle$ 矽晶片

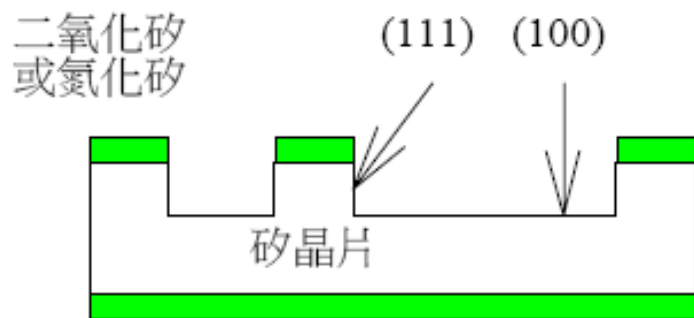

(b) $\langle 110 \rangle$ 矽晶片

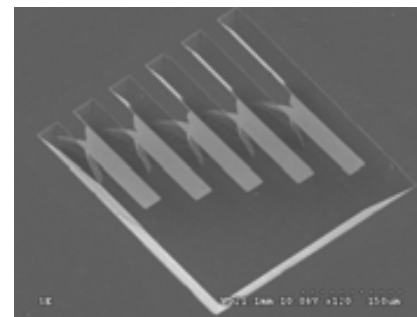
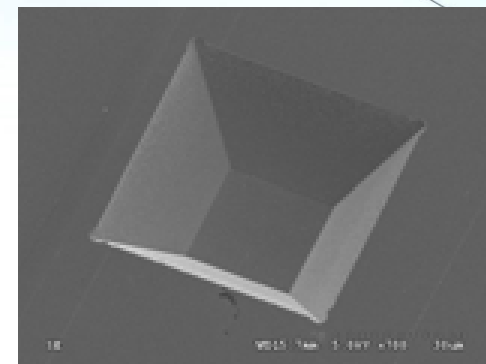
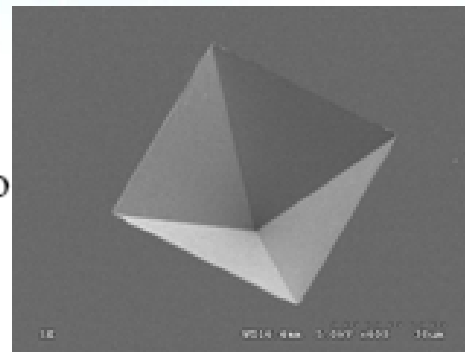

(100)

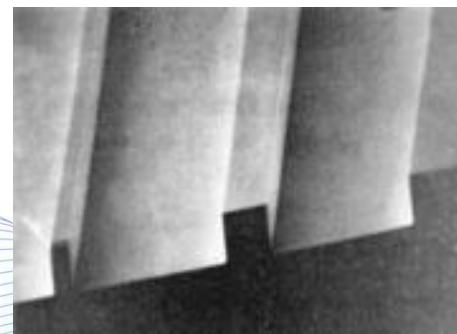

(110)

- Etchant:
KOH, TMAH, EDP, H₂N₄

Wet Etch (3) — 蝕刻液組成與蝕刻特性

蝕刻液	組成	溫度 (°C)	蝕刻率 (μm/min)	(100)/(111) 蝕刻率比值	摻雜硼蝕刻率 降低倍數	蝕刻幕罩與 蝕刻率(nm/min)
KOH (water)	44 g 100 ml	85	1.4	400:1	$\geq 10^{20} \text{ cm}^{-3}$ 降低20倍	二氧化矽(1.4) 氮化矽
KOH (isopropyl)	50 g 100 ml	50	1.0	400:1		
ethylenediamine pyrocatechol (water)	750 ml 120 g 100 ml	115	0.75	35:1	$\geq 7 \times 10^{19} \text{ cm}^{-3}$ 降低50倍	二氧化矽(0.2) 氮化矽, 金, 鉻, 銀, 銅, 鈮
ethylenediamine pyrocatechol (water)	750 ml 120 g 240 ml	115	1.25	35:1		
TMAH (water)	25 %	80	0.4	*	$\geq 2.5 \times 10^{20} \text{ cm}^{-3}$ 降低40倍	二氧化矽
H₂N₂ (water, isopropyl)	100 ml 100 ml	100	2.0	*	無相關性	二氧化矽, 鋁
NaOH (water)	10 g 100 ml	65	0.25-1.0	*	$\geq 3 \times 10^{20} \text{ cm}^{-3}$ 降低10倍	二氧化矽(0.7) 氮化矽

Wet Etch (4) — Etching apparatus

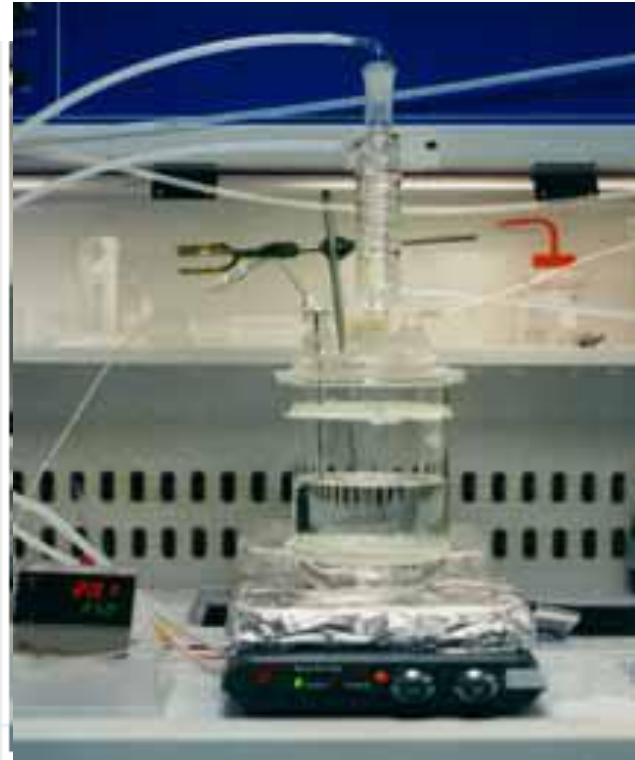
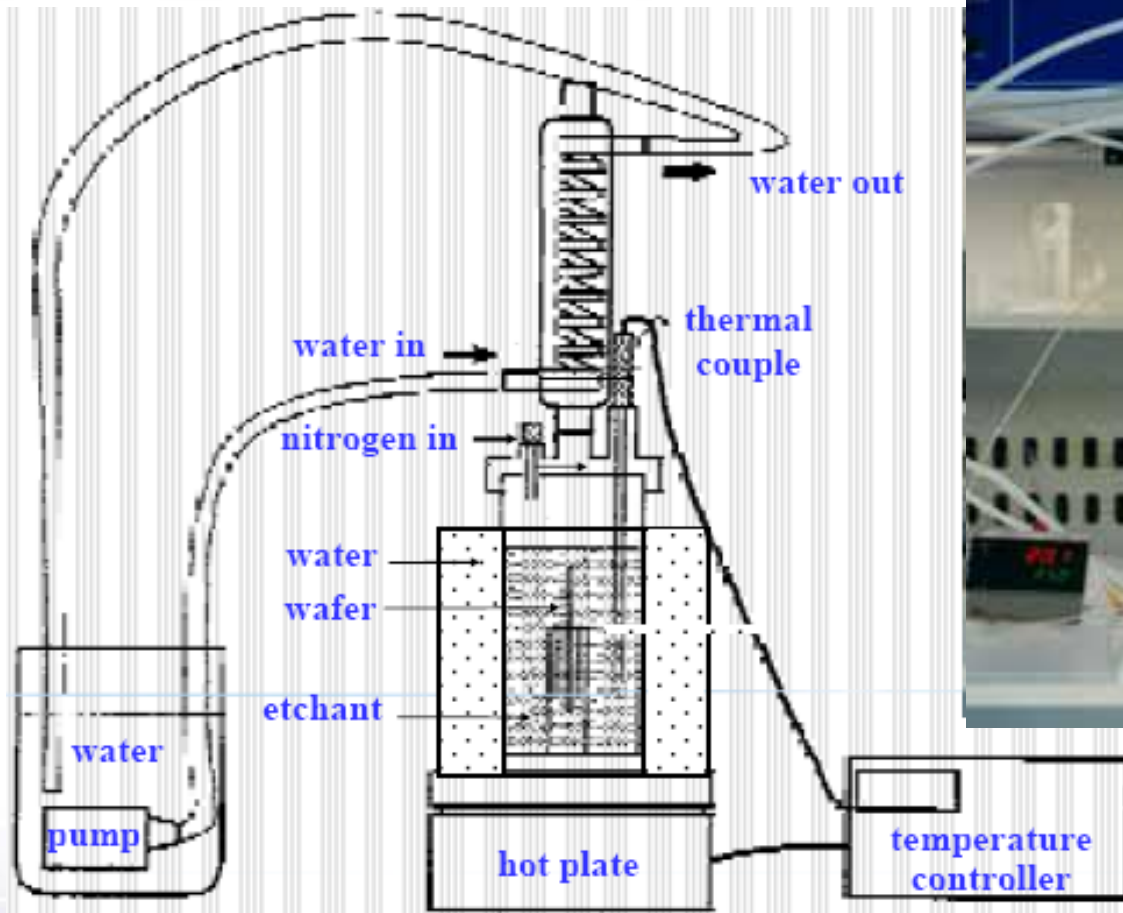

Wet Etch (5) — Corner Compensation

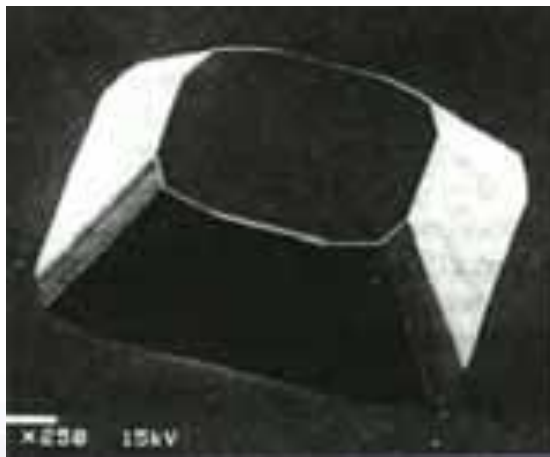
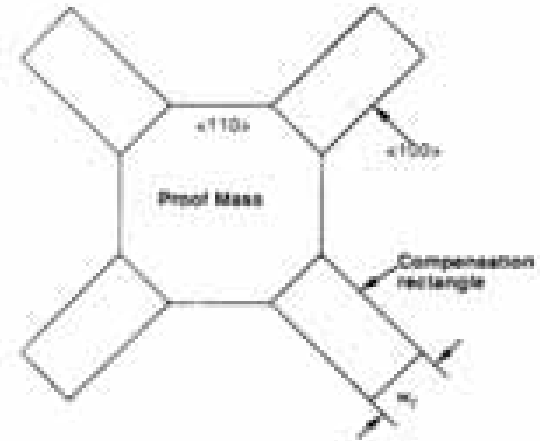
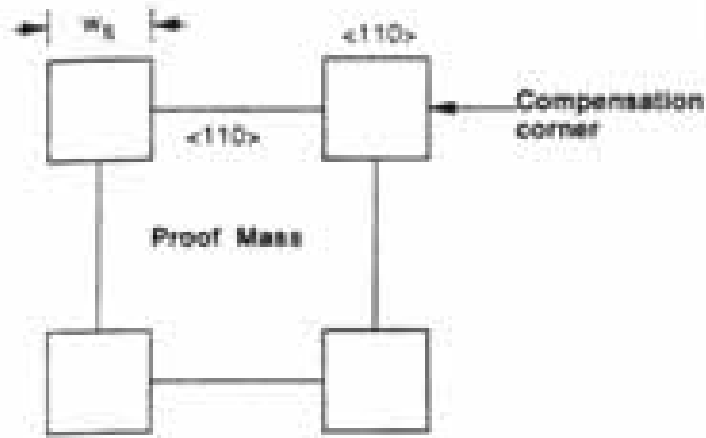

EDP etchant

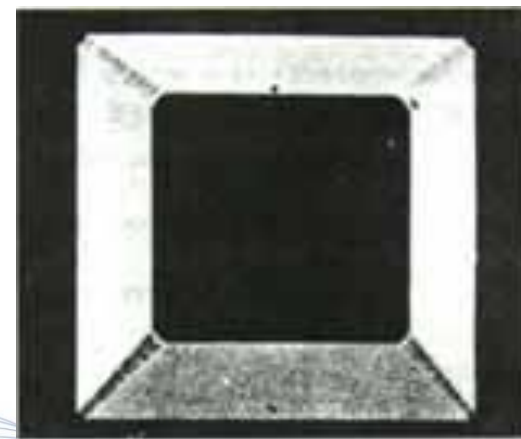

KOH etchant

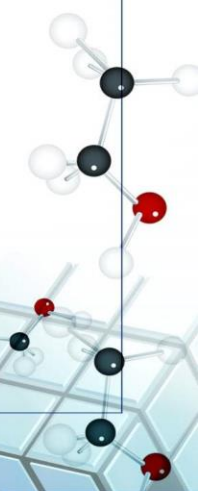
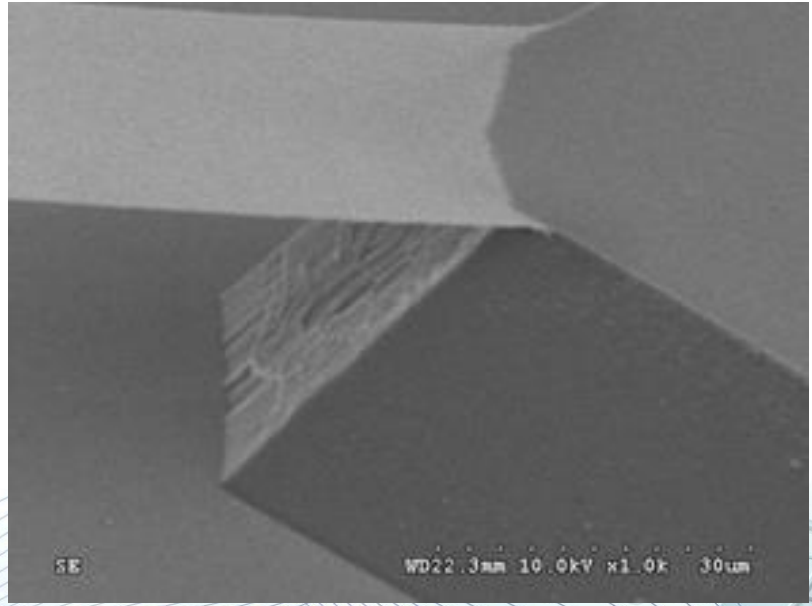
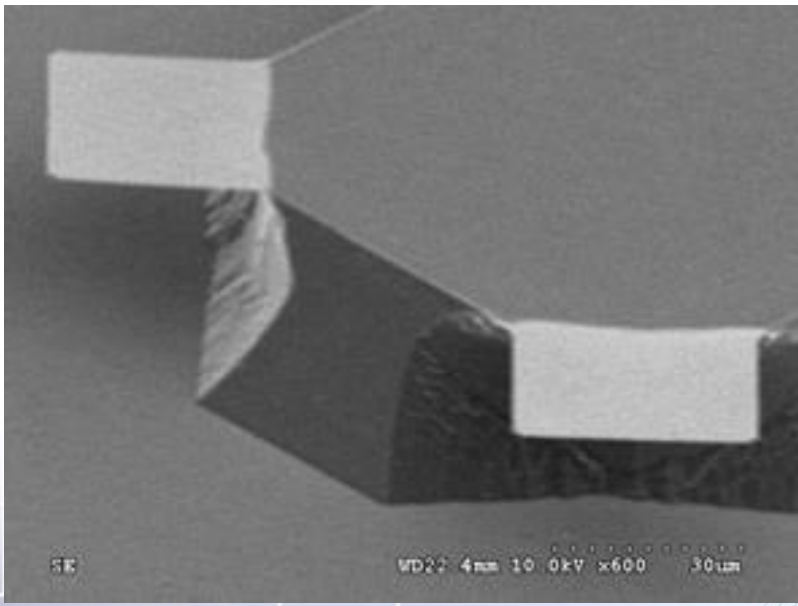
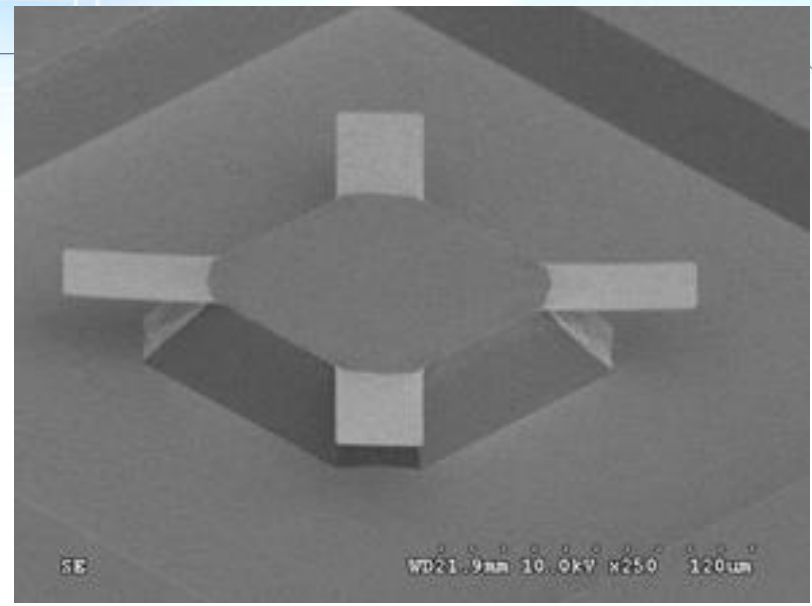
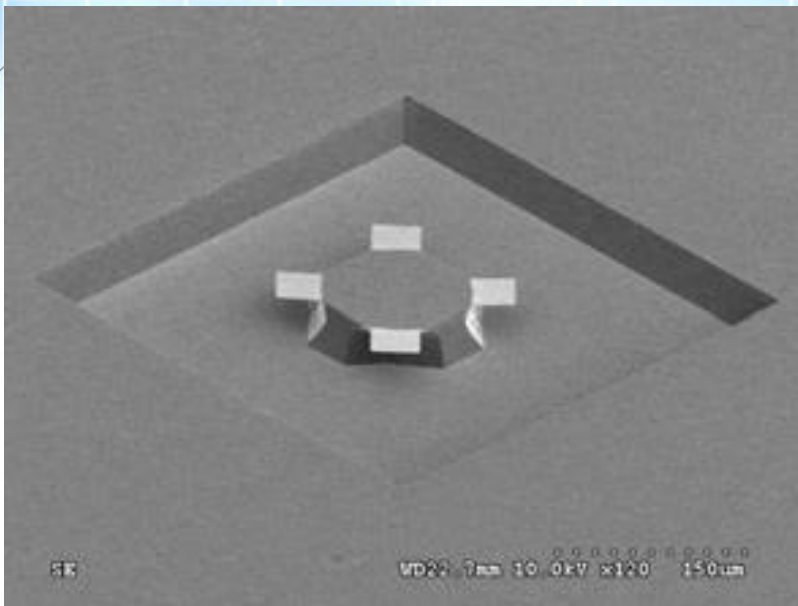

Pure TMAH

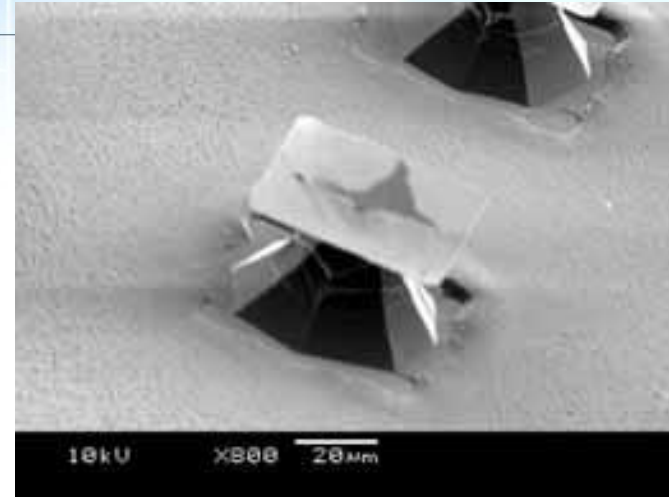
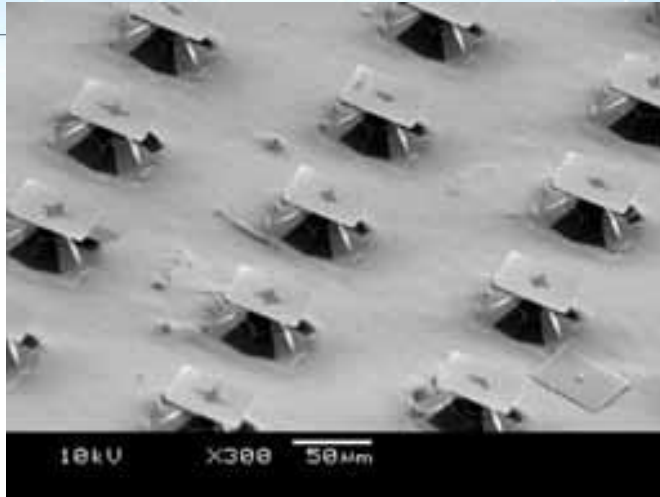

**BR-Added
(添加劑)**

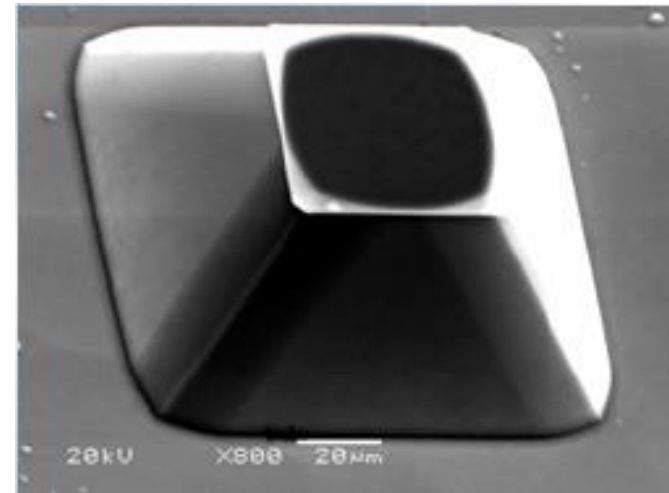

Mesa microstructures etched in TMAH-BR solution and pure solution without using the corner compensation technique.

Wet Etch (6) — Etching stop technology

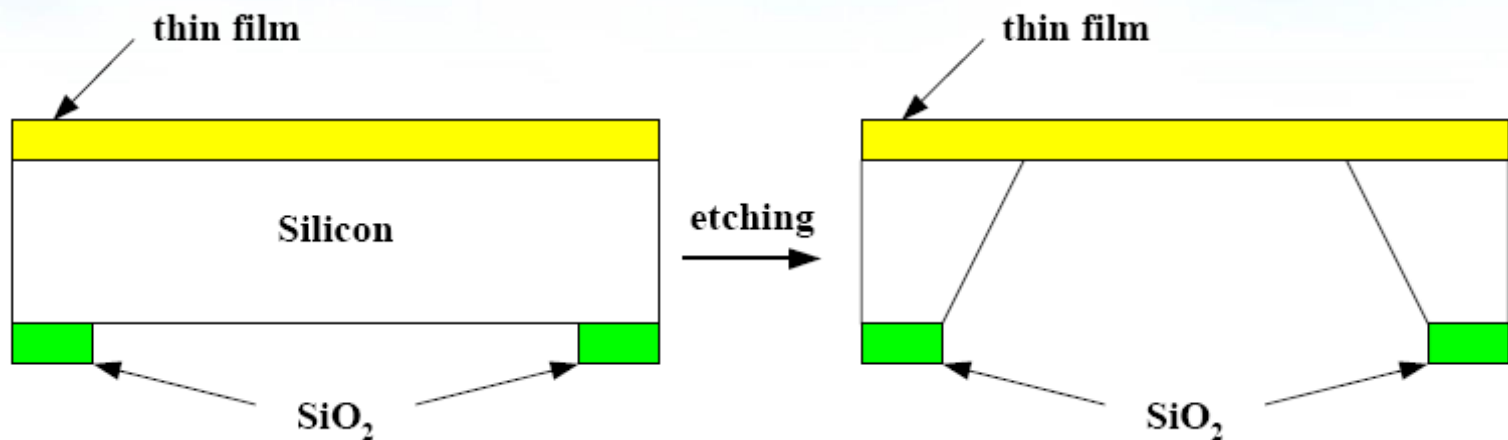

必須使用雙面拋光晶片

薄膜蝕刻終止

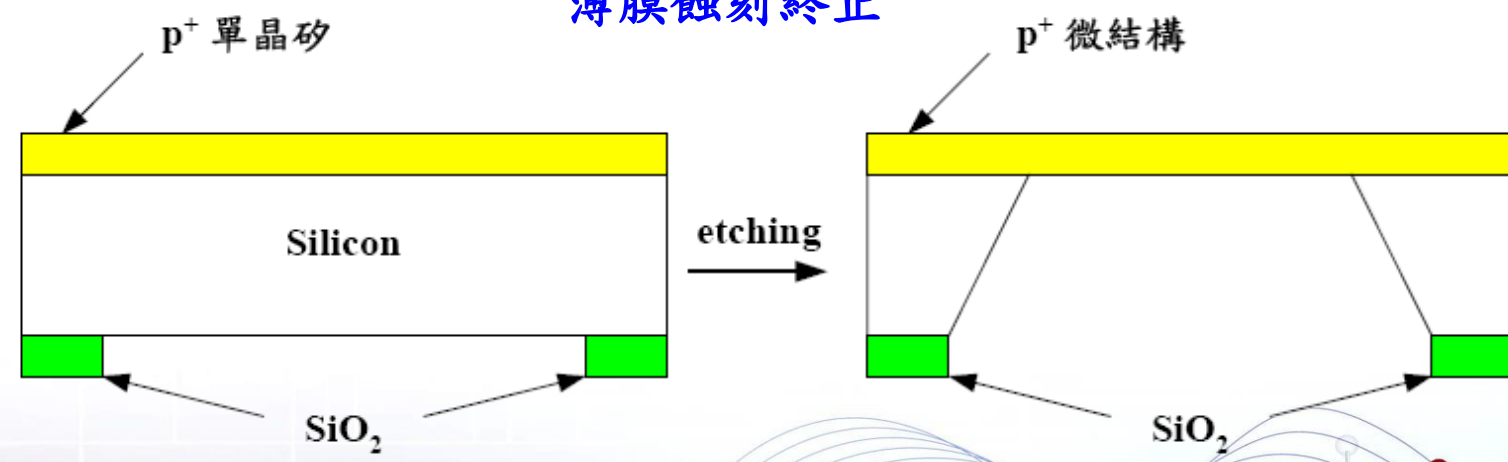

摻雜蝕刻濃度終止

蝕刻率與摻雜物質的型態及摻雜濃度有關



(a) 金字塔結構



(b) 皺狀結構

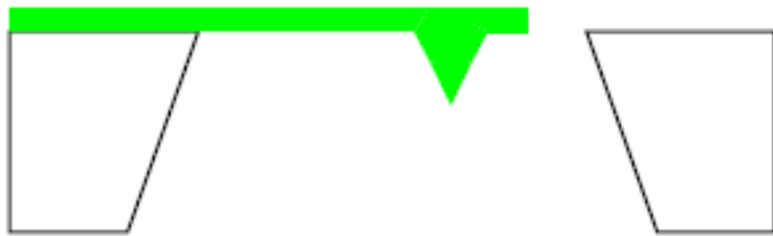

(c) 微探針結構



(d) 碗狀結構

利用非等向溼式蝕刻技術所蝕刻之各種薄膜微結構

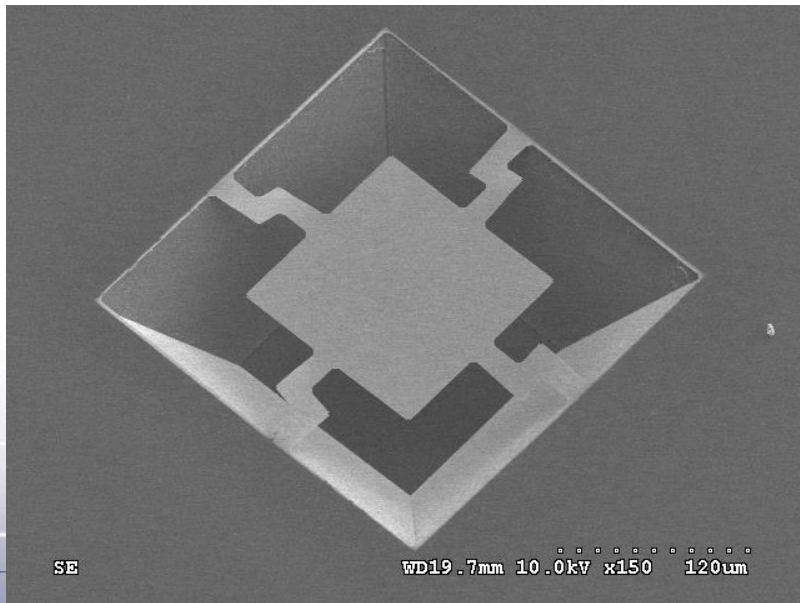
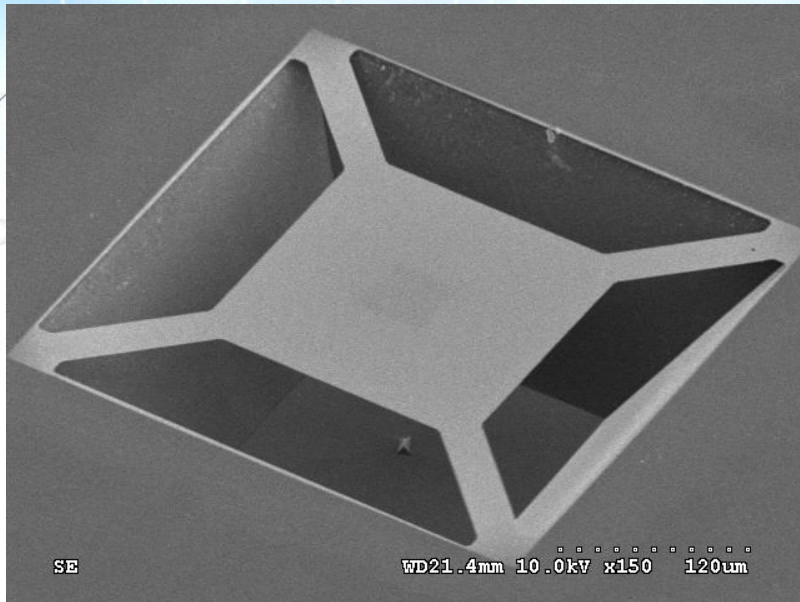

(a) LPCVD沉積 Si_3N_4

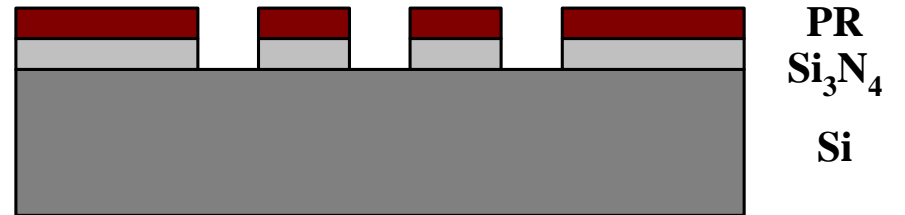

(b) 微影及用RIE蝕刻 Si_3N_4

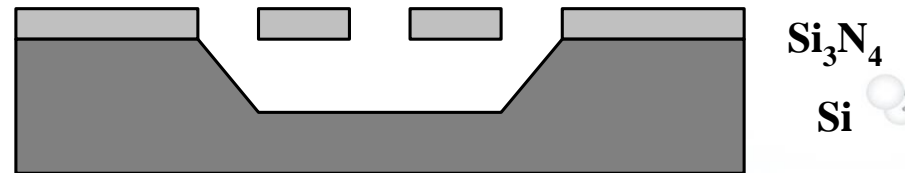

(c) 在KOH蝕刻液中蝕刻

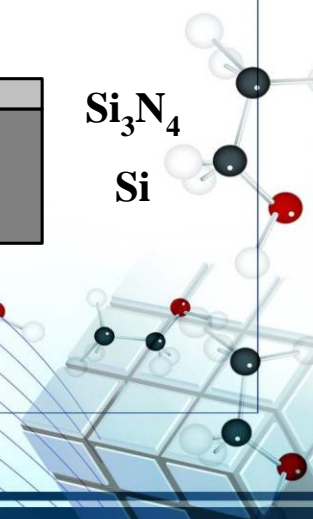

Wet Etch (7) — 3-D 結構的限制

受限於單晶矽的鑽石立方結晶，蝕刻出來的角度是特定而無法改變的，不能蝕刻出特殊形狀的微結構，所以設計元件時就得考慮結構上的基本限制。

SiO₂ 或 Si₃N₄



Agitation

SiO₂ 或 Si₃N₄



No Agitation

二氧化矽
或氮化矽

(111) (100)

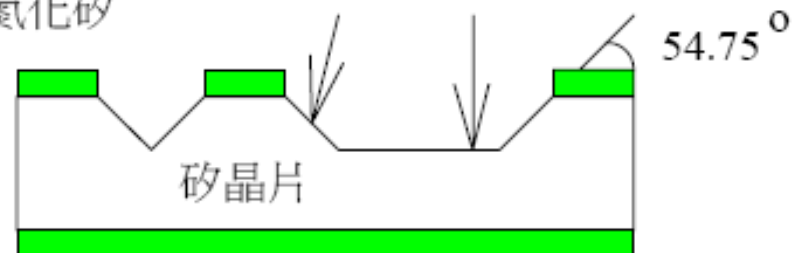

(a) <100>矽晶片

二氧化矽
或氮化矽

(111) (100)

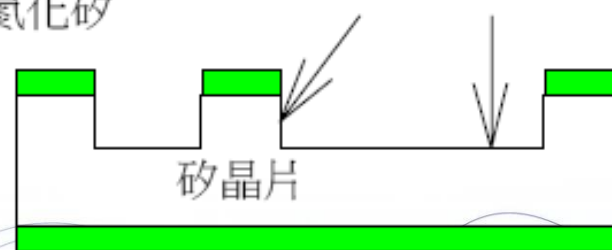

(b) <110>矽晶片

Wet Etch (8) — 蝕刻保護的必要性

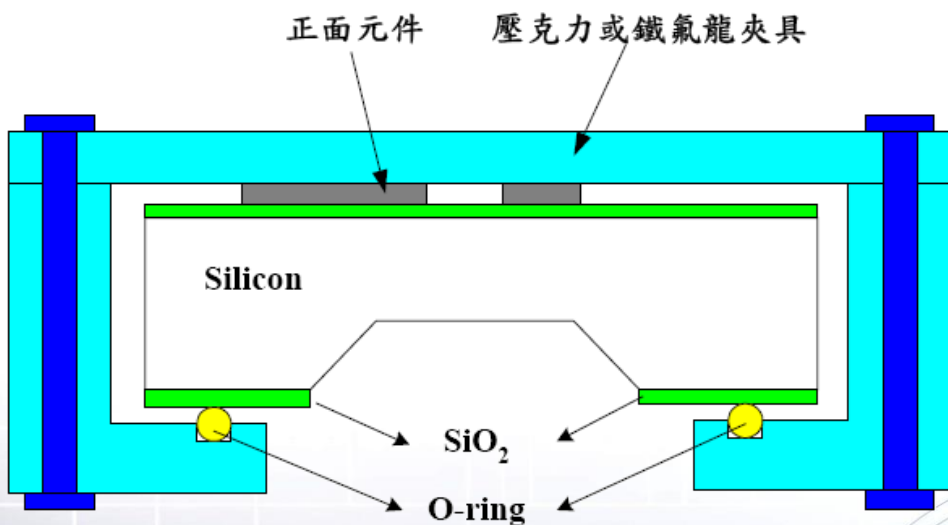
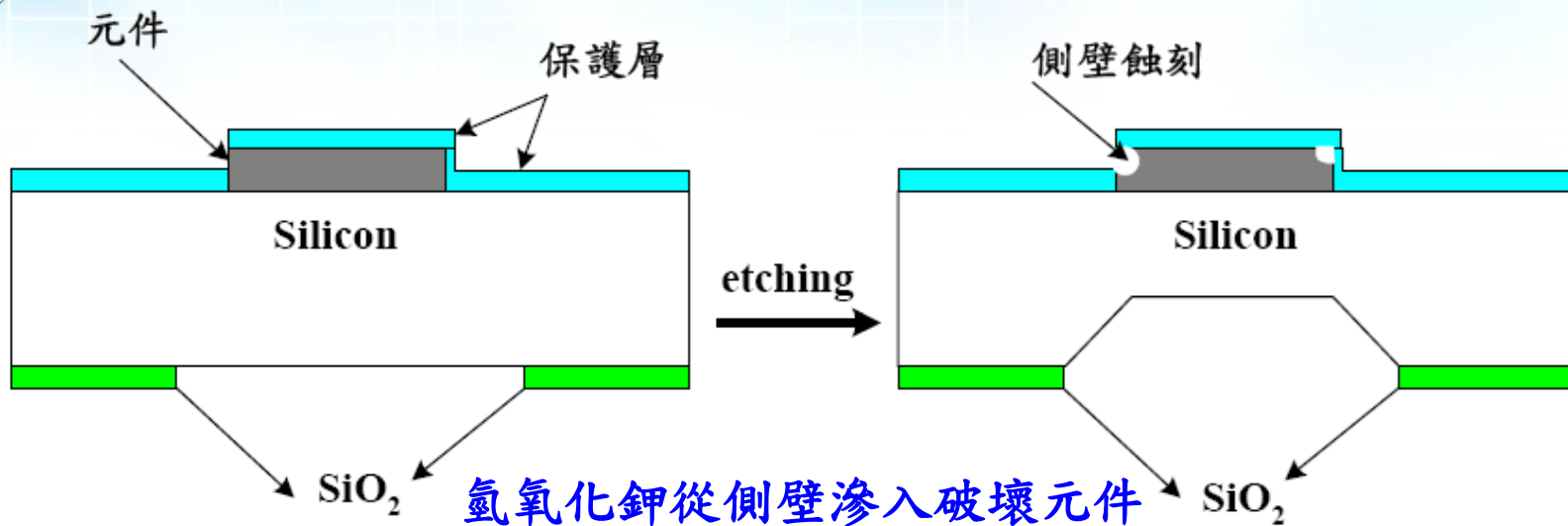

利用鐵氟龍或壓克力夾具保護正面的元件



鐵氟龍夾具



矽乾式蝕刻技術

Silicon Dry Etching Technique

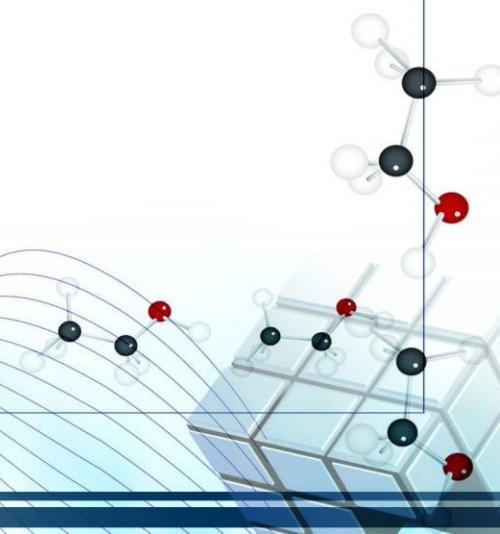

Dry Etch (1)

乾蝕刻沒有液態的蝕刻溶液，主要分為物理濺擊或離子銑削、電漿蝕刻、與介於兩者之間的活性離子蝕刻三類，右圖是三者蝕刻特性與壓力、激發能量的分類關係圖。

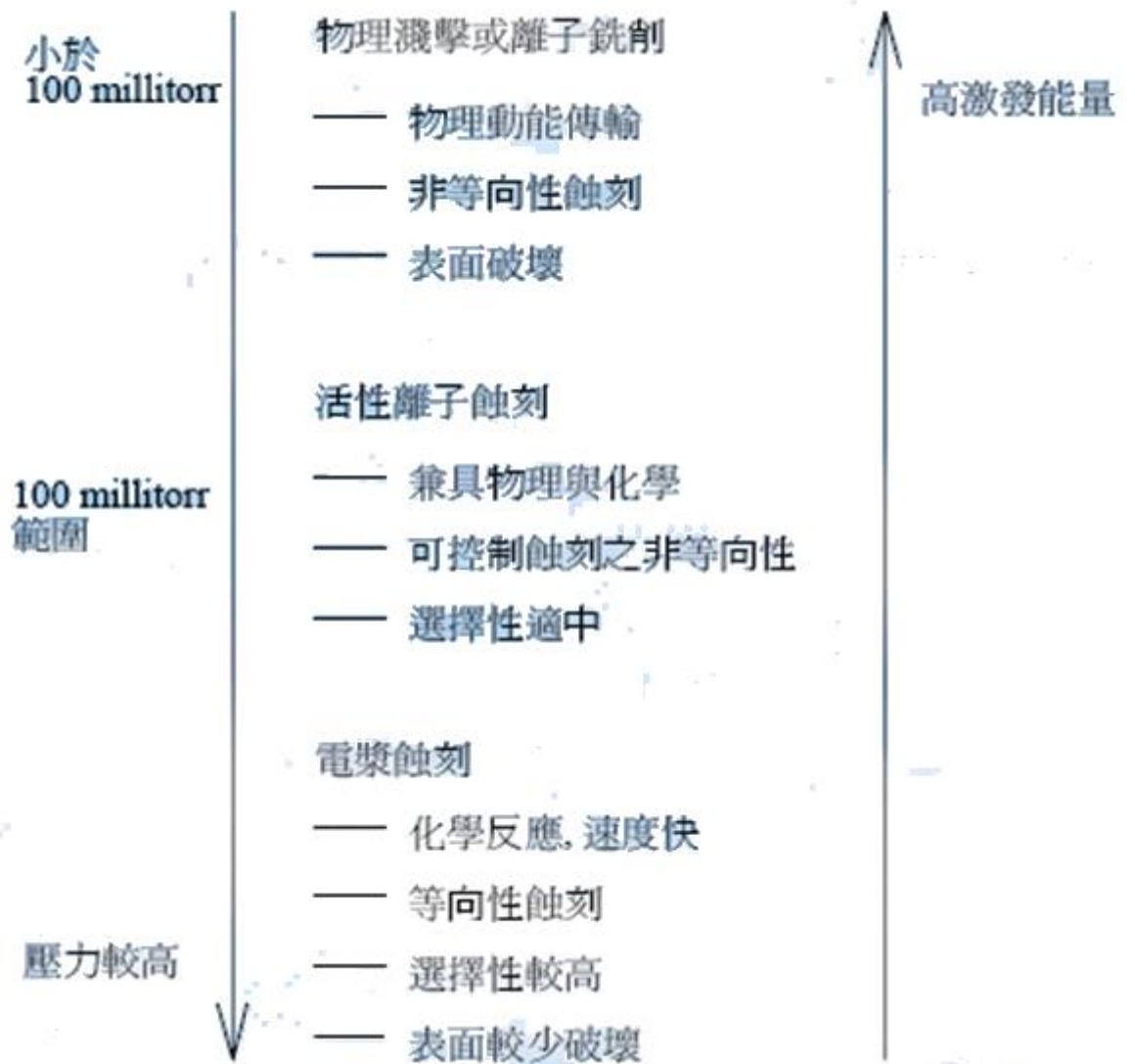

物理濺擊或離子銑削、電漿蝕刻、與活性離子蝕刻之關係

Dry Etch (2) — RIE and ICP



反應性離子蝕刻(RIE)系統,
NTNU MOEMS Lab.



感應耦合電漿蝕刻(ICP-RIE)系統,
PIDC

Dry Etch (3) — 活性離子蝕刻系統示意圖

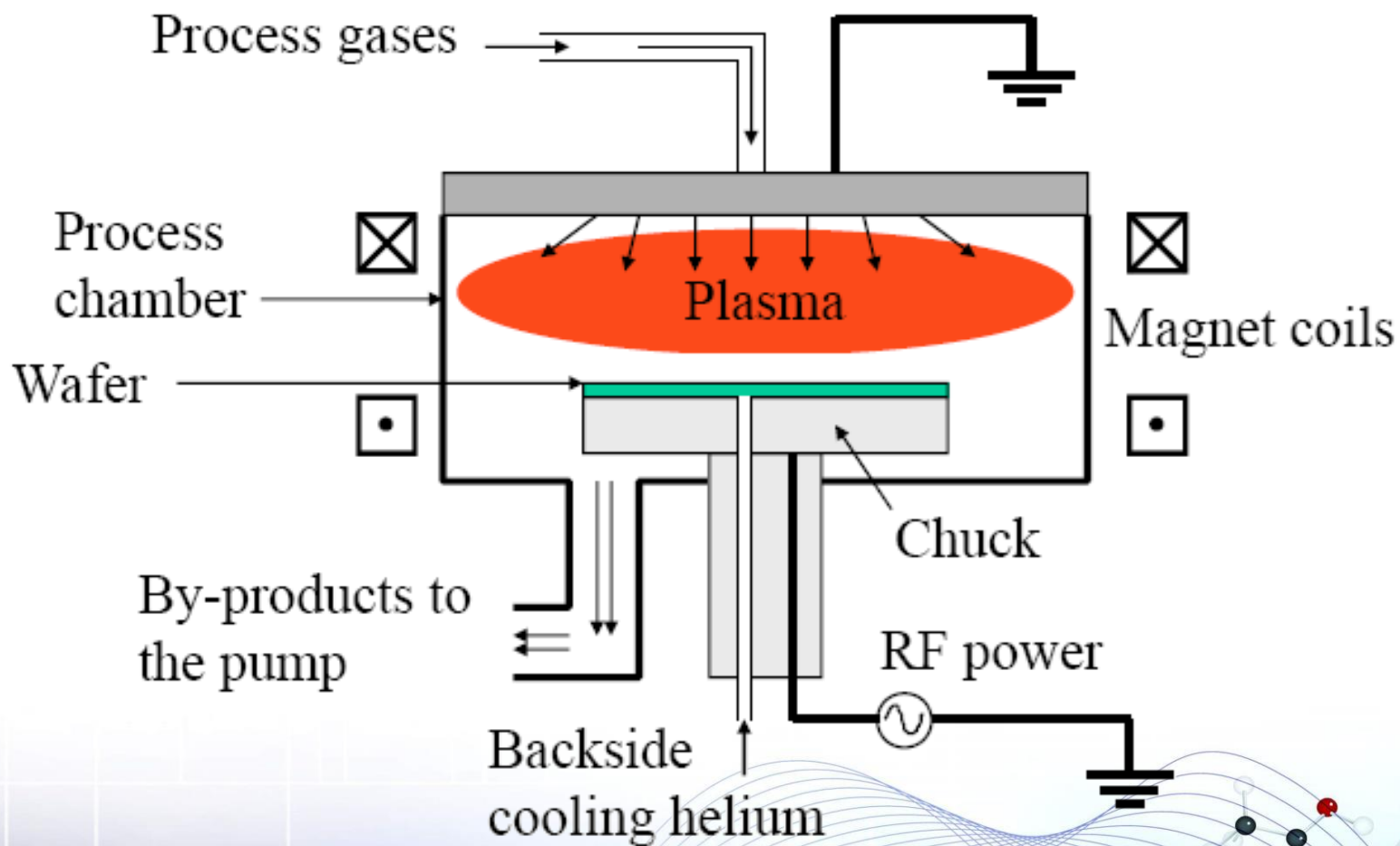

Dry Etch (4) — 電漿蝕刻

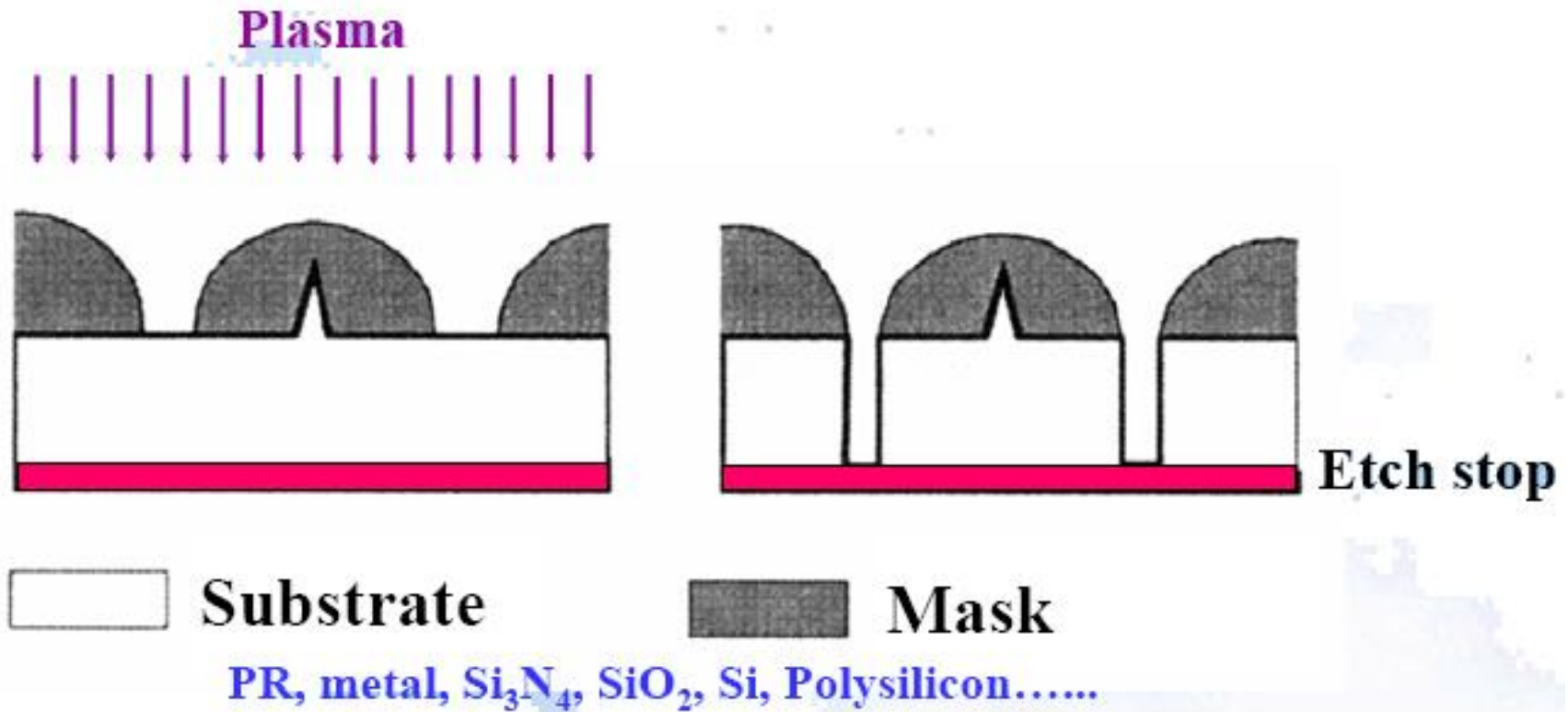

Mask材料選擇的原則：高選擇比, 蝕刻深度, 非等向性...

Dry Etch (5) — 蝕刻原理

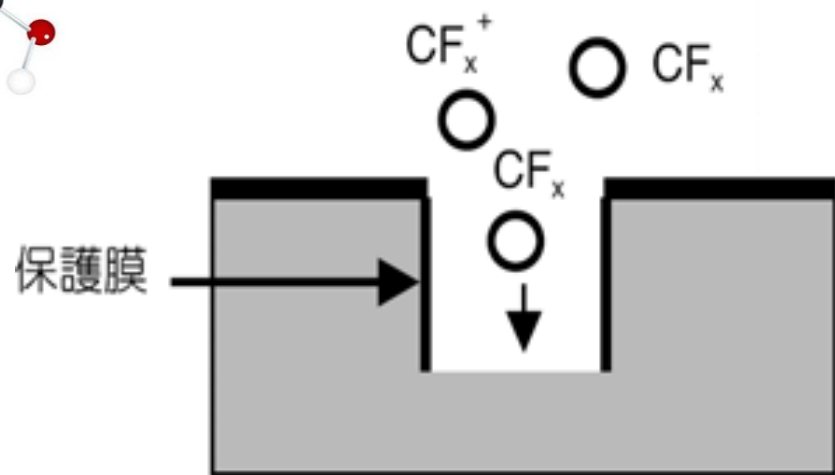

保護製程步驟

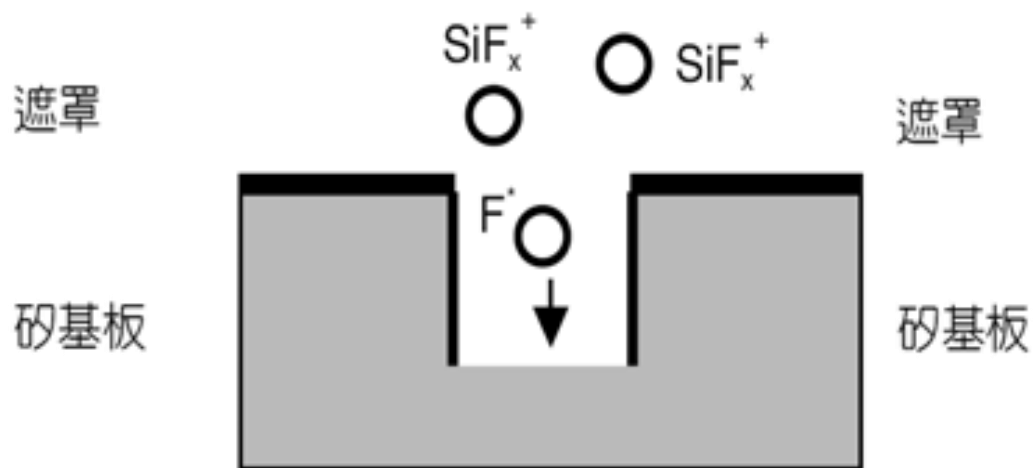

蝕刻製程步驟

Dry Etch (6) — ICP-RIE SEM圖

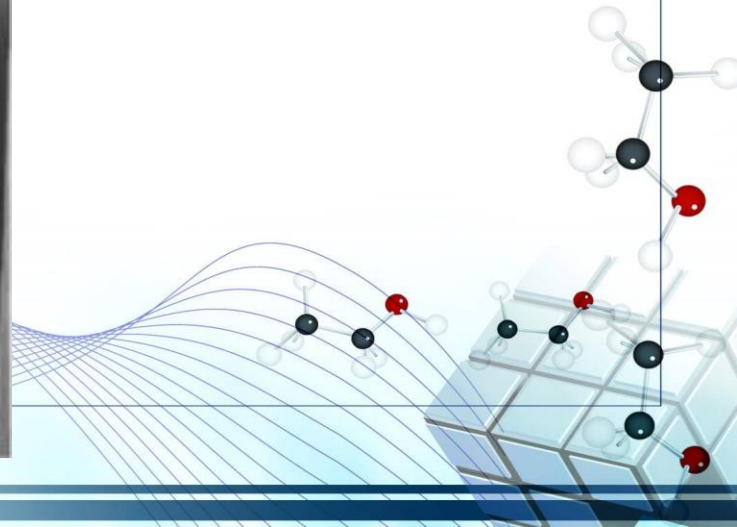
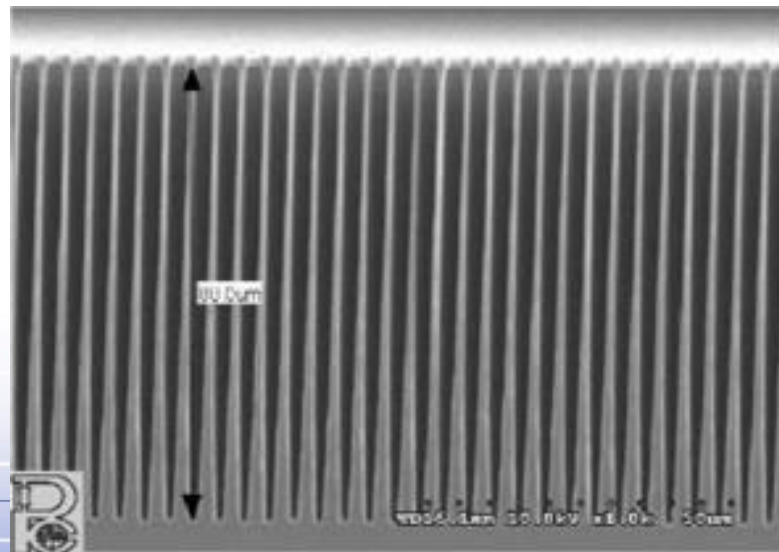
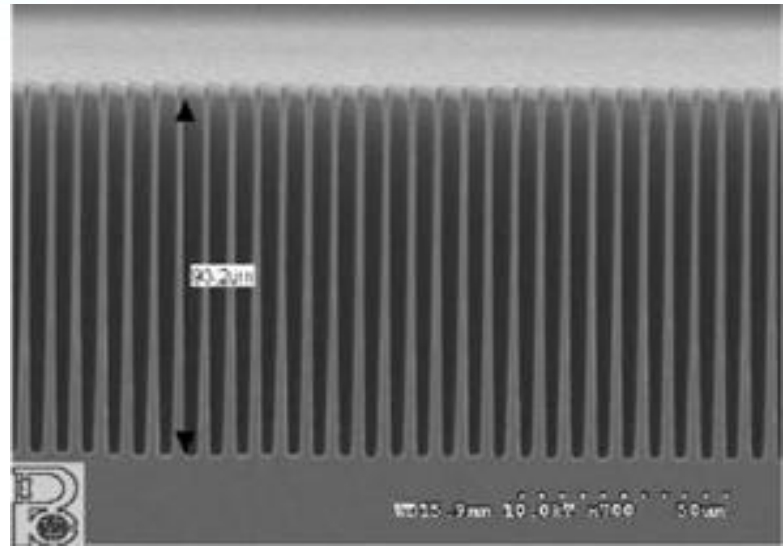
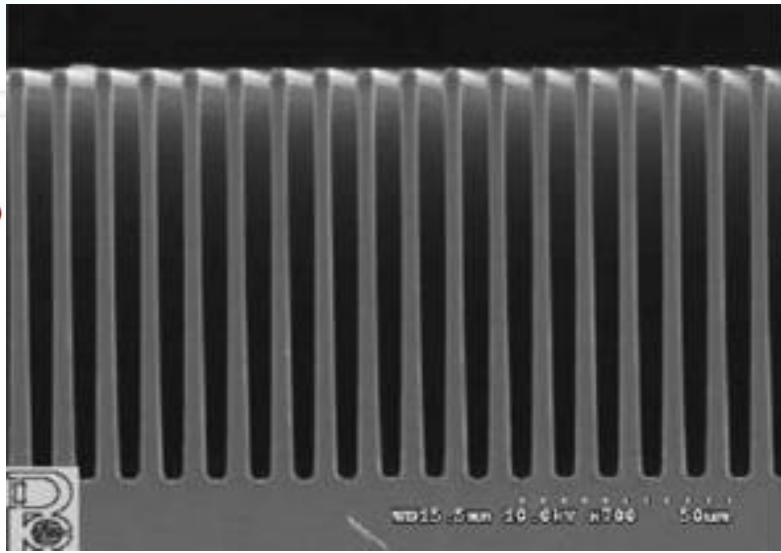

Dry Etch (6) — ICP-RIE 缺陷

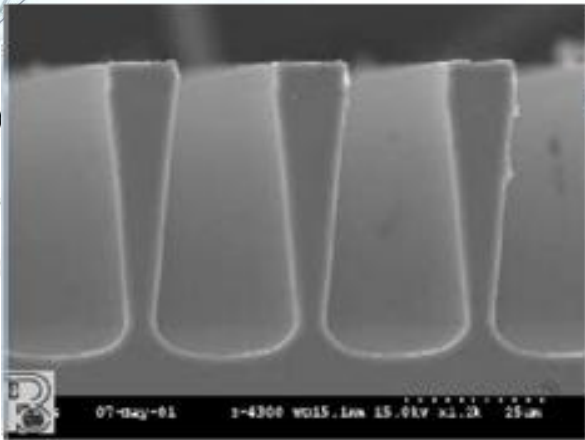

蝕刻溝槽外擴

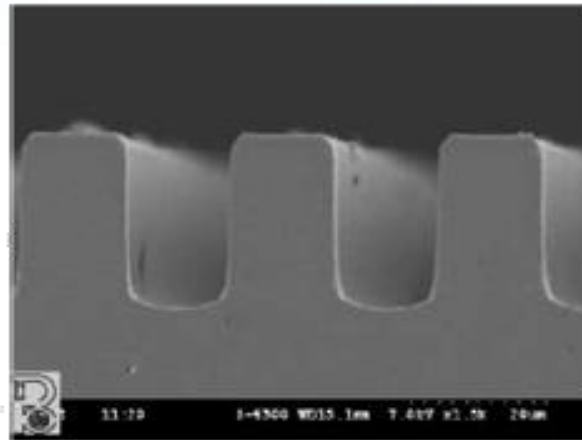

蝕刻溝槽內凹

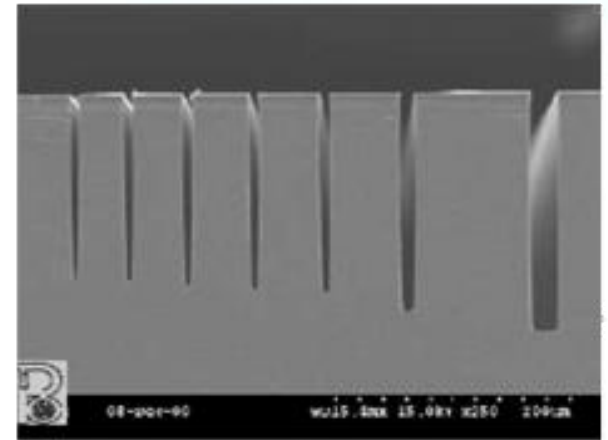

蝕刻延遲

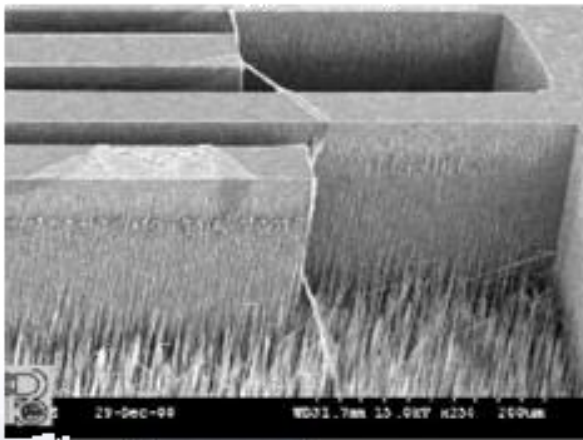

雜草現象

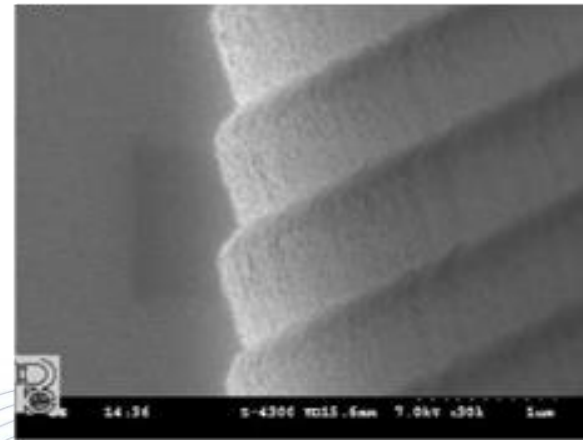

側壁橫紋

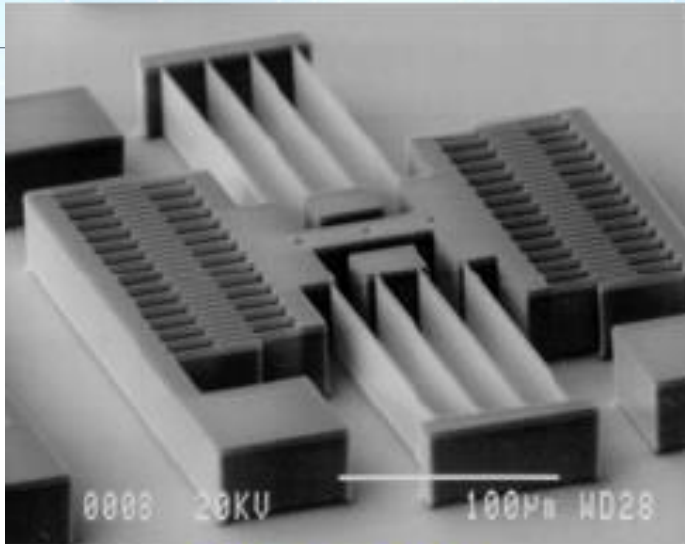

Comb-driver

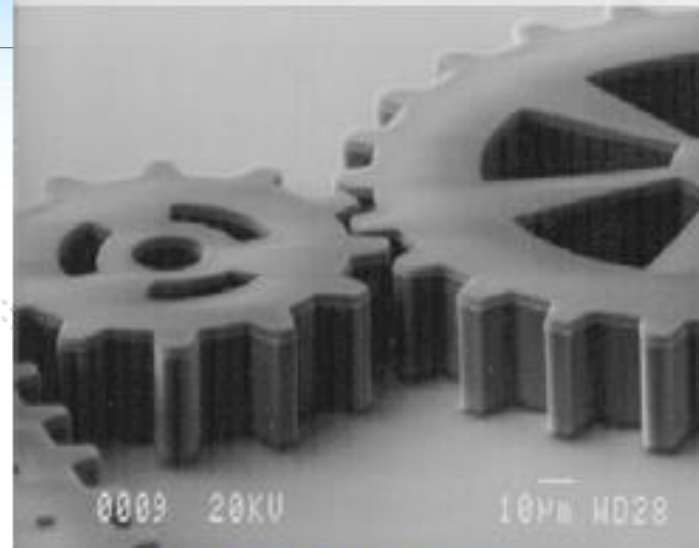

Nested Gears

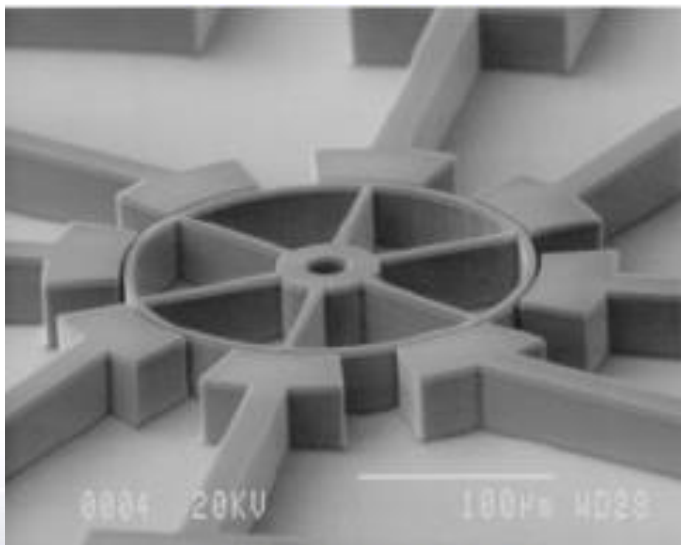

Micromotor

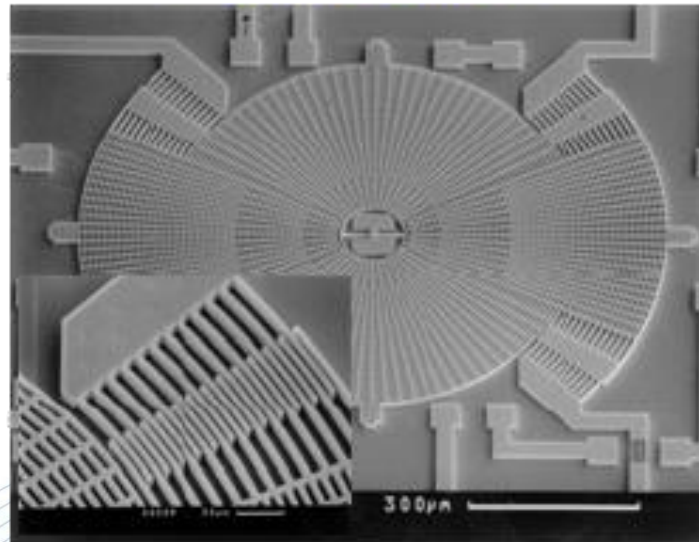

Gyroscope

MCNC, USA

氮化矽乾、溼式蝕刻的差異性

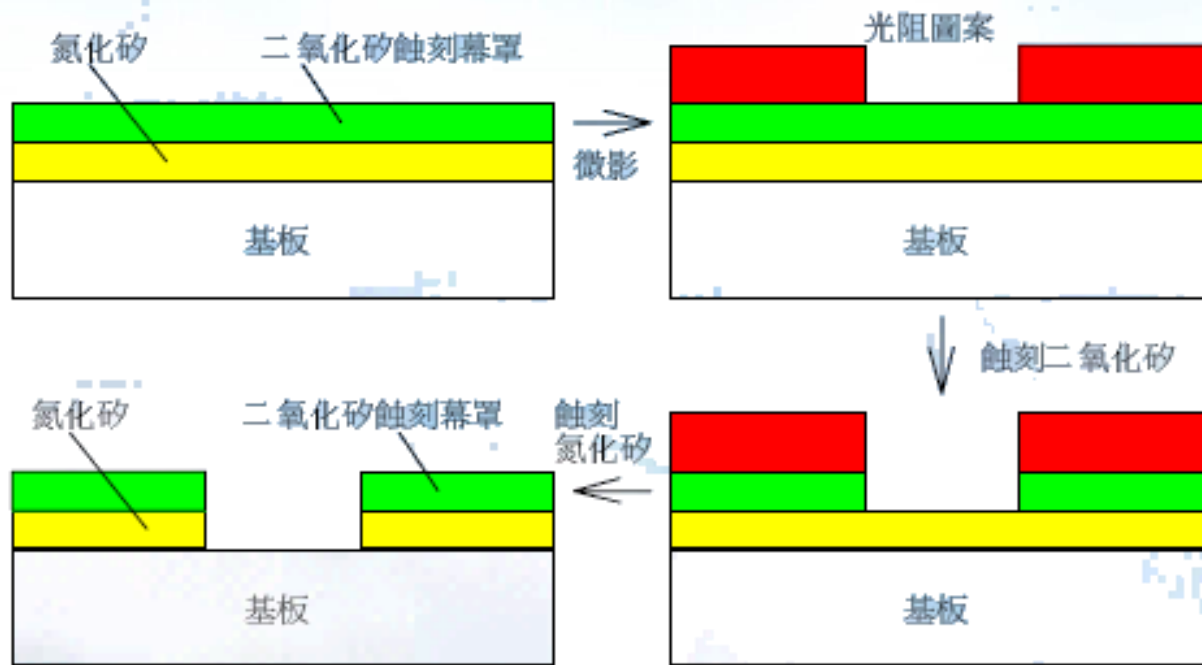

溼式蝕刻： $\text{H}_3\text{PO}_4(85\%)@175^\circ\text{C}$

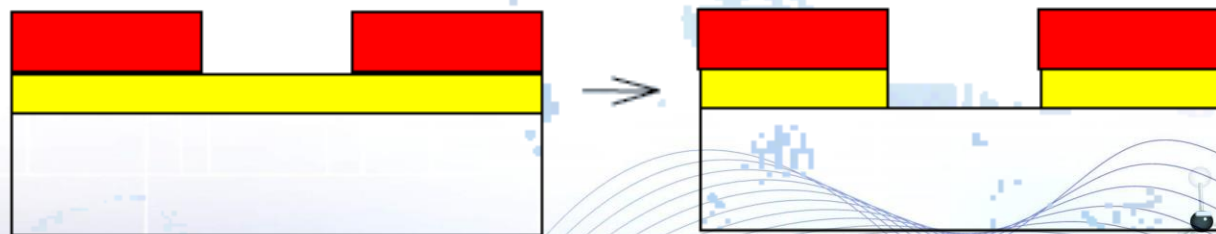

乾式蝕刻： $\text{CF}_4(10 \text{ sccm})@60 \text{ mTorr}$

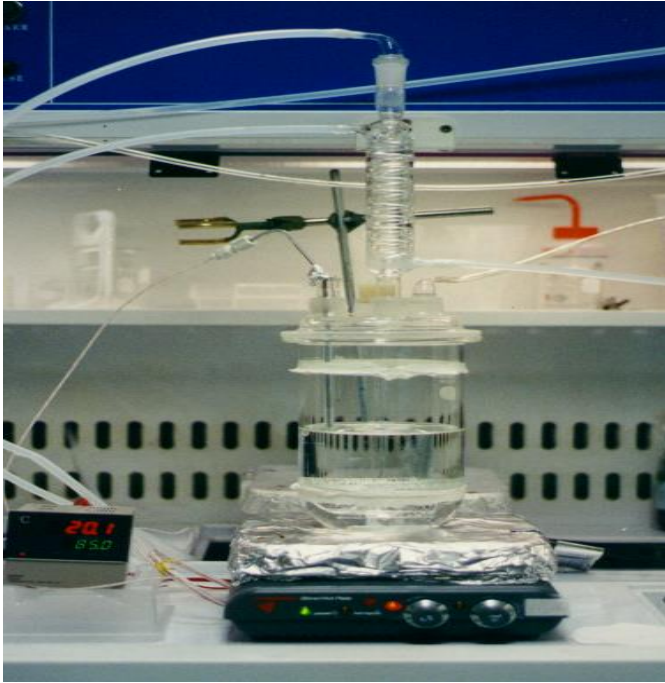

濕式蝕刻裝置(成本低)



感應耦合電漿蝕刻(ICP-RIE)系統,
ITRC (成本極高)

LIGA, UV-LIGA, SIGA



LIGA與LIGA-Like製程與應用技術

MEMS領域中微製造技術分類表

非 矽 基 微 加 工	LIGA技術	X-ray深光刻術	精密電鑄技術 • 純金屬電鑄 • 合金電鑄	微微成形技術 • 塑膠微結構成形 熱壓成形、射出成形 輪壓成形、紫外線硬化法 • 陶瓷微結構成形 粉末射出成形、帶板鑄造	
	LIGA-like 技術	紫外光厚膜光阻微影 準分子雷射微加工 感應耦合電漿離子蝕刻* 電子束光刻術			
	微機械加工	切削加工	微切削加工、微鑽孔加工、微銑削加工、微輪磨加工		
		非切削加工	微電鍍成形、微壓模成形、微射出成形、微沖壓成形		
		特殊加工	微放電加工、雷射微加工、離子束微加工、電子束微加工、超音波微加工、原子力顯微加工術		
高分子微加工技術	微雷射光合高分子成形(Microstereolithography, μ -SL) 軟式微影技術(Soft Lithography) 微接觸印刷術(Microcontact Printing, μ -CP) Micromolding in Capillaries (MIMIC) Microtransfer Molding (μ -TM) Replica Molding (REM)				
其他低溫製程技術與材料	聚對二甲苯(Parylene)、明膠(Gelatin)蛋白質、鐵氟龍(Teflon)、矽膠(Silicone)				

註：感應耦合電漿離子蝕刻技術通常歸類為非等向性高深寬比矽基蝕刻技術。

LIGA製程：Lithographie:光刻 Galvanoformung:電鑄 Abformung:模造

1. 光刻

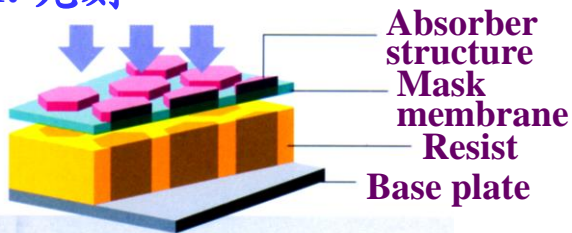

2. 顯影

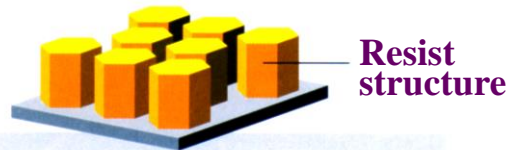

3. 電鑄

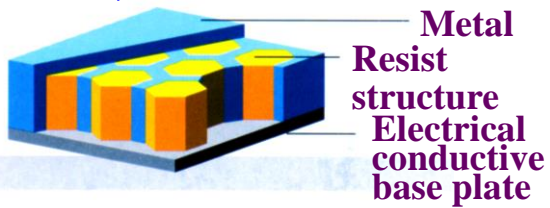

4. 金屬模仁



5. 模造

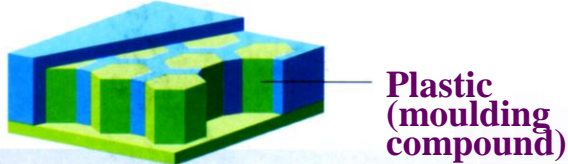

6. 脫模

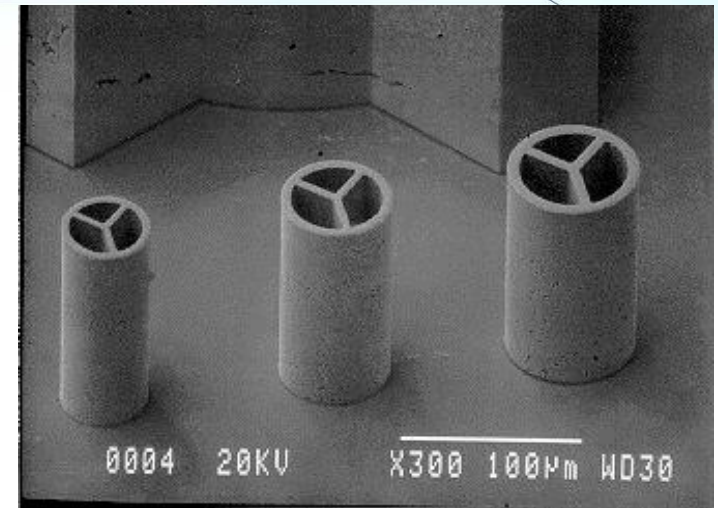
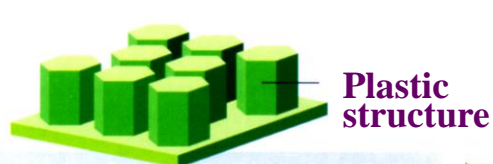

MCNC

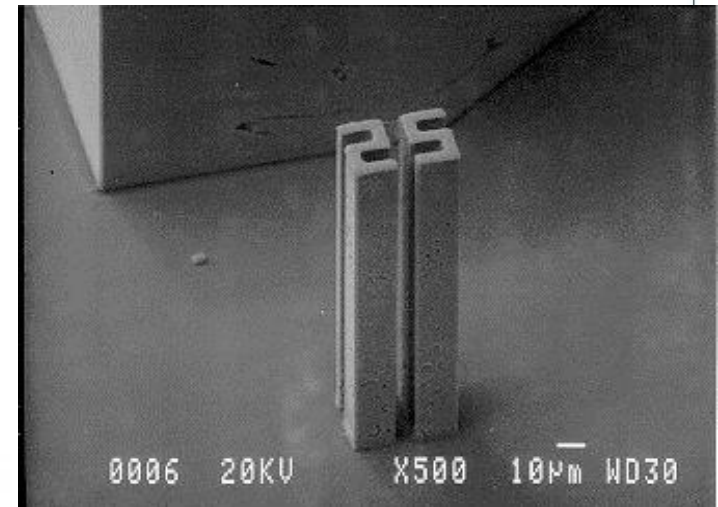

高深寬比(high aspect ratio)
的微結構

Source: Institut für Mikrotechnik Mainz (IMM), Germany

LIGA製程技術的技術關聯圖

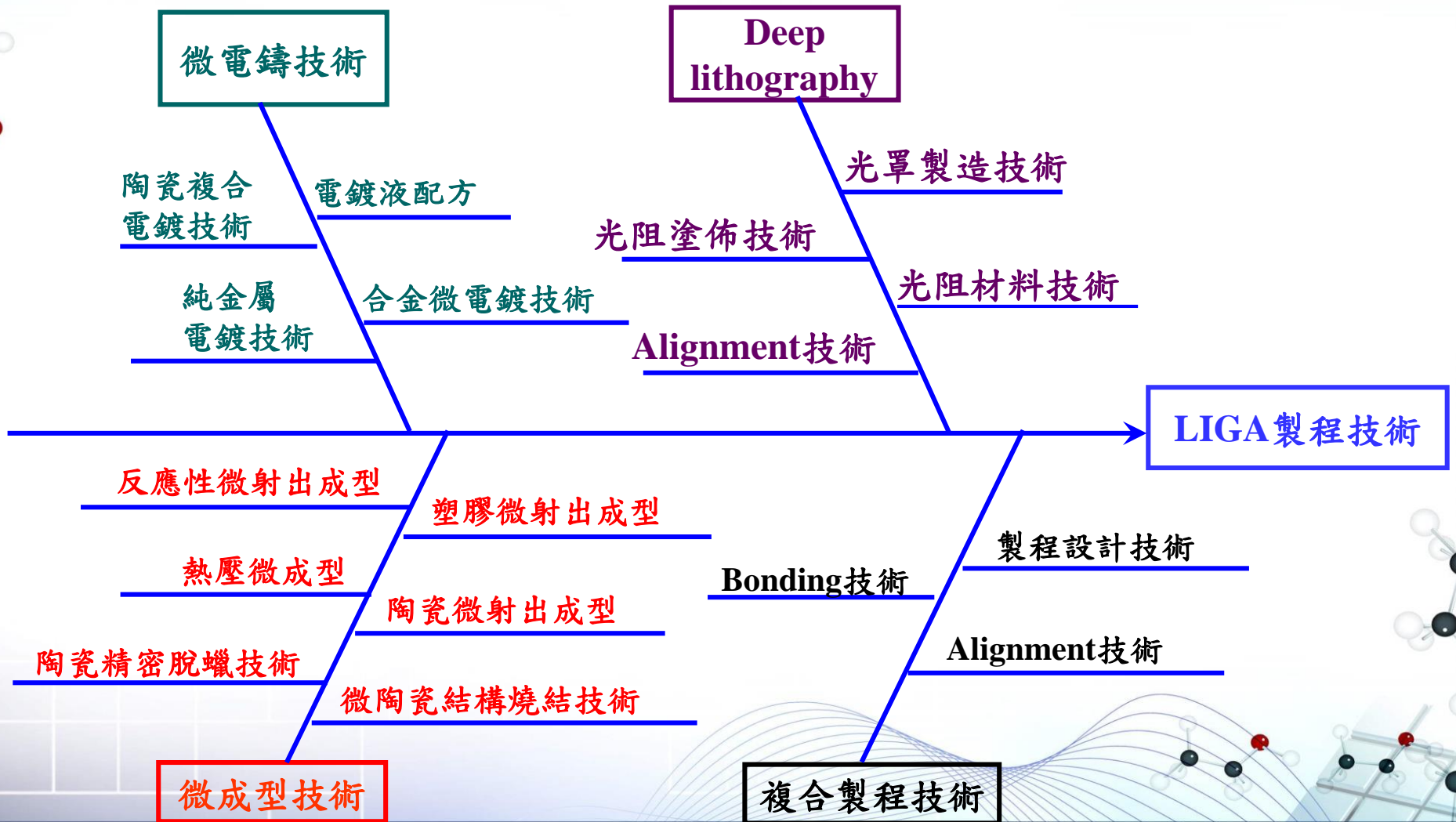

犧牲層LIGA (S-LIGA)技術的應用範圍

- 微感測器的懸浮結構
- 可控制流量進出的微閥門
- 各型微致動器的移動或轉動結構等.....

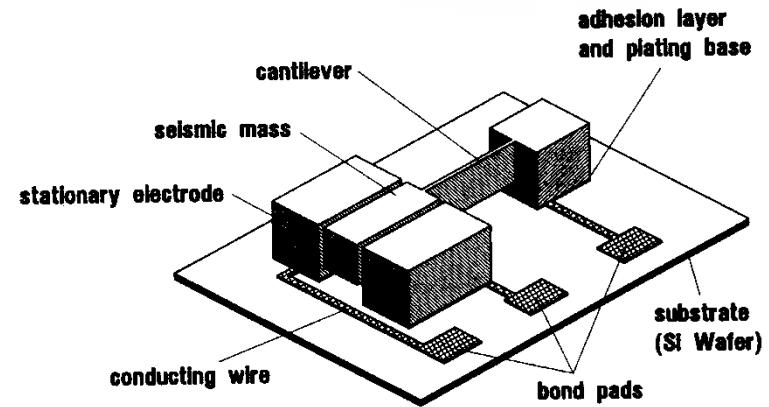

Acceleration microsensor

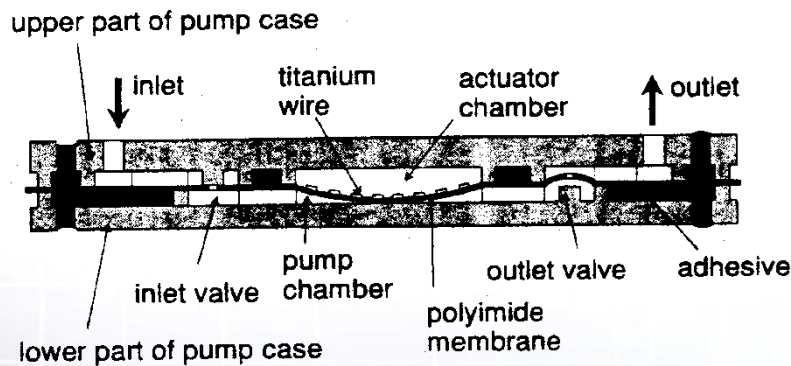

Micropump

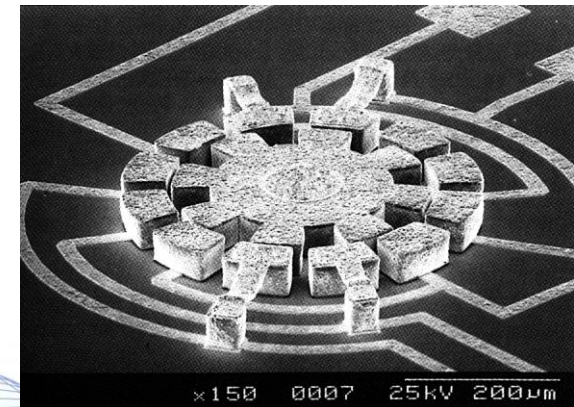

Micromotor

Key Features of X-ray LIGA Microstructures

- Realization of arbitrary shape
- Extreme structure height (>mm)
- Extreme aspect ratio (>100)
- Minimum lateral dimensions $0.5 \pm 0.1 \mu\text{m}$
- Surface roughness $0.03\text{-}0.05 \mu\text{m}$
- Vertical & smooth sidewalls
- Wide variety of materials
- Successful in mass fabrication

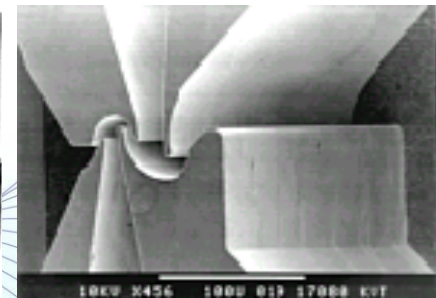
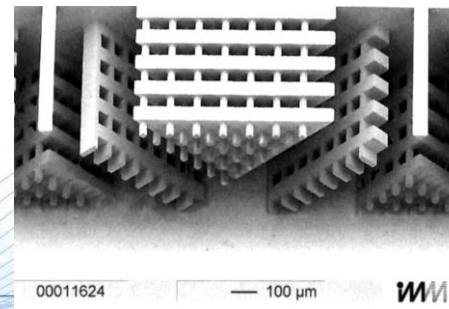
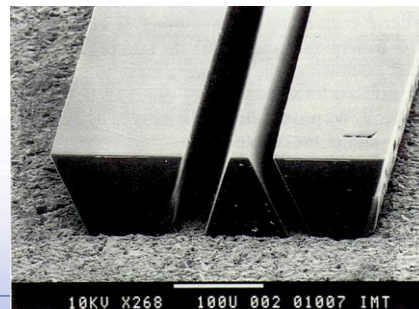
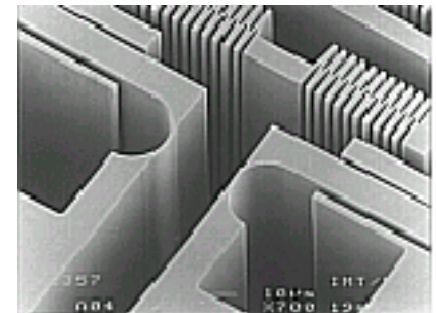
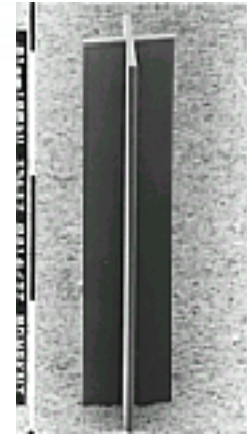

LIGA 製程 vs. 類LIGA 製程

光刻源的差異

LIGA 製程：同步輻射X光

- 加工深度數mm、次微米級精度、深寬比 >100
- 同步輻射光源為一龐大且昂貴的設備
- X-ray 光罩製作複雜且成本高

類LIGA 製程：低成本替代性光源

- 加工深度 $\leq 1\text{mm}$ 、微米級精度、深寬比 ≤ 50
- 紫外光-厚膜光阻微影製程
- 準分子雷射
- 反應性離子蝕刻

Synchrotron Radiation Research Center (for LIGA process)



USA APS



FRANCE ESRF



JAPAN SPring-8

Low-cost Exposure System (for LIGA-like process)



Excimer Laser System

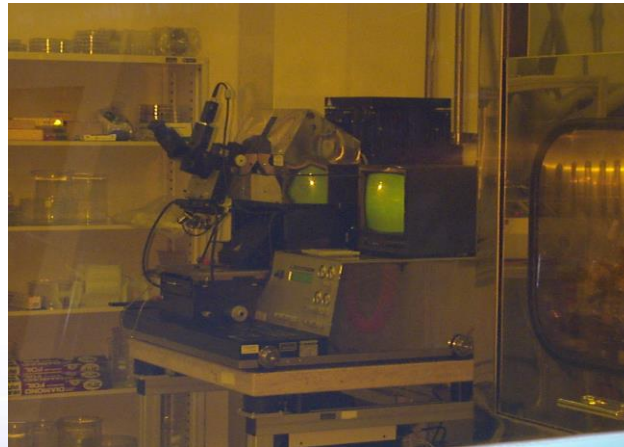

UV mask aligner



ICP-RIE System

Instrument Technology Research Center, ITRC

Photomask of UV Lithography

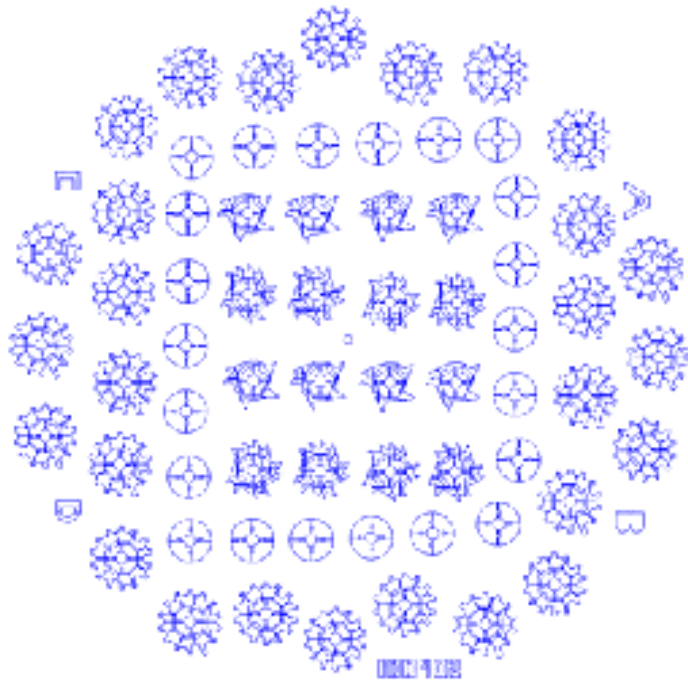

(a) CAD Layout

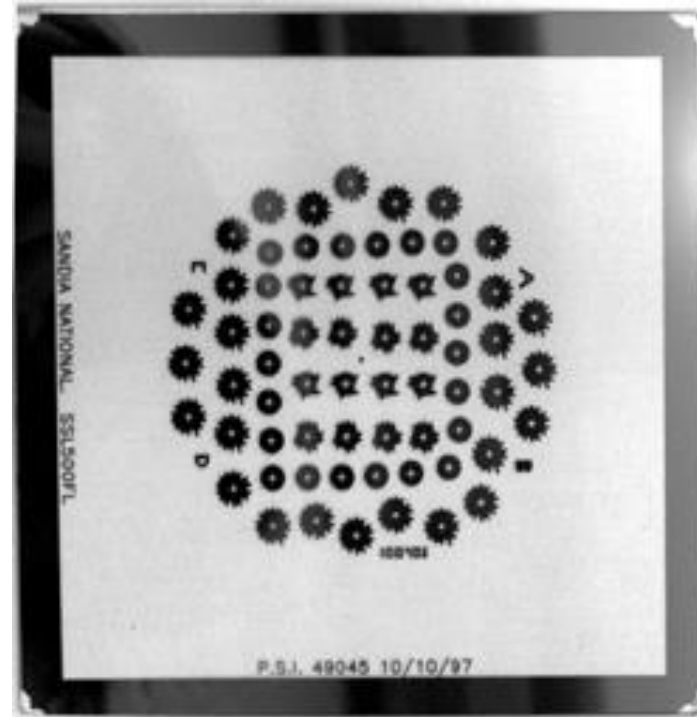

(b) Chrome Mask

Source: <http://daytona.ca.sandia.gov/LIGA/mask.html>
(Sandia National Laboratory, USA)

SIGA 製程

In German:
Silizium-mikrostrukturyr
Galvanoforum
Abformung

In English:
Silicon-microstructuring
Electroforming
Molding

1. 熱氧化沉積 SiO_2 與光阻塗佈

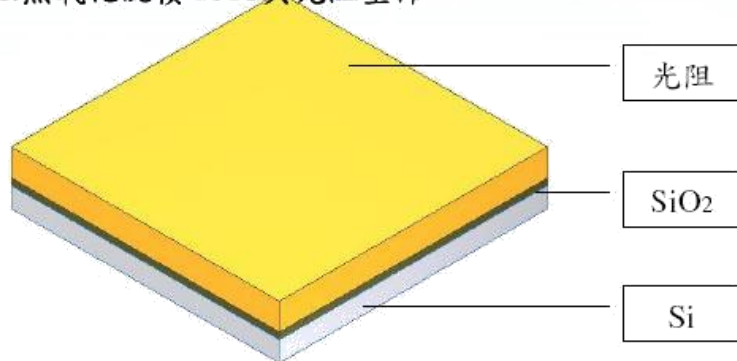

2. 微影及用 BOE 蝕刻 SiO_2

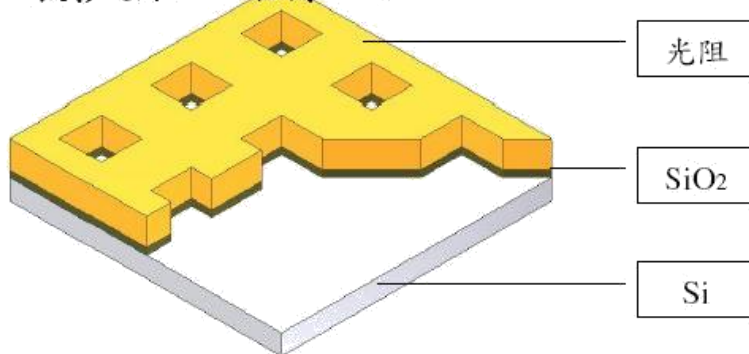

3. 蝕刻



4. 使用 BOE 去除 SiO_2

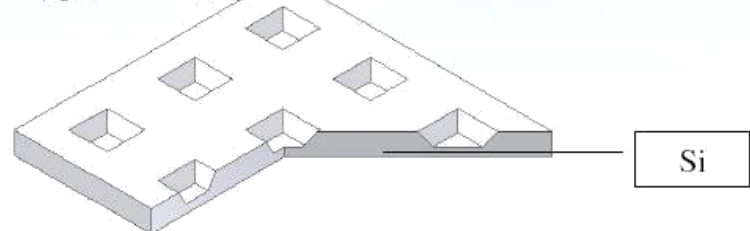

5. 蒸鍍電鍍起始層 Cr/Cu

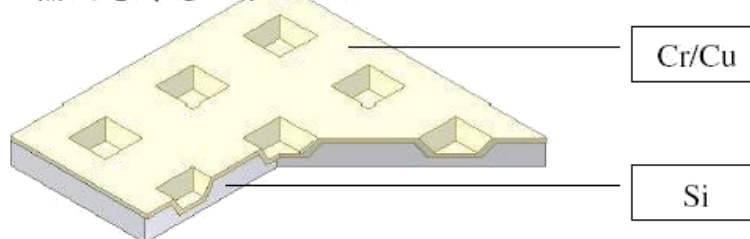

6. 微鍍電鍍

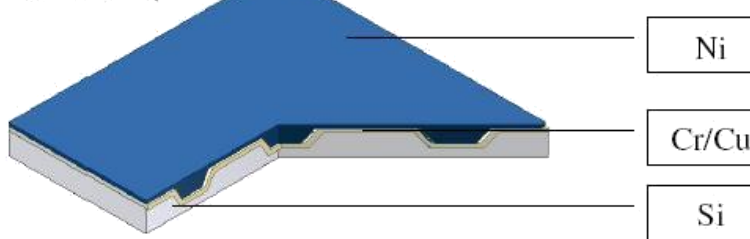

7. 脫模

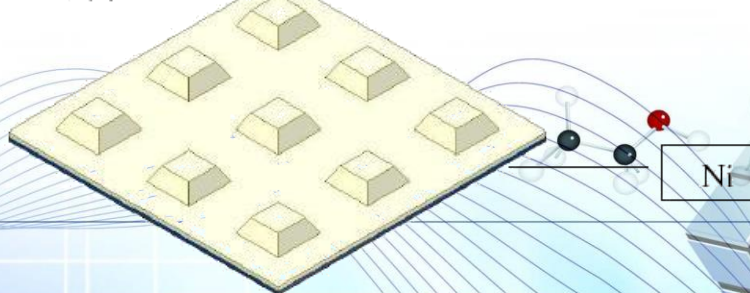

微結構充填不足

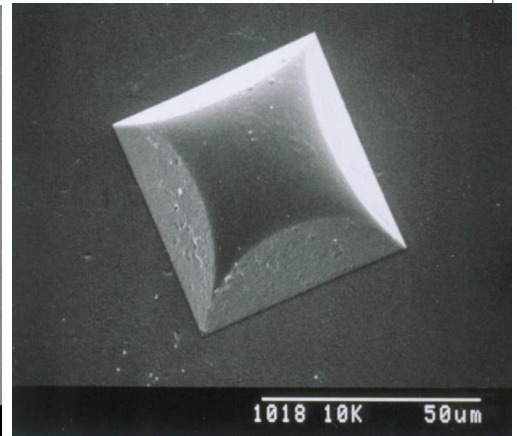
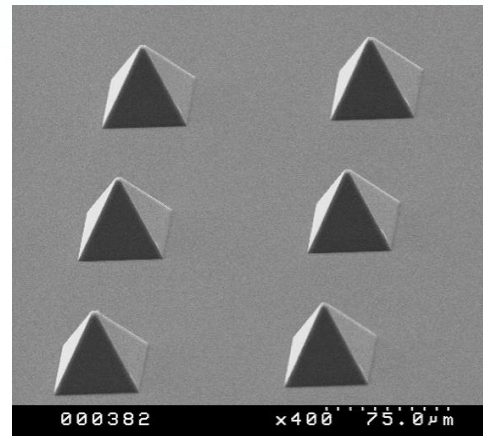
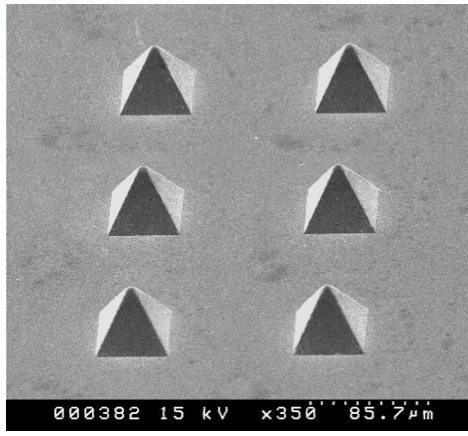
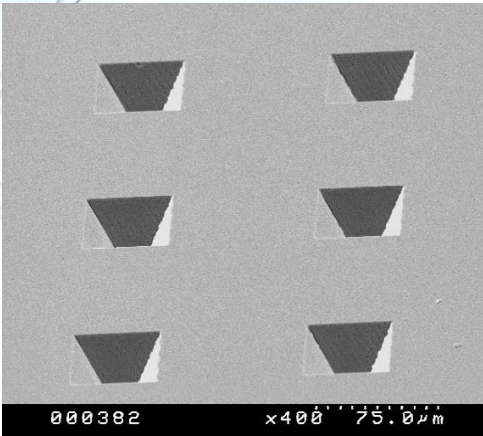

一次電鑄鍍模仁

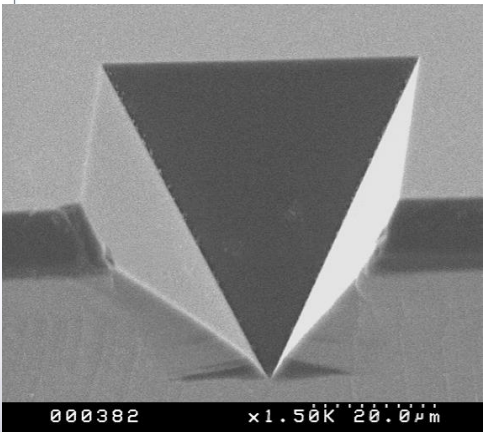

砂模仁

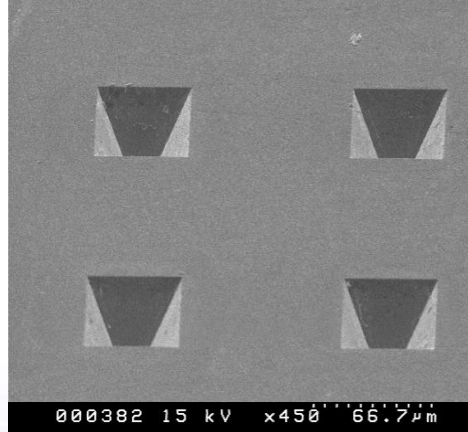

二次電鑄鍍模仁

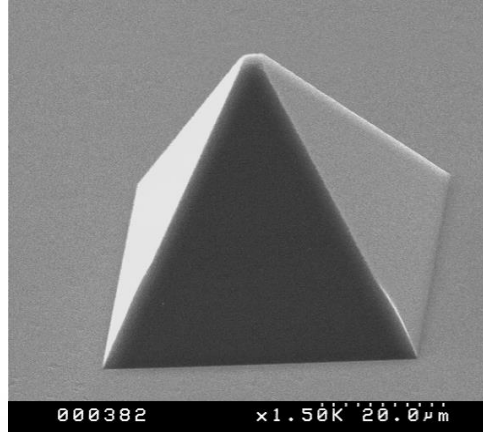

PMMA壓模成形

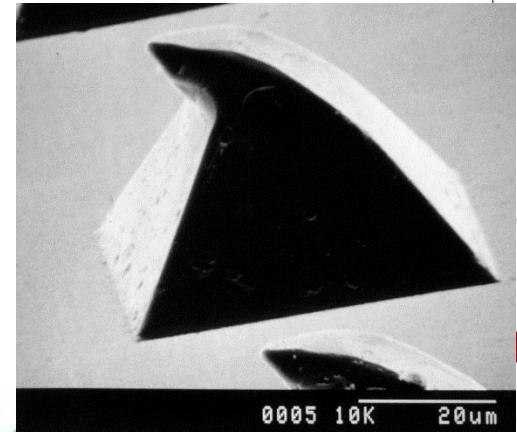

微結構收縮變形

SIGA 製程應用技術 (1)

- 成形方法：
1. Lithography + RIE etching
 2. Photoresist reflow
 3. Direct writing of e-beam or laser
 4. Shaped light beam method
 5. Grey tone mask technique

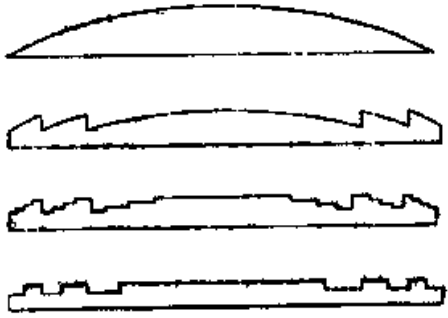

Lenses

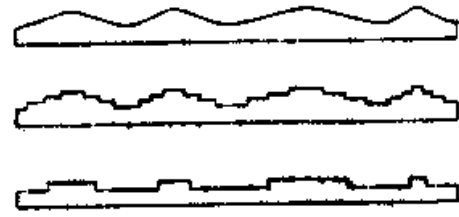

Holograms

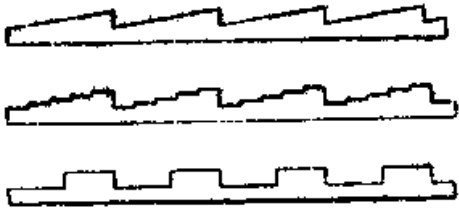

Gratings

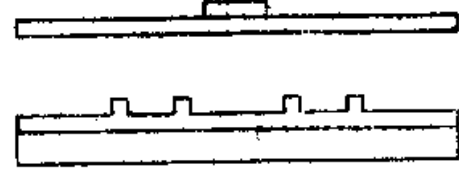

Waveguides

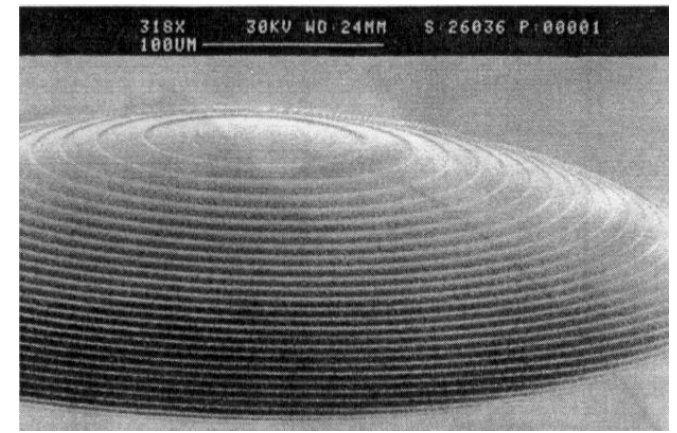
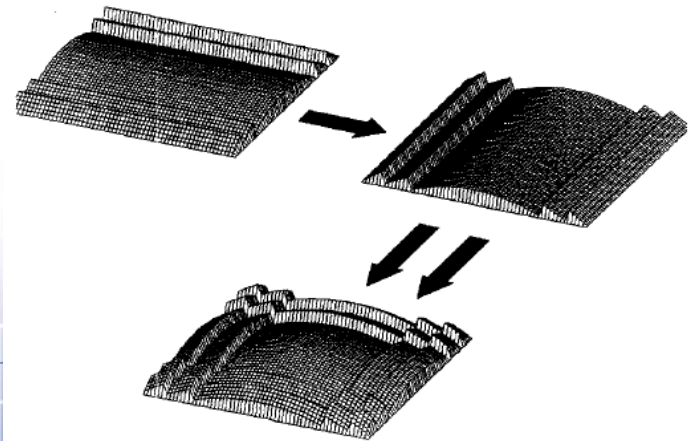

Direct writing of e-beam

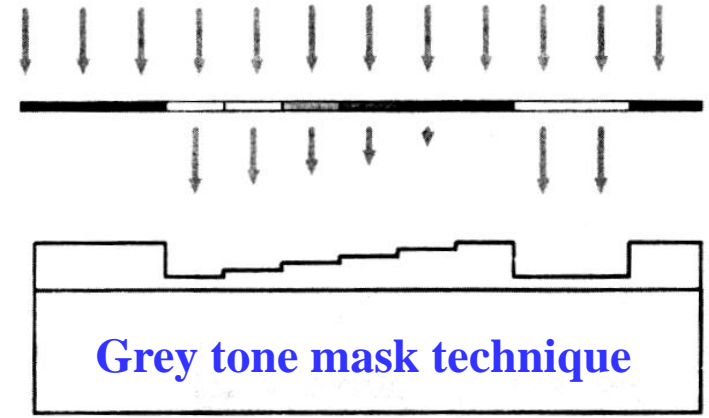

四階全像片應用

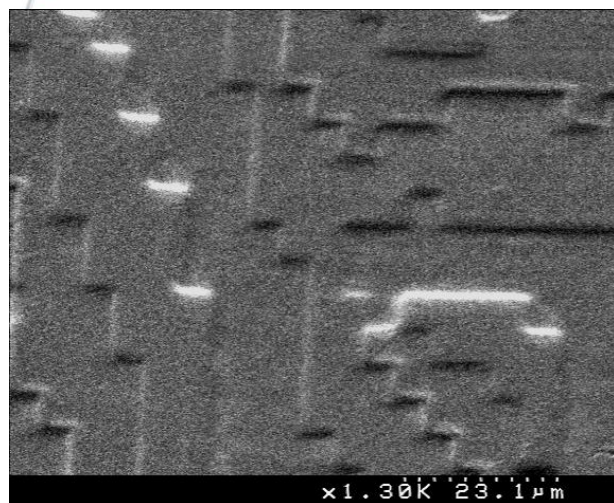

像素 $5\mu m$
四階全像片

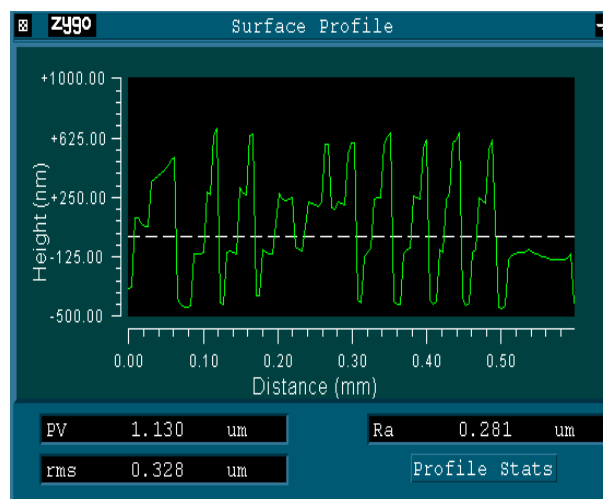

四階全像片 α -
step圖

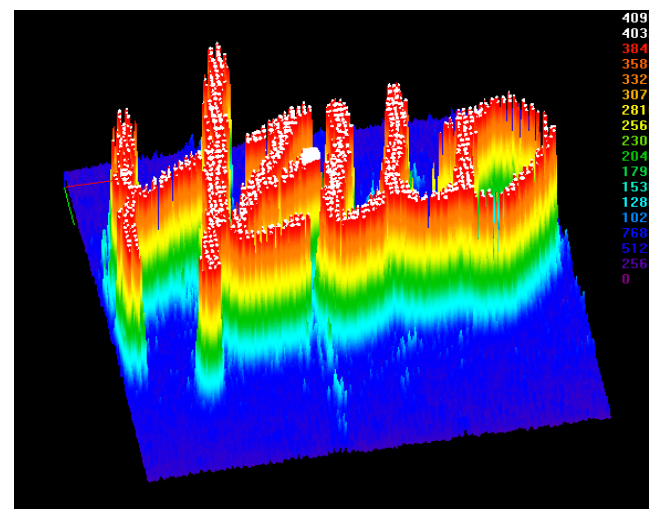

“HELLO”
影像輸出

四階全像片加工技術

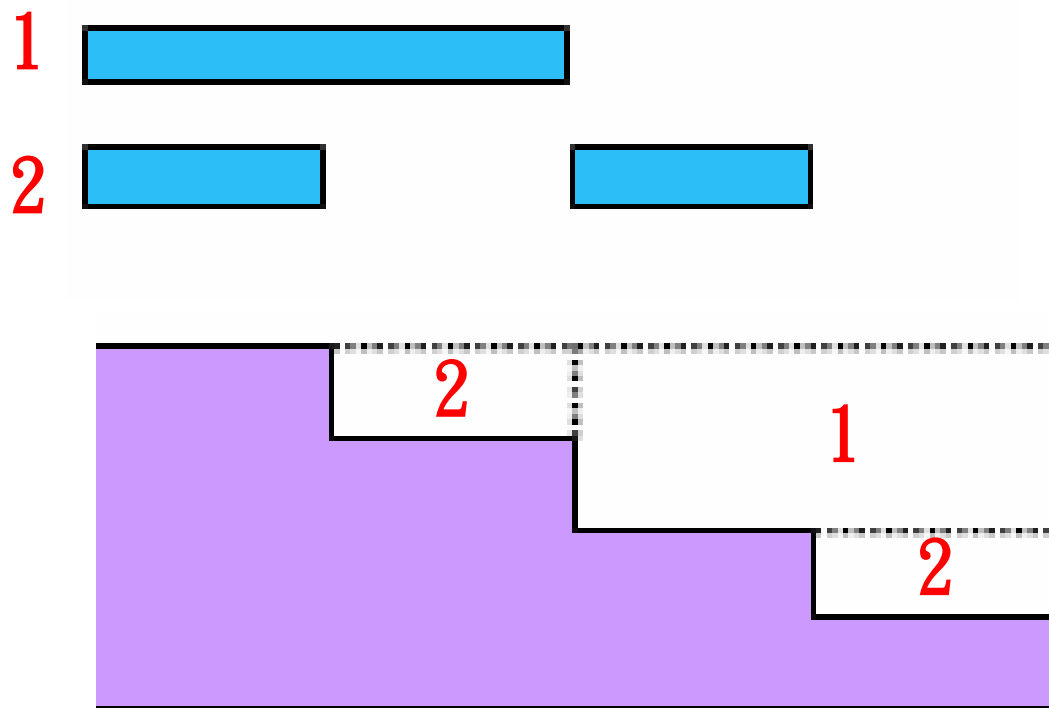

四階光罩組合

全像片模仁製作流程圖



Si

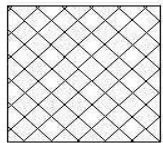

S1813

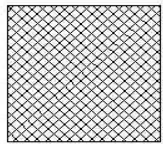

Cr/Ag



Ni



(1) 清洗矽晶片，並烤乾



(2) 光阻塗佈，並軟烤

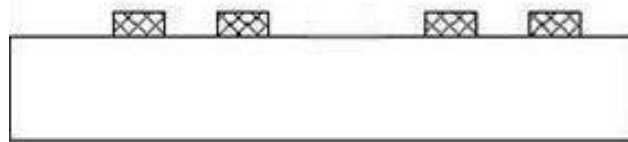

(3) 曝光顯影

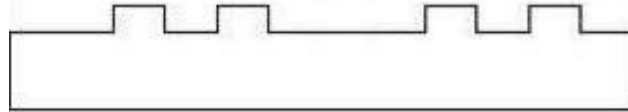

(4) 蝕刻第一層

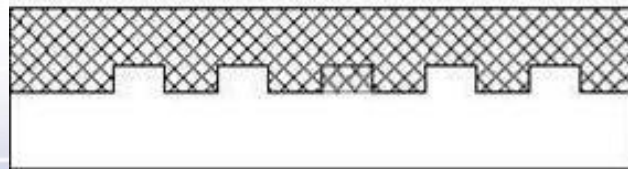

(5) 二次塗佈光阻

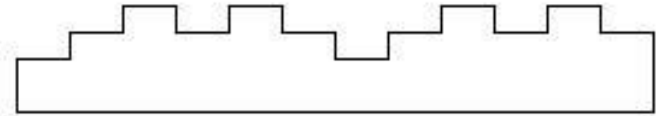

(6) 蝕刻第二層

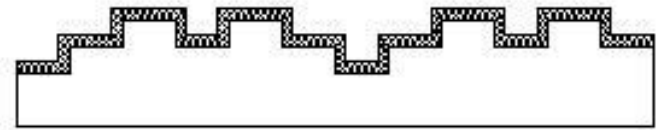

(7) 蒸鍍Cr/Ag

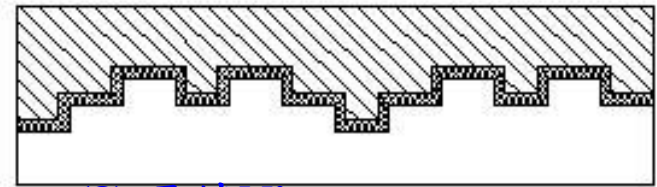

(8) 電鍍Ni

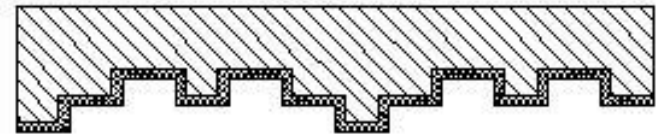

(9) Ni模

微透鏡陣列製程

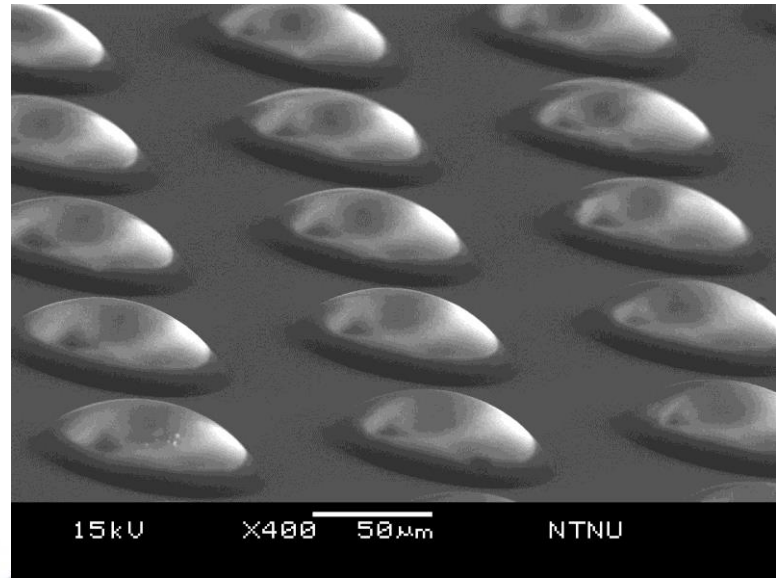
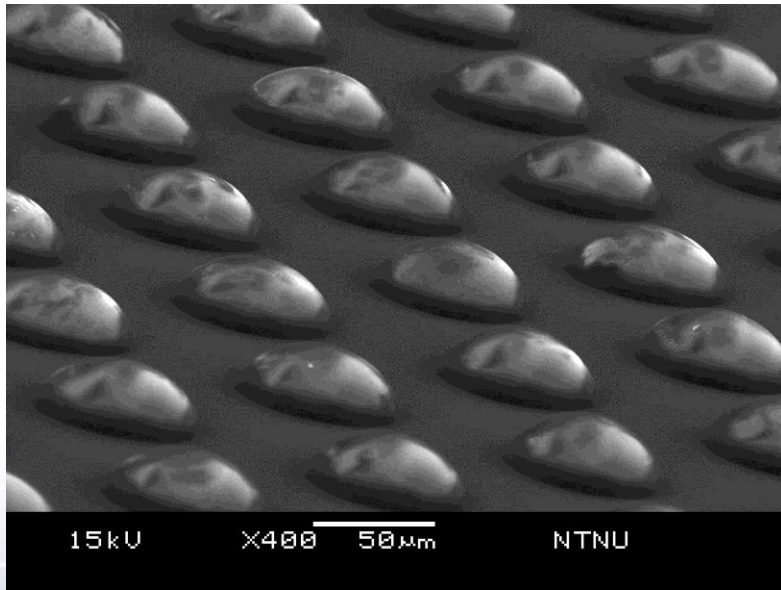
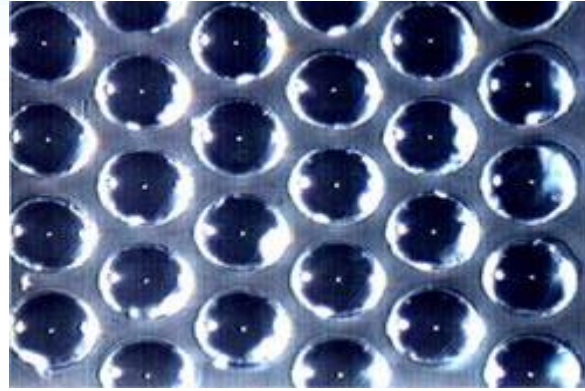

微透鏡陣列

Transferring Photoresist Pattern into Silicon

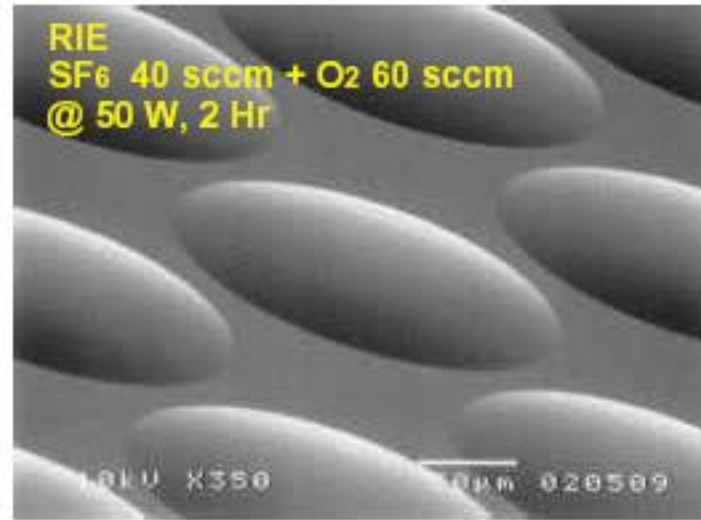
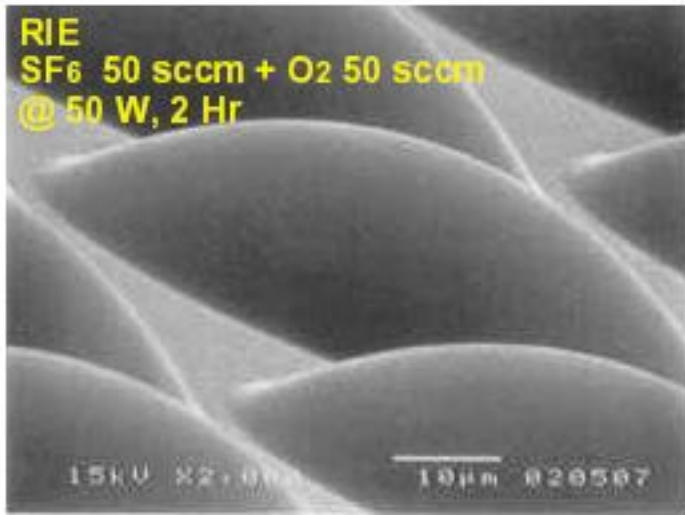
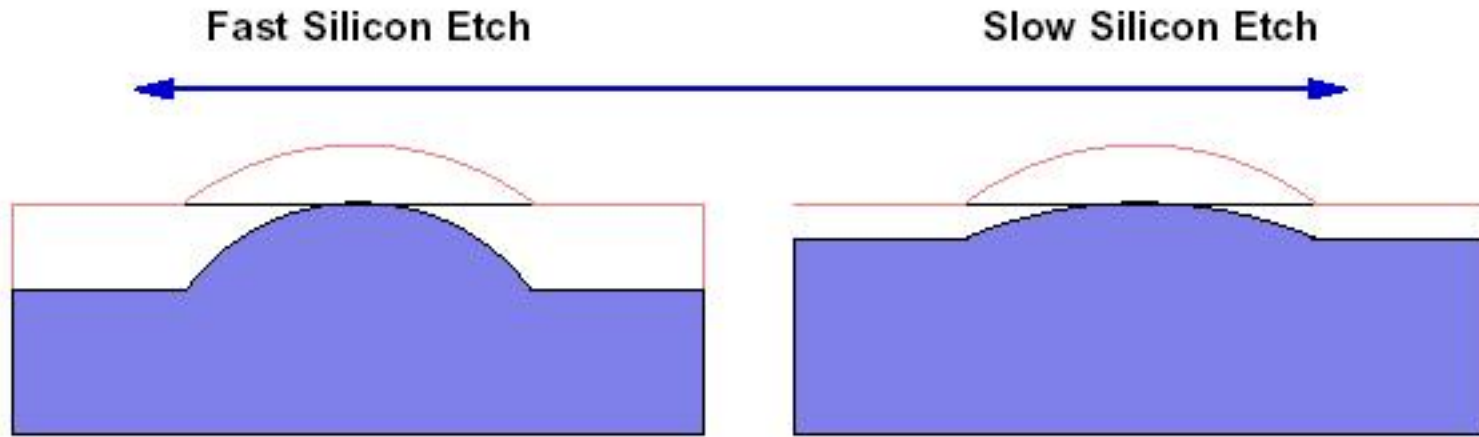

電鑄後的SEM圖

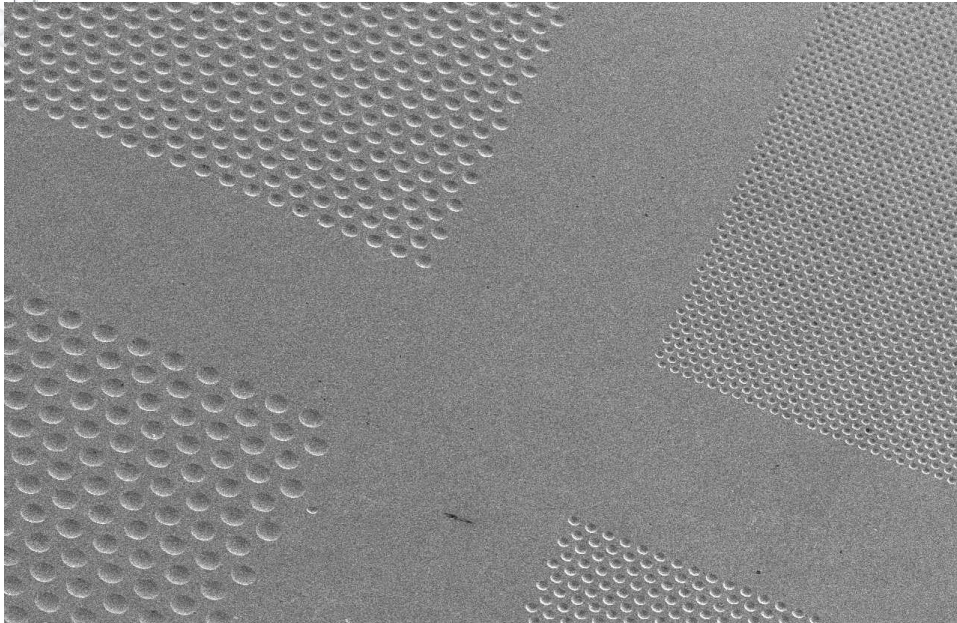

15kV X16 1mm NTNU

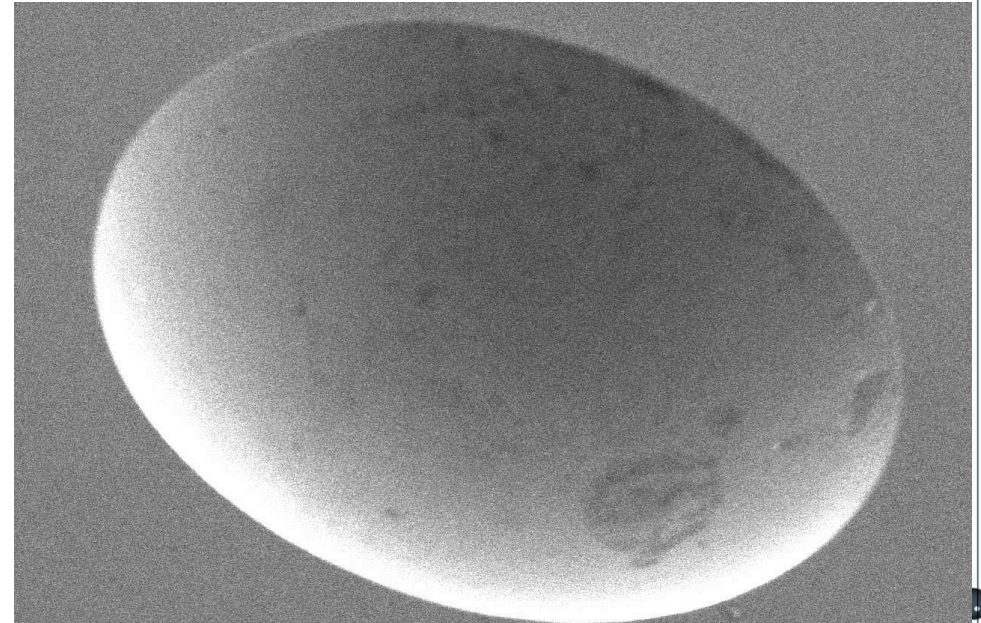

15kV X1,500 10µm NTNU

微透鏡陣列壓模成果

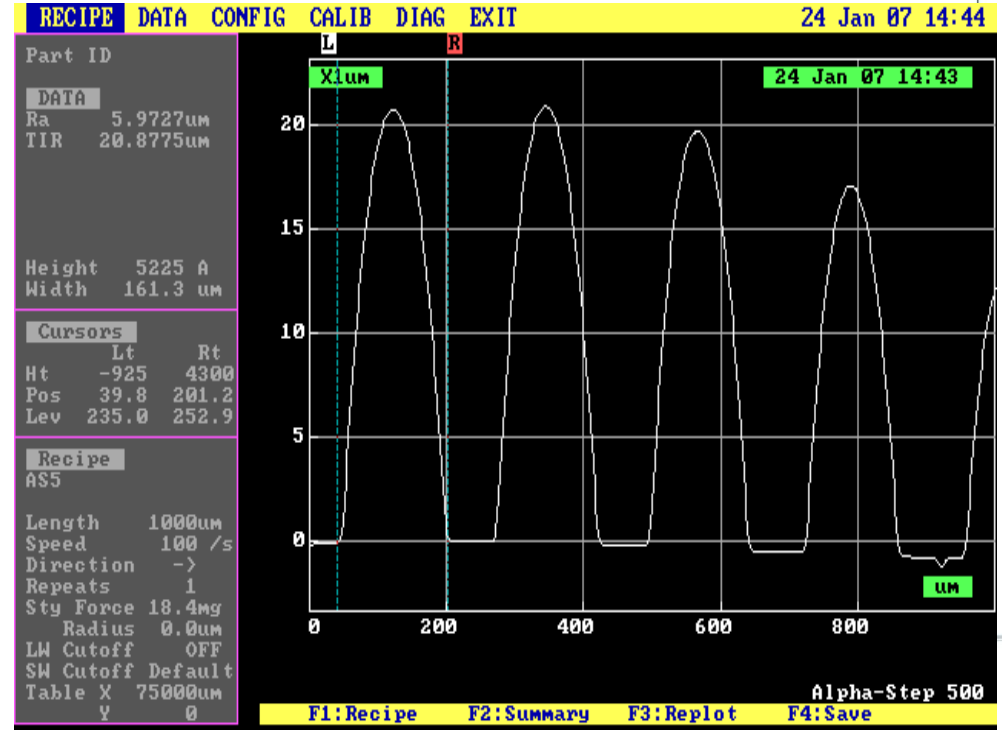
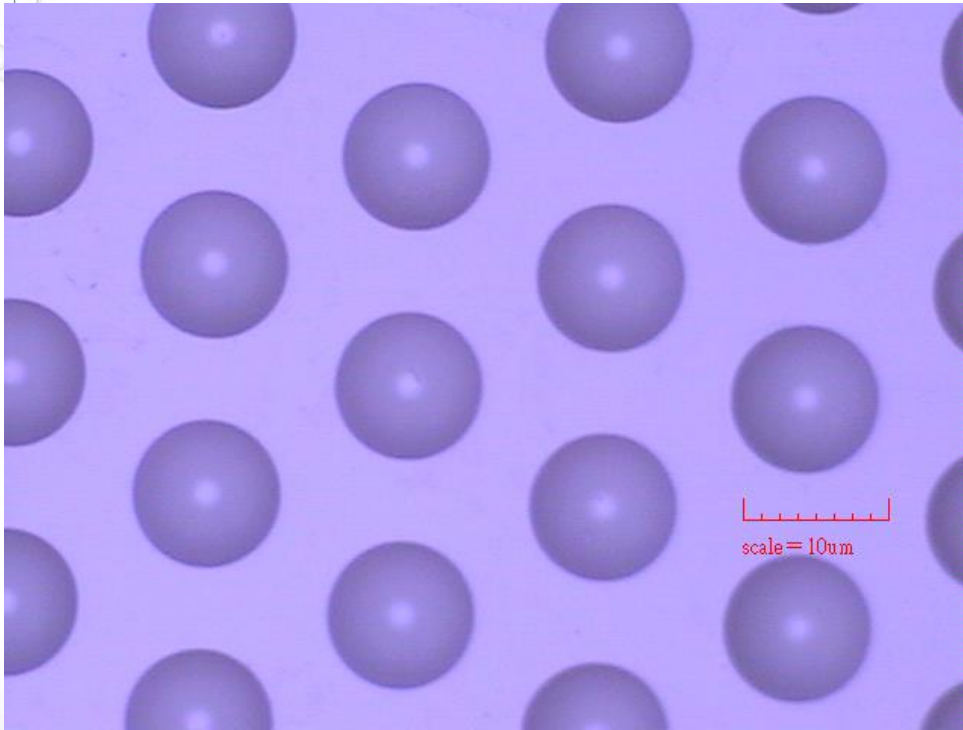

微透鏡模仁製作流程圖



Si

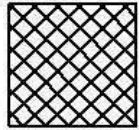

AZ4620

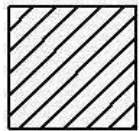

Reflow

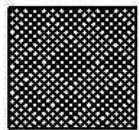

Cr/Ag

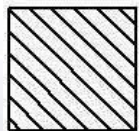

Ni



(1) 清洗矽晶片，並烤乾



(2) 光阻塗佈，並軟烤

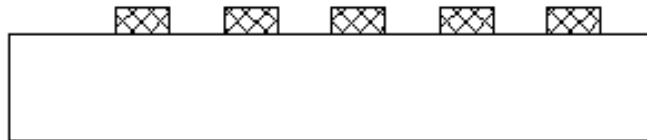

(3) 曝光顯影



(4) 光阻熱熔

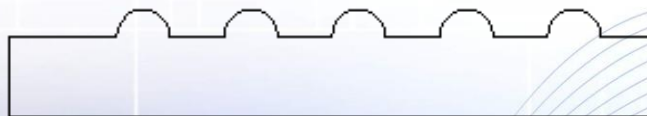

(5) RIE蝕刻



(6) 蒸鍍Cr/Ag

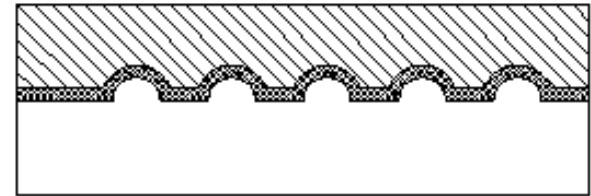

(7) 電鍍Ni

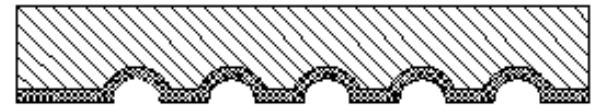

(8) 脫膜

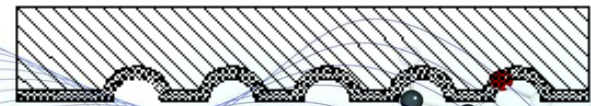

(9) Ni模

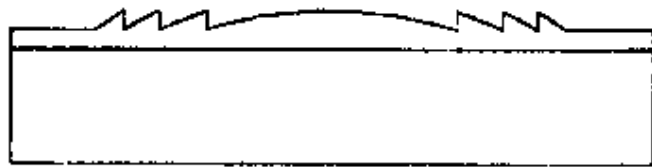

Lens profile in resist on glass or silicon

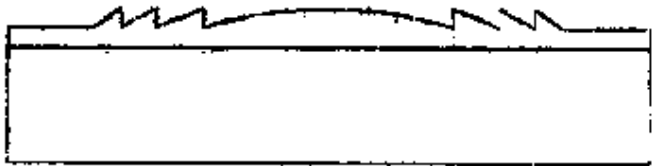
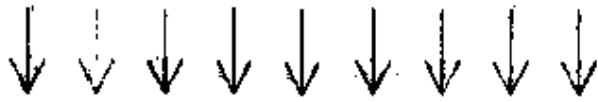

Ion etching



Lens profile etched into glass or silicon

Ni stamper



UV-curable polymer



glass



UV exposure

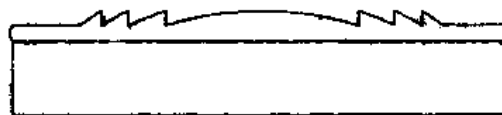

Ni stamper

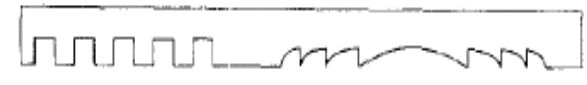

Polymer film

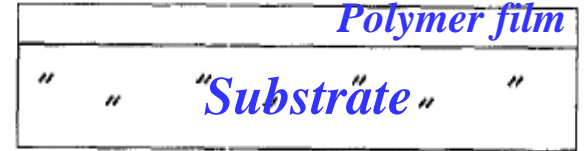

"Substrate"

Replication

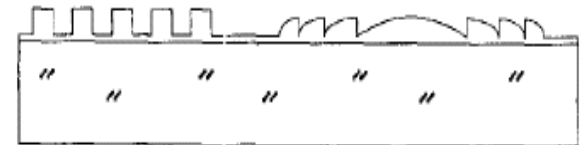

Transfer RIE

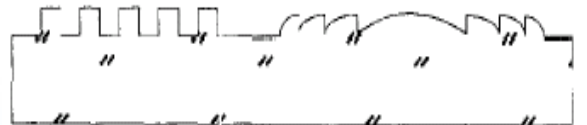

Conclusions

Micro/Nano-Machines

(機械 : "kikai")

create

Macro-Opportunities

(機會 : "kikai")

By Dr. Osamu Tabata, Ritsumeikan University

Keep on moving !

By Dr. Yang, National Taiwan Normal University

The slide features a light blue background with a white grid pattern. In the top-left and bottom-right corners, there are decorative molecular models consisting of black, white, and red spheres connected by lines. The text is centered on the slide.

敬請批評與指教

Thank you for your attention!

Piezoelectric

Direct piezo-action

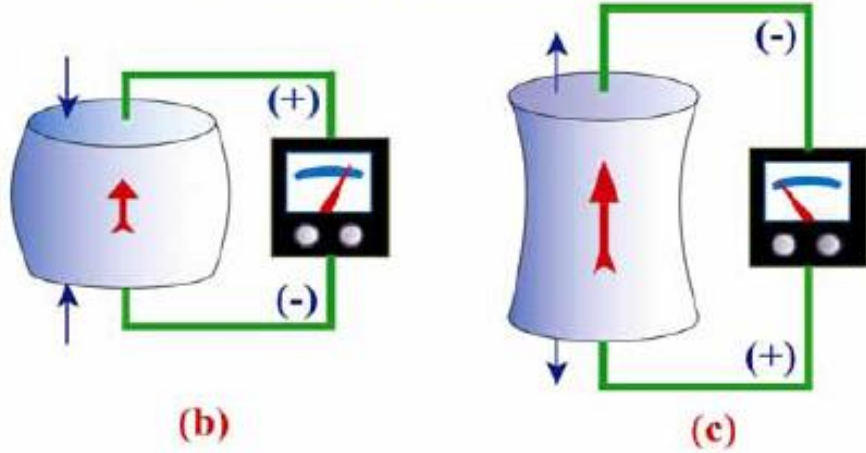

Reverse piezo-action

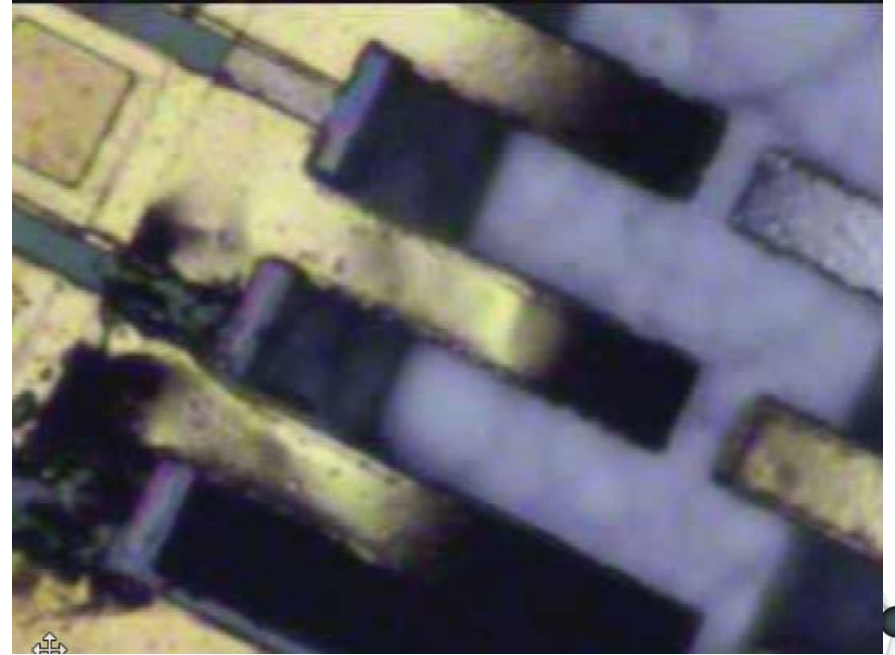
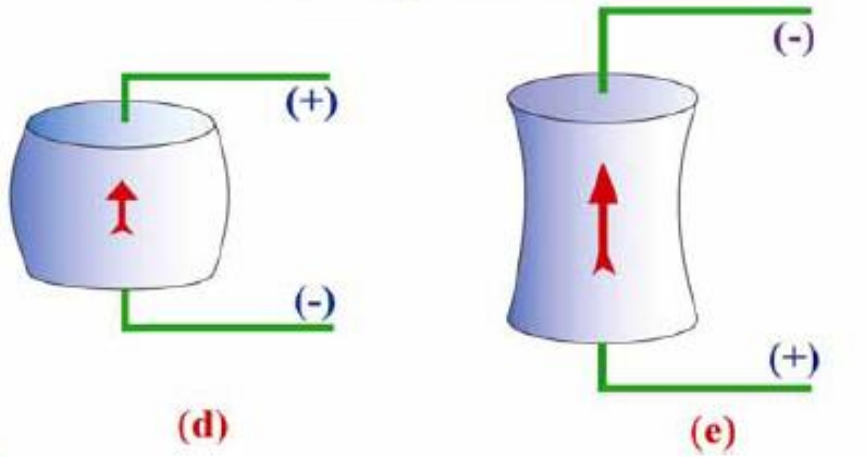

Power Harvesting

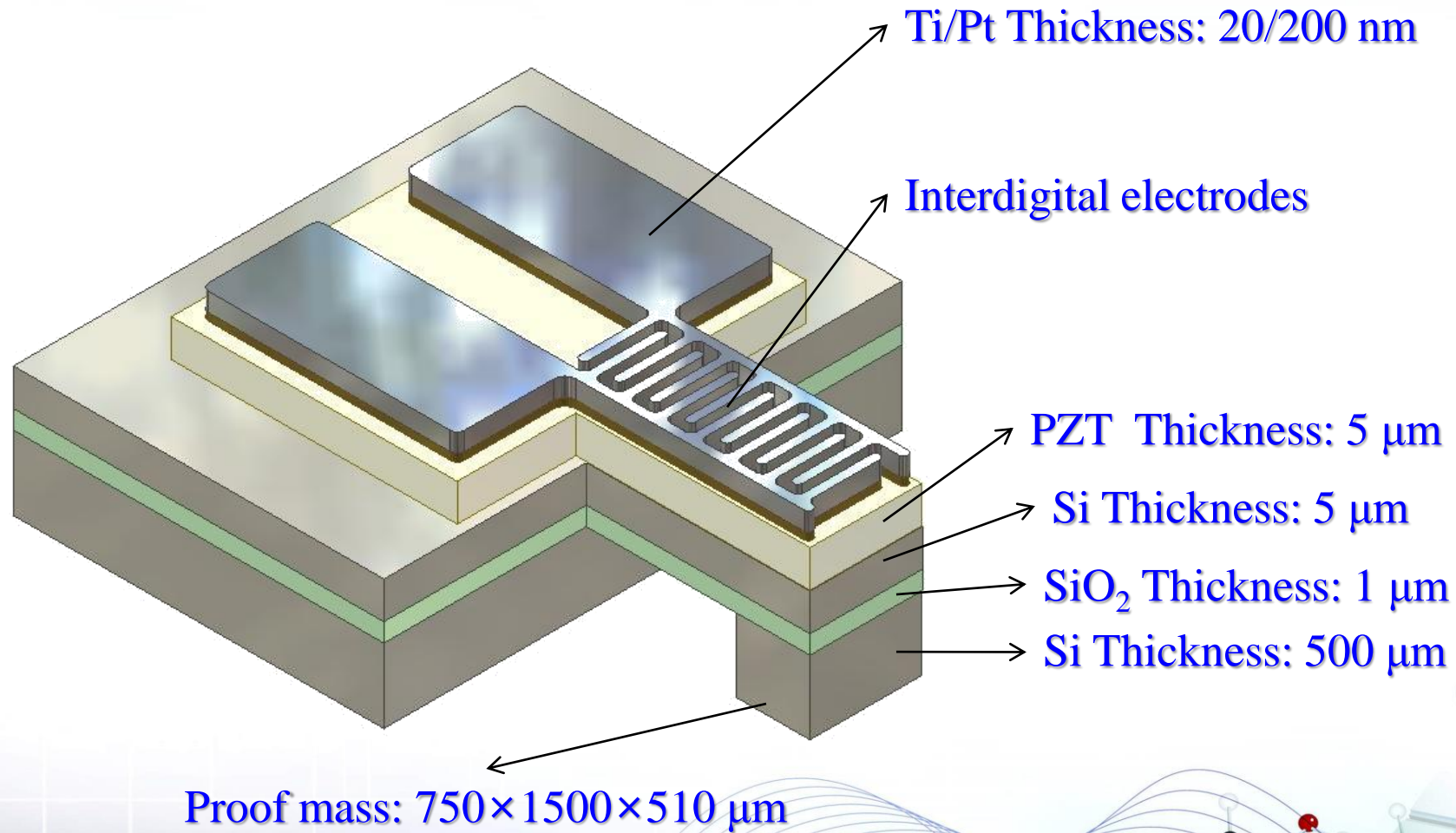

The finished d33 mode piezoelectric MEMS generator.

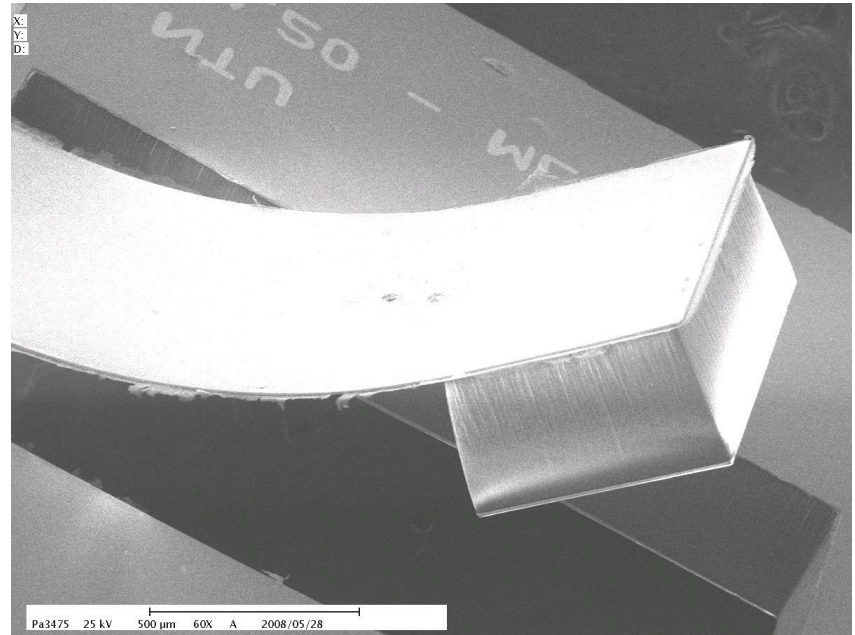
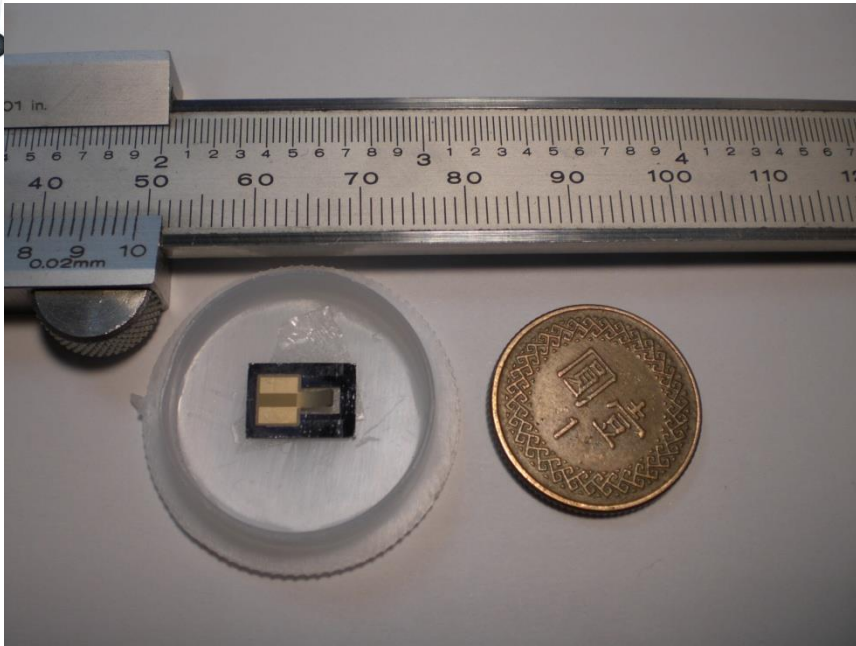

The finished d33 mode piezoelectric MEMS generator.